

General Services Administration
Upholstered Furniture Test Method - FNAE
80-214: A Description of the Method with
Drawings
By
Carl A. Eckelman and Yusuf Z. Erdil

Introduction

In 1977, the Wood Research Laboratory, in the Department of Forestry and Natural Resources of Purdue University, was asked by the General Services Administration of the Federal Government to develop performance tests for upholstered furniture (Eckelman; 1978a, 1978b). These tests were to be used by the General Service Administration in its furniture procurement programs. The resulting standard, FNAE 80-214, has been in use since 1980. Although its purpose was to evaluate the fitness for use of upholstered sofas in specified use environments, the method of test has also proven to be a valuable aid in the engineering design of efficient robust sofa frames constructed of solid wood, as well as well as other materials including plywood and various composites.

It has, for example, been used for such wide-ranging purposes as evaluating new frame designs; evaluating new joint constructions and new fasteners such as metal-toothed connector plates; and evaluating new materials of construction such as softwood plywood, hardwood plywood, laminated veneer lumber, and oriented strand board.

The equipment needed to conduct the tests is relatively inexpensive, simple, foolproof, and easily maintained. It can be constructed from readily available materials without precision machining. Furthermore, the simple-joint systems used allow the load heads to follow the complex motions of the various parts of the furniture and re-index into the proper position at

the end of each load cycle – a degree of freedom of movement that is difficult to obtain with such simple low cost equipment.

Largely as a result of its value as an aid to engineering design and the simplicity of the equipment needed to conduct the tests, there has been a steady demand for information both about the test method and the construction of the equipment needed to carry out the tests. This document was prepared in order to make this information readily available to the furniture industry, and, in particular, to provide detailed drawings of the test equipment.

1.0 Overview of the Test the Method

The upholstered sofa is subjected to a set of loads that is applied to the seat, back, arms, or legs at selected positions at a rate of twenty cycles per minute. The test is continued at this load level until 25,000 cycles have been completed. Loads are then increased by a given load increment and the test continued for another 25,000 cycles. This process is repeated until some part of the sofa suffers disabling damage or a desired level of performance has been achieved. The performance rating of the sofa is taken as the highest load level it was able to successfully complete 25,000 cycles.

2.0 Description of Tests

2.1 Seat Load Test

2.1.1 Summary of Method

The cyclic vertical seat load test for sofas consists of subjecting the seat of the sofa to the “sitting action” of three identical load heads, Figure 1a. These loads are applied at the center and at points 1/6 the length of the open face of the sofa from each end as shown in Figure 1b.

2.1.2 Test Set-Up

The sofa is placed in the testing machine frame as shown in Figure 1a. It is supported by lengths of channel iron that pass beneath the legs and rest on crossbars of the main testing machine frame. One end of each of the channel iron supports is attached to a crossbar with a U-bolt. If the sofa has a center leg, it should also be supported.

In practice, the sofa is first positioned symmetrically beneath the center load head; the load frames on either side are then adjusted so that the load heads contact the seat cushions at the proper points lengthwise of the sofa. Ordinarily, the sofa rather than the load frame is adjusted to obtain the proper front to back position of the sofa.

Vertical positioning of the sofa may be obtained by adjusting the height of the crossbars supporting the channel iron supports. The load heads should just clear the surfaces of the seats when the air cylinders are fully retracted. Overall positioning of the sofa should be such that the underside of the sofa may be readily inspected from below while a test is in progress.

2.1.3 Procedures

Testing of the sofa is begun with 100 pounds applied to the rear load position of the load head and with 50 pounds applied to the front position. The dead weight of the load frame and load head at the front and rear points is added to that of the load applied by the air cylinders at the same points to obtain the loads applied to the sofa. Rear loadings are increased in increments of 25 pounds and front loadings in increments of 12.5 pounds after 25,000 cycles have been completed at each preceding load level. Once a load level of 250 pounds has been reached at the rear position along with a corresponding load level of 125 pounds at the front, the loads are held constant, and the test is continued at this maximum load level. The sofa is carefully re-examined for damage each time an additional 25,000 cycles has been completed.

Tests are continued until some type of seat foundation failure such as breakage of a spring occurs, until some type of frame failure occurs, or until a desired level of performance has been achieved.

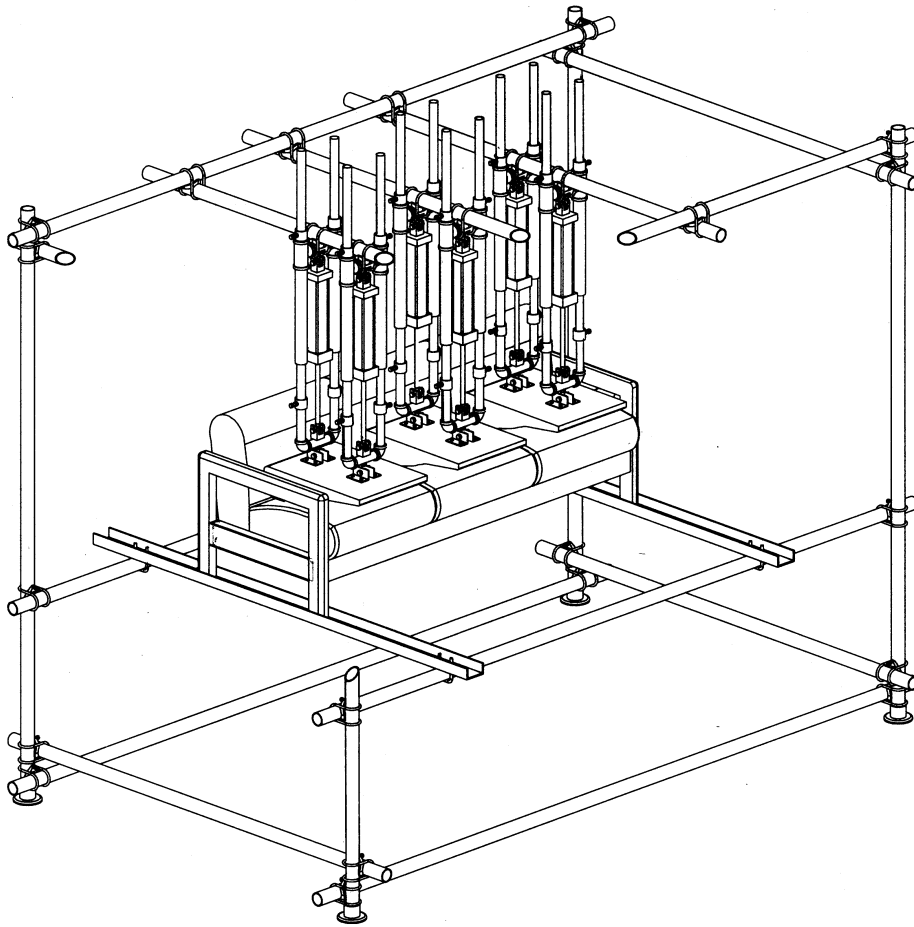

Figure 1a. Seat load test setup.

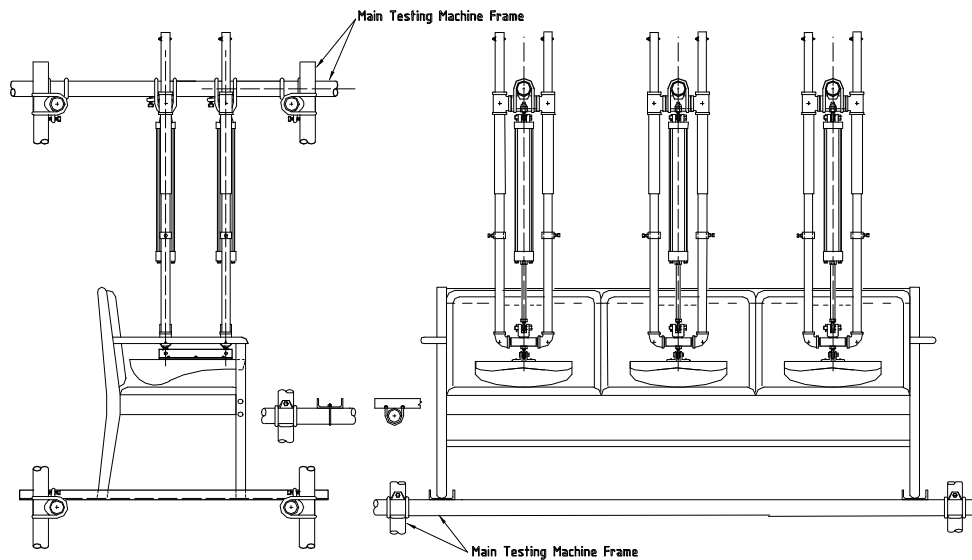

Figure 1b. Loads are applied at the center and at points 1/6 the length of the open face of the sofa from each end. Ordinarily, these points correspond to the centers of the seat positions.

2.2 Backrest Foundation and Backrest Frame Test

2.2.1 Summary of Method

The test consists of applying three loads to the backrest of the sofa in a front to back direction, Figure 2a. These loads are applied at the center and at points 1/6 the length of the open face of the sofa from each end. In the case of the *backrest foundation tests*, point of contact of the center of the load heads with the backrest surface is 9 inches above the point of intersection of the backrest with the seat surface. The line of action of the load frame is inclined downward at an angle of 12.5 degrees with the horizontal, Figure 2b.

For the *backrest frame tests*, the center of the load head is positioned 16 inches above the point of intersection of the surface of the backrest with the surface of the seat. This provision is subject to the constraint that the load may not be applied at a point higher than one inch below the top surface of the top rail. Angle of inclination of the load frame for this test is zero degrees, Figure 3b.

2.2.2 Test Setup

The sofa is placed in the testing machine frame as shown in Figure 2a for the *backrest foundation test* and as shown in Figure 3a for the *backrest frame test*. A length of 3/4-inch diameter pipe is placed crossways behind the rear legs of the sofa, Figures 2a and 3a, to keep the sofa from sliding backwards. This pipe in turn is held in place by short lengths of 2-inch diameter pipes that are attached to members of the testing machine frame itself by means of scaffolding clamps. Pipe hold-downs, Figures 2c and 3a, are used to keep the sofa from overturning as the loads are applied to the backrest. These hold-downs are attached as shown in the above-mentioned

figures. If the legs of the sofa have a tendency to jump over the pipe stop, hold-downs may also be applied to the tops of the arms near the rear of the sofa. It is important that these hold-downs do not restrain the sofa in the front to back direction as it is loaded during the back test, i.e., the hold-downs should be adjusted so that the front end of the sofa does not lift off the floor, but the sofa should still be able to slide freely beneath them.

Overall height of the entire load frame assembly is adjusted by raising

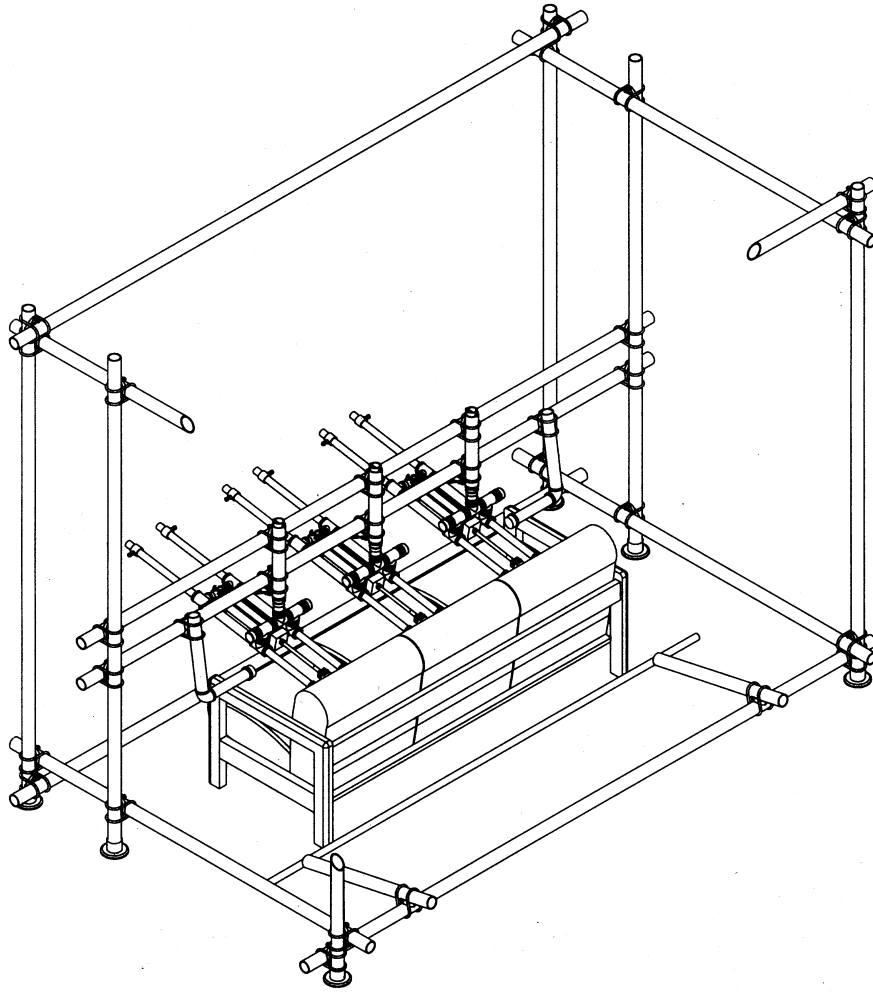

Figure 2a. Backrest foundation test setup.

or lowering the 2-inch diameter swivel column sleeve bearing that attaches the swivel column to the main testing machine frame. Alternatively, the entire backrest load assembly may be raised or lowered by means of “ratchet cable pullers.” These cable pullers are attached to the tops of the two columns supporting the horizontal pipes to which the load frames are attached. The other ends of the cable pullers are attached to the opposite ends of the top horizontal pipe to which the load frames are attached. Lengthwise adjustment of the frames with respect to the back position is

also effected by adjusting the swivel column sleeve. Front to back adjustment of the sofa with respect to the load heads is accomplished by adjusting the position of the pipe leg stop that passes crossways behind the back legs of the sofa. Ordinarily, the sofa should be positioned so that there is a slight amount of clearance between the backrests and the load heads when the air cylinders are fully retracted.

2.2.3 Procedures

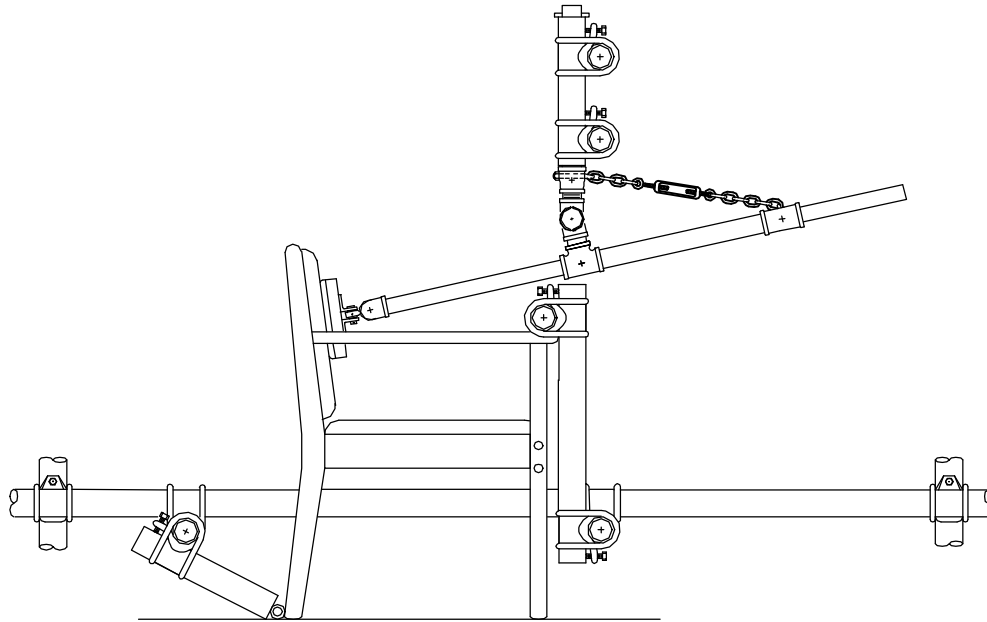

Figure 2b. Details of setup for backrest foundation test showing line of action of the load frame.

2.2.3.1 Procedures—Backrest Foundation Test

The test is begun at the 50-pound load level. Loads are increased in increments of 12.5 pounds after 25,000 cycles have been completed at each previous load level. Testing is continued until some type of physical failure occurs in the backrest foundation system such as a broken spring or until a desired level of performance has been achieved.

2.2.3.2 Procedures—Backrest Frame Test

The test is begun at the 75-pound load level. Loads are increased in increments of 25 pounds after 25,000 cycles have been completed at each preceding load level. Testing is continued until the frame suffers disabling damage or until a desired level of performance has been achieved.

To carry out this test, an L-shaped pipe frame constructed of a 6-inch length and a 36-inch length of 1-1/4-inch diameter pipe coupled together with an elbow is attached to one leg of the external backrest load frame by means of a scaffolding clamp, Figure 3b. The long leg of the L-shaped frame rests on the top rail of the backrest of the sofa. Its purpose is to maintain the load frame at the proper elevation for testing of the backrest

frame. Specifically, the support leg of the frame should be adjusted so that the center of the load head is 16 inches above the point of intersection of the surface of the backrest with the surface of the seat or one inch below the top surface of the top rail, whichever is lower.

In the event that the backrest frame is damaged during the backrest foundation tests, it will be necessary to use a new sofa for this test. It is also permissible to use a new sofa in the backrest frame test regardless of whether or not observable damage has occurred during the backrest foundation test. Also, if a leg should break before the backrest tests are completed, a substitute leg may be clamped to the sofa frame and testing continued.

In the event that the backrest frame is not damaged during the backrest

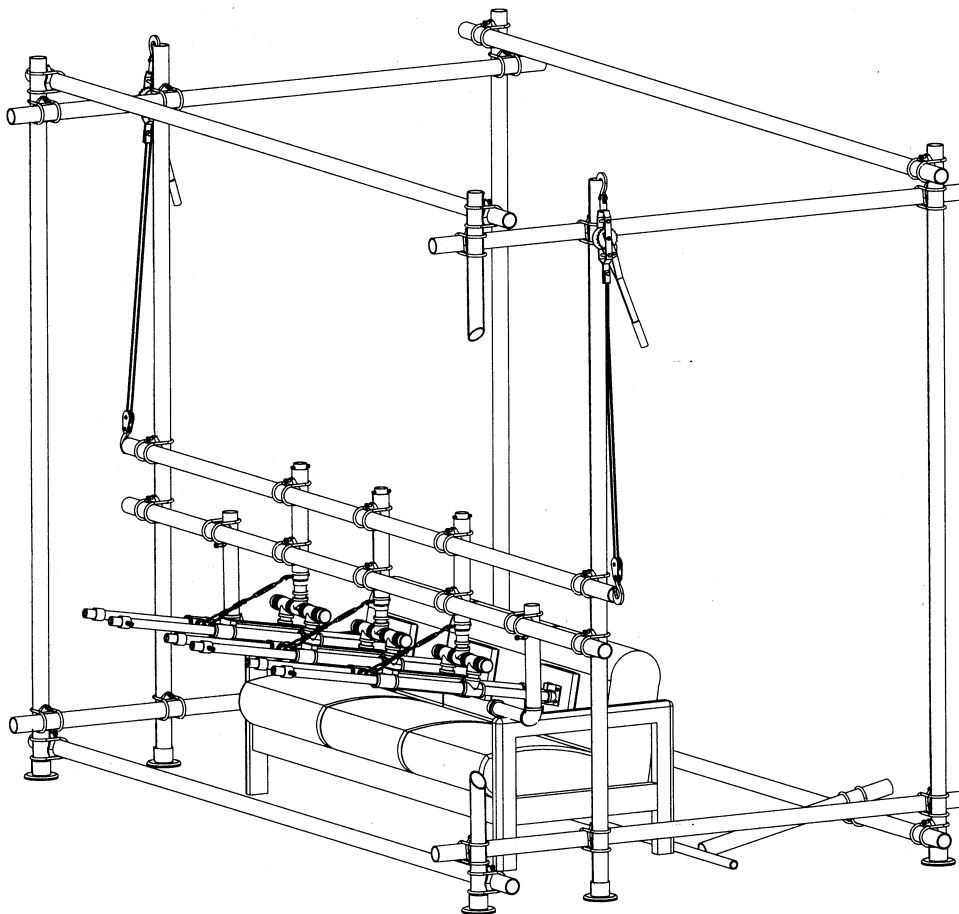

Figure 2c. Alternate view of backrest foundation test setup showing pipe hold downs used to prevent sofa from overturning backward.

foundation tests, a portion of the load cycles completed during that test may be applied to the backrest frame test. Specifically, testing may be started in the backrest frame test (on the same sofa used in the backrest foundation test) at the nearest backrest frame load level below the last load level achieved in the backrest foundation test.

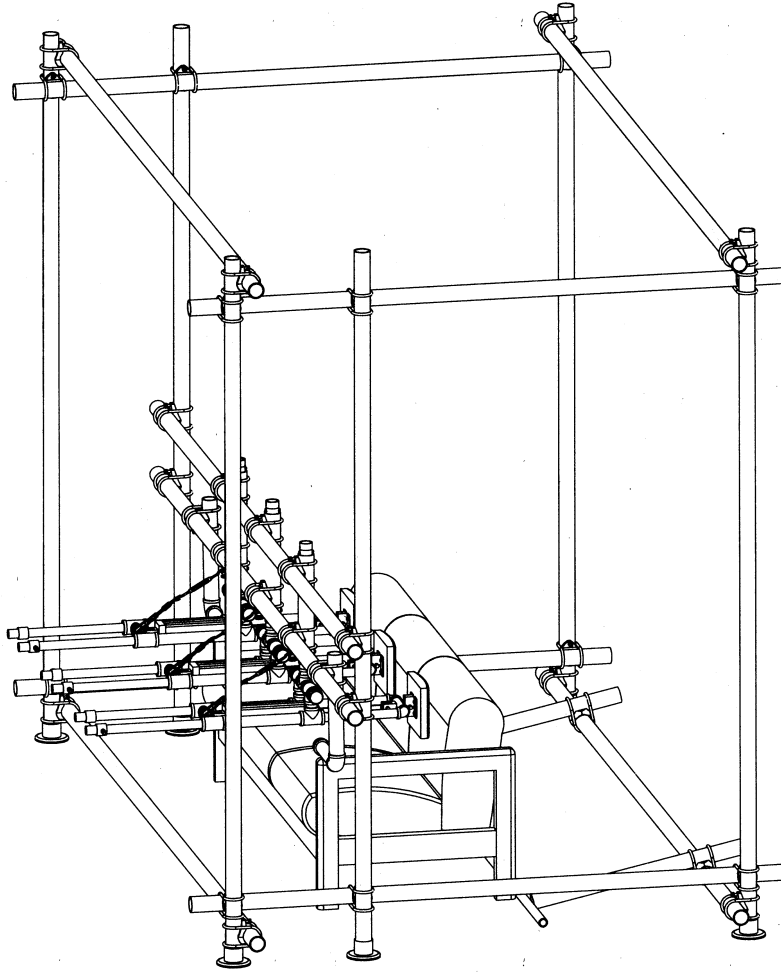

Figure 3a. Overall view of test setup for backrest frame test.

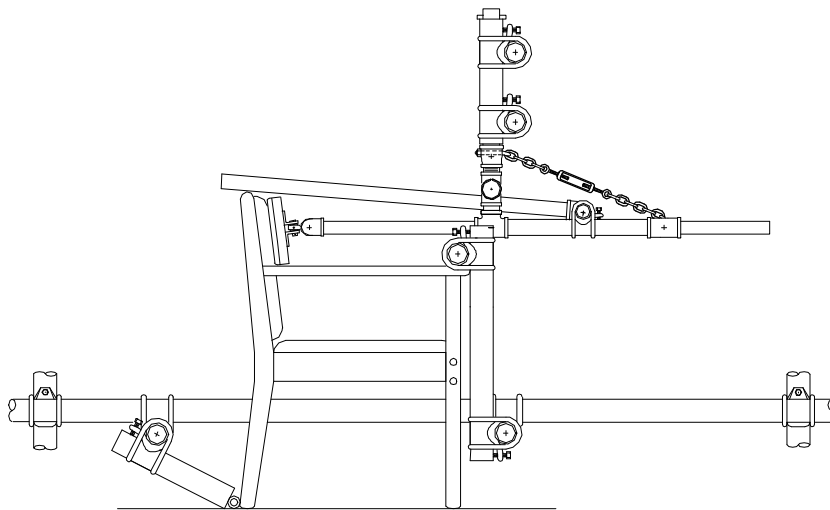

Figure 3b. Details of setup for back frame test. Note the additional pipe attached to the frame that is used maintain the load frame in the proper position relative to the top rail

2.3 Horizontal Sidethrust Arm Load Test

2.3.1 Summary of the Method

subjecting one arm of the sofa to a horizontal force in an outward direction possible to the point of intersection of the stump with the arm.

The setup is shown in Figure 4. A 3/4-inch diameter pipe main testing machine frame, is butted up against the legs at the end of the sofa being tested. This crossbar prevents the sofa from sliding when loads are applied to the arm. Lengths of pipe (see Figure 4) that are attached to the main testing machine frame are used to provide a 1/2-inch diameter pipe leg stop. In the event of an offset with respect to the front leg, it may be necessary to use an individual leg stop for each leg. Hold downs may be needed to prevent the legs from jumping over the leg stop. Hold downs also may be used at the other end of the sofa.

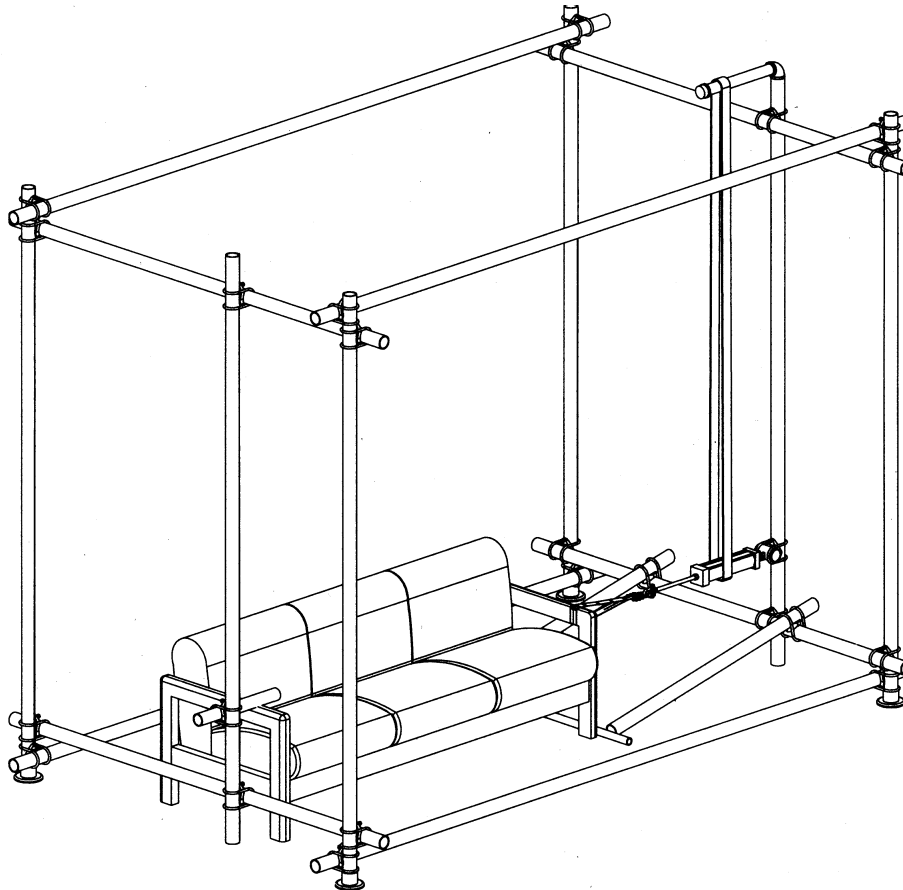

Figure 4. Set-up for side load test on arms.

Sidethrust forces may be applied to an arm by means of a strap and air cylinder as shown in Figure 4. The cylinder should be adjusted in height so that the centerline of the force passes through a point as near as possible to the intersection of the longitudinal axis of the arm with the longitudinal axis of the stump. Loads are applied in one direction only in this test so that the cylinder is not retracted during the off cycle.

2.3.3 Procedures

A single load is applied to the arm at a point that corresponds as closely as possible to the intersection of the longitudinal axis of the arm with the longitudinal axis of the stump, Figure 4. The legs at the end of the sofa being loaded are blocked with a 3/4-inch diameter pipe.

Tests are started at the 50-pound load level; loads are increased in increments of 25 pounds after 25,000 cycles have been completed at each preceding load level. The test is continued until the arm suffers disabling damage or until a desired level of performance is reached. If a leg should break during the test, a substitute leg may be clamped to the sofa frame and the test continued.

2.4 Sidethrust Load Test on Legs

2.4.1 Summary of the Method

The method consists of applying a sidethrust load to a sofa in such a way that the legs at one end of the sofa are loaded in an inward direction, Figure 5. The load should be applied in a direction parallel to the floor and perpendicular to the longitudinal axis of the side rail at a point on the side rail midway between the front and back legs. The sofa is prevented from sliding endways by means of a pipe stop that butts up against the legs at the end of the sofa under test. This pipe stop applies floor reaction forces to the legs in an inward direction so that the desired loading of the legs is achieved.

2.4.2 Test Set-up

The sofa is placed in the testing machine as shown in Figure 5. A 3/4-inch diameter crossbar is butted up against the legs at the end of the sofa being tested. This crossbar acts as a backstop that prevents the sofa from sliding when loads are applied to the end of the sofa and also applies sidethrust forces to the legs. Pipes, which run parallel to the length of the sofa, may be placed immediately in front of and behind the sofa at a height of a few inches above the floor. These pipes prevent the sofa from slipping out of line during the course of the test yet allow it to slide freely endways. Lengths of pipe (see Figure 5) that are attached to the main testing machine frame are used to provide a backstop for the 3/4-inch diameter pipe leg stop. In the event the rear leg is offset with respect to the front leg, it may be necessary to use an individual leg stop for each leg. Hold-downs may be used as shown in Figure 5 to prevent the free end of the sofa from lifting off the floor. If the legs under test tend to jump over the leg stop, a hold-down of the type shown in Figure 6 may be used to prevent this action.

Sidethrust forces may be applied to the frame by means of an air cylinder as shown in Figure 5. The cylinder and strap should be adjusted

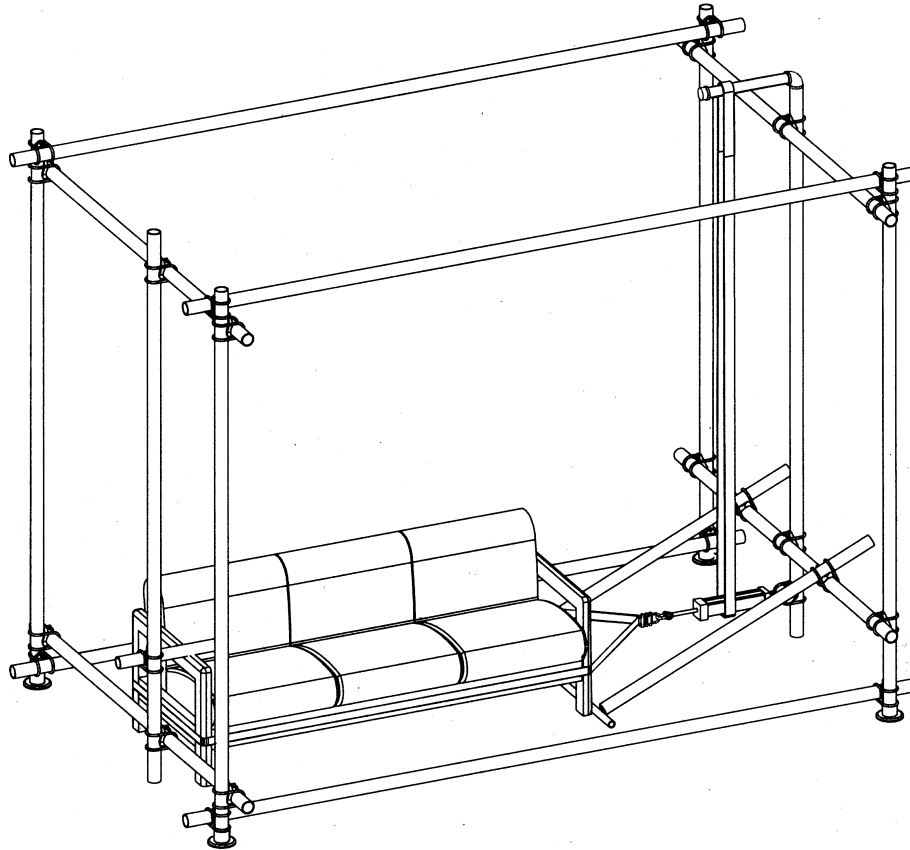

-up for sidethrust load test on legs.

so that the load is applied at a point that corresponds approximately to one shared equally by the front and back legs on the end of the sofa under test.

2.4.3 Procedures

sofa at a point that corresponds approximately to a position midway

with a 3/4-inch pipe in an inward direction.

100-pound load level. Loads are increased in

previous load level. Testing is continued until a leg or the frame suffers disabling damage or until a desired level of performance has been

This test may be carried out on a sofa that has been used in previous tests, or it may be carried out on a new sofa.

2.5 Front to Back Load Test for Legs

2.5.1 Summary of the Method

The test consists of applying a load to each end of a sofa, Figure 6, in such a way that the corresponding rear leg is loaded in a front to back direction. Line of action of the loads is parallel to the floor and perpendicular to the longitudinal axis of the front rail.

The action of these forces is resisted by a bar that is placed crossways behind the rear legs of the sofa. This bar prevents the sofa from sliding backwards when front to back forces are applied to the sofa. It simultaneously applies the desired floor reaction force to the legs.

2.5.2 Test Set-up

The sofa is placed on the floor within the testing machine frame as shown in Figure 6. A length of a 3/4-inch diameter pipe is placed crossways behind the rear legs of the sofa as shown to keep the sofa from sliding backwards. A 3/4-inch diameter is used to ensure that the reaction force is applied to the legs at points 1/2 inch above the floor. This pipe in

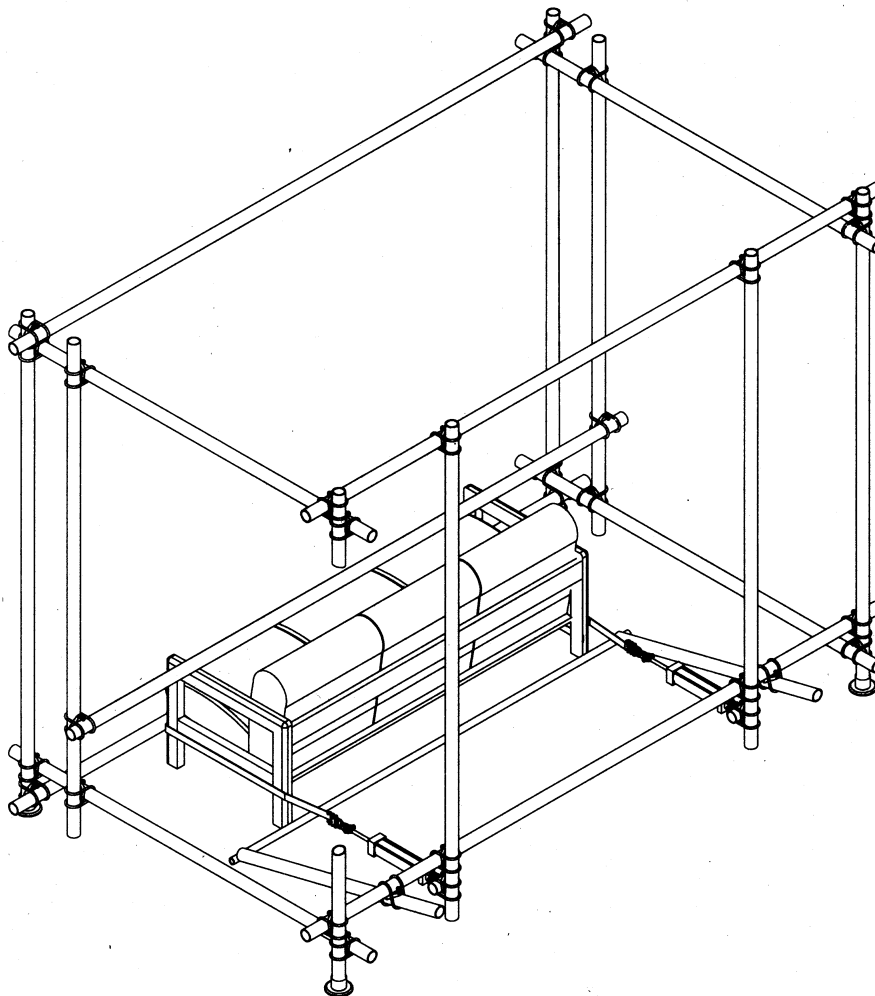

Figure 6. Set up for front to back load test on legs.

turn is held in place by means of lengths of 2-
attached to members of the testing machine frame itself by means of
scaffolding clamps as shown in Figure 6. A single pipe hold down may be
used to keep the sofa from overturning as shown, or hold downs similar to
those shown in Figure 2c may be used. If
tendency to jump over the pipe stop, additional hold-
to the tops of the arms near the rear of the sofa. It is important that these
hold downs do not restrain the sofa in the front to back direction as it is
-downs should be adjusted so that the

the crossbar backstop, but the sofa should still be able to slide freely beneath
the hold downs.

linder and strap may be used to apply loads to the frame, Figure 6.
A method of securing the ends of the strap is shown in Figure 18.

2.5.3 Procedures

-pound load level per cylinder. Loads are
ds per cylinder, after 25,000 cycles have
been completed at each preceding load level. Testing is continued until the
so that load is applied parallel to the floor in a front to back direction,

2.6 Acceptance Levels

Acceptance levels for all of the tests are summarized in Table 1. Initial
load levels and load increments to be used are given in Table 2.

3.0 Specific Test Equipment

3.1 Apparatus for Seat Load Test

An exploded view of the construction of a typical load frame used in
seat position since the use of two frames permits the independent movement
is attached 2 inches from the front edge of the head and the second 11-
inches further to the rear. The load heads are pivoted so that they are free
load head sinks into the seat and simultaneously deflects to the rear. The
load heads are attached to the load frames by means of rod end-
that the heads themselves are able to rotate or tilt sideways as well as in a
spacing between the angle iron brackets that form the “clevises” to which
the rod ends are attached.

nsists of two basic units -
external load frame, Figure 7a. The internal frame consists of two vertical
extension shafts that are joined together at one end by two elbows and a
-shaped frame.

Table 1. Summary of performance acceptance levels.

	Light-service	Medium-Service	Heavy-Service
	Acceptance Level	Acceptance Level	Acceptance Level
	Per Cylinder	Per Cylinder	Per Cylinder
Test	(Pounds)	(Pounds)	(Pounds)
Seat Load Foundation	200+100	250+125	275+137.5
Backrest Foundation	112.5	125	150
Backrest Frame	75	100	150
Front to Back Load on Back Leg	150	200	300
Side Load on Arms	75	150	200
Side Load on Legs	200	250	350

Table 2. Summary of initial load levels and load increments.

	Initial Load	Load Increments	
	Per Cylinder	Per Cylinder	Number of
Test	(Pounds)	(Pounds)	Cylinders
Seat Load Foundation	100/50	25/12.5	3
Backrest Foundation	50	12.5	3
Backrest Frame	75	25	3
Front to Back Load on Back Leg	150	50	1
Side Load on Arms	50	25	1
Side Load on Legs	200	50	1

The external frame consists of two vertical extension shaft sleeve bearings that are joined together at one end by two Tees and a crossbar to form a second U-shaped frame. Diameter of the pipe used in the internal frame is one inch; diameter of the pipe used in the external frame is 1-1/4 inches. These frames are adjusted during construction so that the internal extension frame is free to slide up and down inside the external frame.

The external frame differs from the internal in that the cross bar passes through a sleeve (crossbar sleeve) that acts as a bearing. This sleeve has a slot cut into it that allows a rod-end to be attached to the crossbar, Figure

attached to this rod-
 end of the cylinder is attached to the cross bar of the internal frame at its

the internal load frame necessarily follows. The action of the air cylinder is

and directed manner to the seat of the sofa. Importance of the load frame to
 the cylinder lies in the fact that the frame prevents side thrust forces from
 transmitted to it. Thus, only axial forces are applied to the piston rod
 and the neck bushing of the cylinder.

Length of retraction

vertical direction upward
 is controlled both by the

the cylinders and also by
 positive stops or collars

Figure 7a. These may be
 positioned on the internal

members to limit the

frame may be raised.
 Collars similar to these

extreme upper end of
 these members in order

movement of the frame
 () in case a seat
 foundation should

this

movement is limited only **Figure 7a. Details of construction of vertical load frames for
 seat load tests.**

provided by the seat or
 by the length of stroke of the cylinder.

A bill of materials for each of the seat load frames is given below.

Bill of Materials

- 2 each, extension shafts, 1 inch x
- 2 each, Ells, 1 inch
- 1 each, crossbar, 1 inch x 5-
- 2 each, setscrew collars, 1 1/4 inch inside diameter

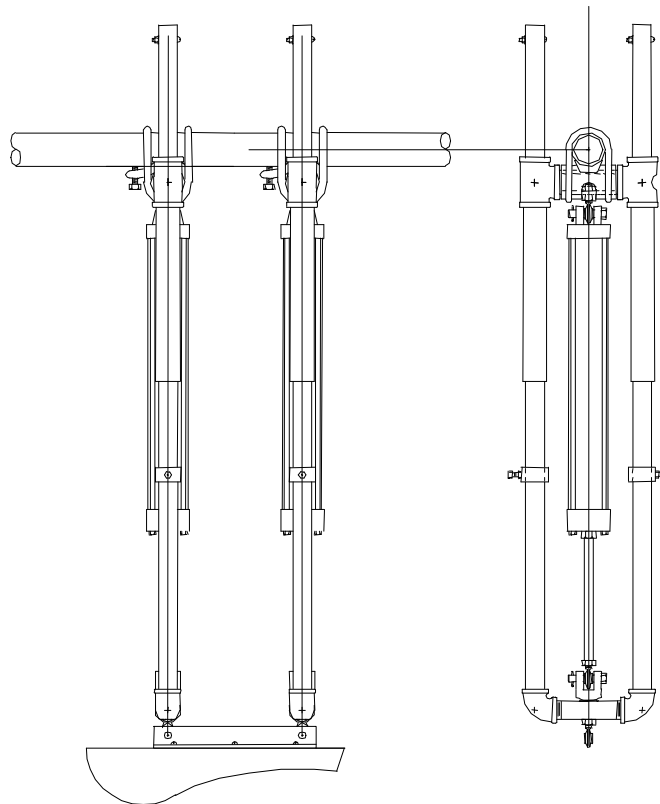

- 2 each, extension shaft sleeve bearings, 1-1/4 inch x 16 inch
- 2 each, Tees, 1-1/4 x 1-1/4 x 2 inch
- 1 each, crossbar, 1-1/2 inch x 5 inch
- 1 each, crossbar sleeve, 2 inch x 3 1/2 inch, heavy wall

In constructing these frames, it is necessary to insure that the spacing between the longitudinal axes of the vertical extension shafts in the internal frames is identical to that between the longitudinal axes of the extension shaft sleeve bearings in the external frame.

The external frames are supported by a length of 2-inch diameter pipe that passes in a horizontal direction above the crossbar sleeves of the external load frames, Figure 7b. The clevis end of the air cylinder is attached to the external load frame by means of a male rod-end that threads through a hole in the external load frame crossbar into a nut contained within the crossbar itself, Figure 7b. The 2-inch diameter heavy wall sleeve is slotted halfway around its circumference with a one-inch wide slot to allow the external sleeve to rotate a few degrees around the crossbar. This allows the load frames to swing in a front to back direction. A slot may be cut in the sleeve by first drilling a one-inch diameter hole through the 2-inch diameter sleeve at mid-length and then cutting out the wall on the one side with a hacksaw to form a slot. A one-inch diameter hole drilled through the outside wall of one of the Tees in the external load frame allows a nut to be inserted into the crossbar and held while the male rod-end is threaded into it. A long pair of tweezers can be used to insert and hold the nut.

Two rod-ends and one clevis are needed to complete the frame. They have not been included in the bill of materials since they must be sized to agree with the air cylinder used. The extension shaft stops have not been described in detail; however, they can be constructed from short lengths of 1-1/4 -inch diameter pipe. A hole is first drilled through one side of the pipe. A nut is then positioned over this hole in such a position that the longitudinal axis of the nut coincides with the corresponding axis of the hole and is then welded in place. A bolt or setscrew threaded into the nut is then used to lock the collar in place on the extension shafts. Alternatively, setscrew collars for conventional drive shafts may be adapted to this purpose.

3.1.2 Construction of the Seat Load Head

The configuration of the seat load head used in the test is shown in Figure 8. This load head is identical to that specified by the Society of Automotive Engineers for tests of automotive seating (SAE, 1961). These heads may be constructed by laminating together 1-inch thick pieces of lumber that have first been

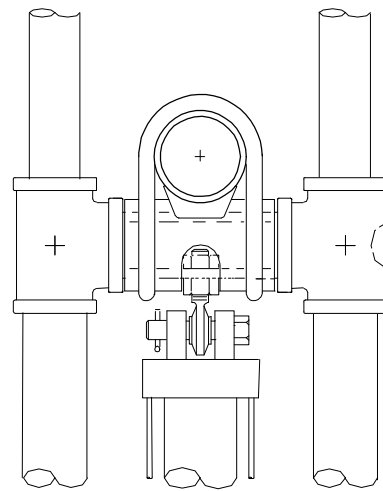

Figure 7b. Details of crossbar sleeve bearing.

cut roughly to shape. The resultant assembly may then be sanded with a belt sander to produce the desired form.

Brackets, which may be cut from angle iron, are attached to the top face of the load head to provide points of attachment to the seat load frame, Figure 8. The connection between the load head and the load frame is affected by means of rod-ends. Position of the hole through the brackets along with the spacing of the brackets with respect to one another determines the freedom of movement of the head; hence, it may be necessary to experiment to obtain the proper location and spacing for the specific rod-end used.

The weight of the head at each of the two load points is determined, and the heads then weighted with steel or lead to bring the total weight of load head plus load frame to a standard value such as 50 pounds at both the forward and the rear load points.

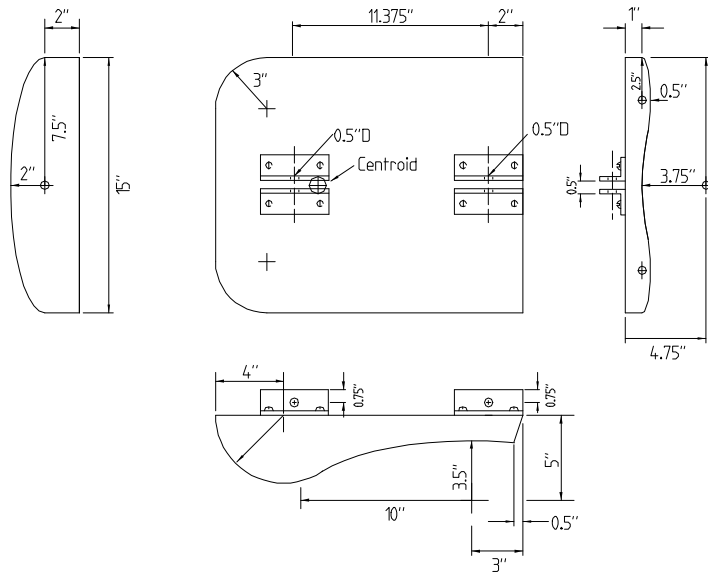

Figure 8. Seat load head dimensions.

3.2 Apparatus for Back Load Tests

3.2.1 Backrest Load Frames

An overview of a load frames used in the backrest tests is given in Figure 9a. Working drawings of a backrest load frame are given in Figure 9b. A bill of material for each of these frames is given below.

Bill of Materials

Internal Load Frame

- 2 each, Ells, 1 inch
- 2 each, extension shafts, 1 inch x 48 inch
- 1 each, crossbar, 1 inch x 6 inch

External Load Frame

- 2 each, reducing Tees, 1 inch x 1-1/4 inch
- 1 each, crossbar, 1 inch x 5-1/2 inch

- 2 each, extension shaft sleeve bearings, 1-1/4 inch x 16 inch
- 4 each, Tees, 1-1/4 inch
- 2 each, close nipples, 1-1/4 inch (to form crossed Tees)
- 4 each, close nipples, 1-1/4 inch (for bearings in crossed Tees)
- 1 each, cross pin, 1 inch x 12 inch
- 2 each, end caps, 1 inch (for cross pin)

Swivel Support Column

- 1 each, Tee, 1-1/4 inch
- 1 each, close nipple, 1-1/4 inch
- 1 each, reducing coupling, 1-1/2 to 2 inch
- 1 each, swivel column, 1-1/2 inch x 20 inch
- 1 each, swivel column sleeve bearing, 2 inch x 18 inch
(heavy-wall pipe)

The load frames for testing the backrests are similar to those for testing seats, but important differences do exist, Figure 9a. Again, each load frame consists of two basic units - an internal and an external frame. The internal frame consists of two extension shafts constructed of 1-1/4 inch diameter pipe that are joined together at one end by a crossbar to form a U-shaped frame. The external frame consists of two extension shaft sleeve bearings joined together at one end by a crossbar to form a second U-shaped frame. These pipes are 1-1/4 inches in diameter, however, so that the internal frame is free to slide within it. Crossed Tees, attached to the two free ends of the extension shaft sleeve bearings of the external frame act as bearings for a shaft inserted through them. These two bearings together with the one inch diameter pipe

inserted through them form part of a hinge that allows the backrest load frame to pivot up and down and thereby follow the natural movement of the backrest as the load head pushes against it.

The other half of the hinge is formed by a Tee attached to the end of the 1-1/2 inch diameter pipe that acts as a vertical load frame swivel

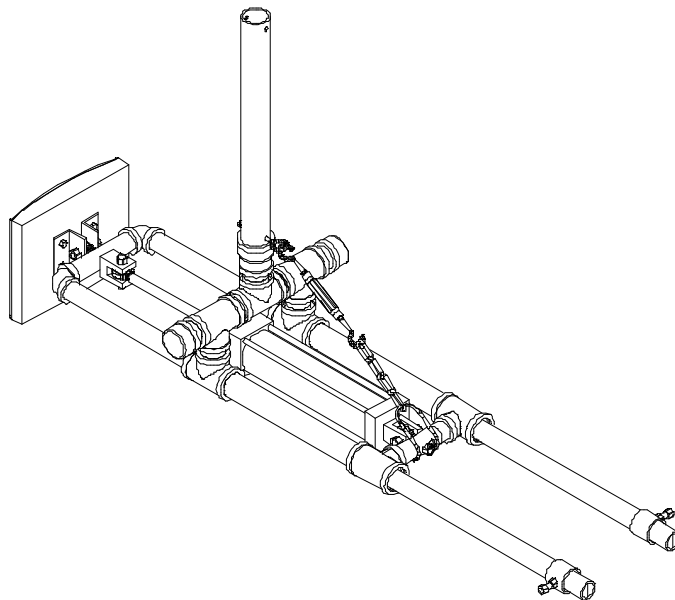

Figure 9a. Overview of backrest load frame.

column. This pipe, or swivel support column, in turn, fits inside of a two-inch diameter heavy wall sleeve (swivel sleeve bearing - schedule 80 pipe), Figure 9b. This two-inch sleeve is firmly attached to the testing machine frame in a vertical position by means of scaffolding clamps; the 1-1/2 inch diameter pipe is free to rotate within it so that the load frame and the load head attached to it are free to swing from side to side. The 1-1/2 inch diameter pipe is prevented from sliding out of the two-inch diameter sleeve by means of a pin, which passes through the inner pipe near its upper end,

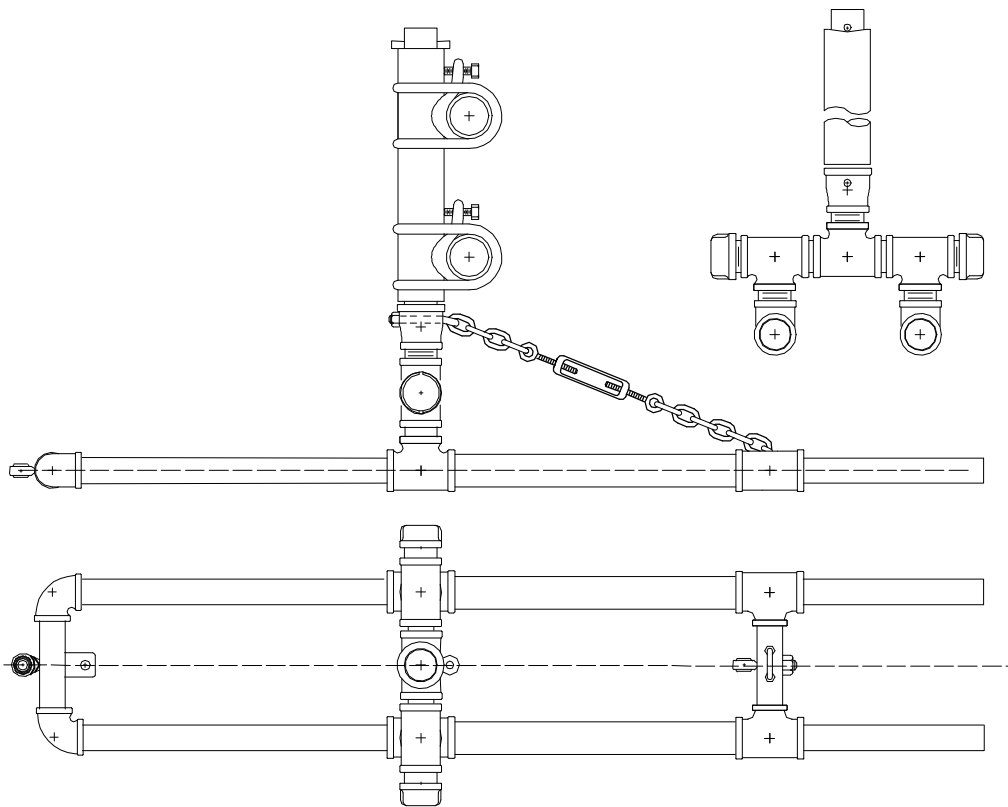

Figure 9b. Working drawing of backrest load frame.

Figure 10. This pin rides on the upper end of the sleeve and carries the full weight of the load frame apparatus. A shallow V-groove is cut into the top of the sleeve so that the weight of the backrest load frame acting on the pin causes the pin to index into the bottom of the groove in the same location each time the cylinder retracts. This arrangement allows the load frame and load head to follow any side to side movement of the backrest during a load cycle and then return and index in the proper starting position automatically on the unload cycle.

The head of the air cylinder is supported by means of a small chain that is looped over the hinge pin and the body of the cylinder. Ends of the chain are joined together by means of a spring that allows some movement of the cylinder and thereby avoids binding. The cylinder should be positioned in the frame so that the rod-end of the piston rod fits into the eye of the clevis

without applying sidethrust force to the piston rod. If a clevis with a slightly oversized opening is used to attach the rod-end-bearing to the load frame, and if it is turned so that the pin is in a vertical position, it will allow the rod-end bearing to slide up and down on the pin slightly and thus relieve any accompanying side thrust forces on the piston rod as the load frame extends and retracts as it deflects under load.

The rear end of the air cylinder, which is equipped with a clevis, is attached to the external load frame by means of a male rod-end-bearing. The body of the bearing passes through the crossbar of the external load frame and is secured with a nut on the opposite side.

A 1/4-inch or 5/16-inch diameter U-bolt is attached to the crossbar of the load frame as shown in Figure 9b—a slightly modified U-bolt system is shown in Figure 9a. This U-bolt provides a point of attachment for the turnbuckle/chain linkage that controls the angle of the load frame with respect to the horizontal.

The complete linkage is shown in Figure 9a. The rear of the external load frame should be weighted so that the total load frame is just balanced when the internal load frame is fully extended. If the backrest deflects downward as it is loaded, the load head and load frame are free to follow. When the internal load frame retracts, however, the weight at the rear of the external load frame causes the entire load frame to return to its original starting position. Normally, the weight of the air cylinder is sufficient to cause this action without the addition of external weights.

The load head is attached to the end of the load frame by means of a rod-end and bracket, Figures 9b and 11. Clearances between the bracket, the rod-end, and the end of the load frame are such that the load head itself is free to pivot both up and down and rotate from side to side predetermined amounts about the rod-end. This freedom of movement allows the load head to adjust to local changes in the shape and angle of the backrest.

3.2.2 Backrest Load Heads

Configuration of the backrest foundation load heads is shown in Figure 11. This load head is similar to that specified in British Standard 4875 for the testing of sofa backs (BSI, 1975). The load heads may be fabricated from solid wood. Angle iron brackets attached to the back of the load head may be used to form a clevis. A male rod-end whose shaft is bolted to the load frame connects the load head to the load frame, Figure 9b. Articulation of the load head is governed by the opening width of the clevis

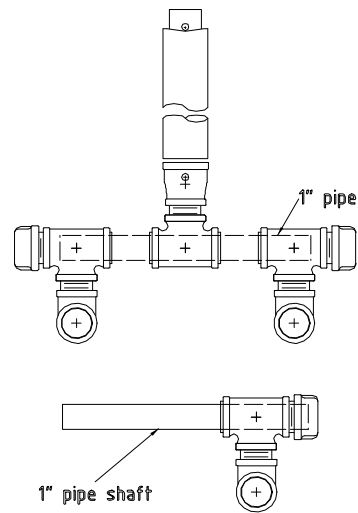

Figure 10. “Exploded view of backrest frame hinge.

and by the location of the hole. Some experimentation may be necessary to determine the optimum location for the specific rod-end used. In general, however, the load head should have sufficient freedom of movement to follow the deflection of the backrest without binding.

3.3 Load Calibration

A force dynamometer may be used to calibrate and periodically monitor the force exerted by the air cylinders on the furniture. One such force dynamometer and an accompanying load frame are shown in Figure 12. This dynamometer has a 1000-pound load capacity and an 8-inch diameter face that has been divided into 5-pound increments for easy reading. A frame constructed from pipe and scaffolding clamps in which the dynamometer and an air cylinder can be placed for calibration is also shown. Desired force levels are obtained by adjusting the air regulator while the air valve is operating at its normal cyclic rate. Design of the testing equipment is such that a cylinder can readily be detached from the testing machine and inserted in the calibration frame. When matched cylinders are used, however, a spare cylinder mounted in the calibration frame can be used to calibrate identical cylinders without removing them from the testing machine. An extra cylinder is required, of course, if this latter procedure is followed.

When calibrating cylinders at high pressure levels, the cylinders may cause near impact loading on the force dynamometer that may damage the interior force-indicating mechanism. To reduce the rate of loading, speed control valves should be used to reduce the rate of loading.

3.4 Testing Machine Frame

The external testing machine frames previously shown consist of a rectangular skeletal steel framework fabricated from pipe and scaffolding clamps. This framework provides points of attachment for the various devices that are used to apply loads to the furniture, and it also provides a means of supporting and holding the furniture in place while it is being tested.

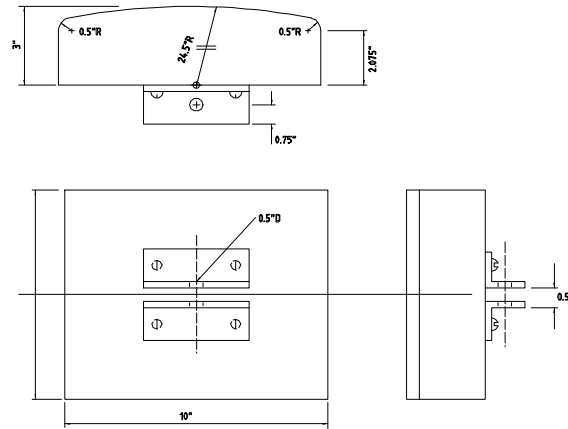

Figure 11. Configuration of backrest foundation load head.

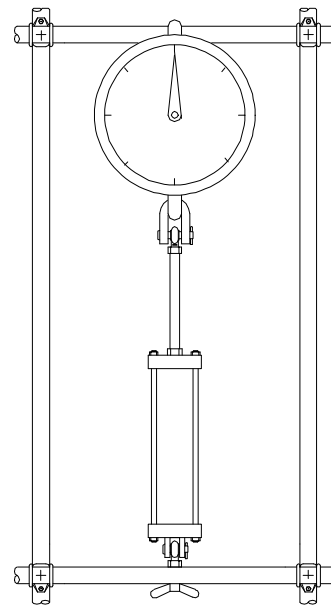

Figure 12. Force dynamometer and load frame.

Overall size of the testing machine is not critical, but it must provide sufficient space for the sofa and loading apparatus to be mounted properly as well as sufficient space for servicing the equipment. A typical testing machine framework is shown in Figure 13. Corner posts about 9-feet high are anchored to the floor.

Crossbars are attached to these posts to form the frame of the machine. All of the frame members are constructed of nominal 2-inch diameter pipe.

Lightly loaded members, and in particular, columns may be constructed of schedule 40 pipe; heavily loaded cross bars, on the other hand should be constructed of schedule 80 pipe. Scaffolding clamps, Figure 14, are used to join the members together to form a rigid frame. The frame is attached to the floor by means of special floor flanges, Figure 15. These

flanges are particularly useful for attaching the frame corners to single anchor bolts set in concrete floors. Standard floor flanges may be used for attaching the frame corners to wooden or similar floors.

The scaffolding clamps provide considerable rigidity to the frame, and it should not be necessary to brace the frame in any way. Should this prove necessary, however, additional pipes and clamps may be used to insert diagonals in the side frames.

The frame should be given regular maintenance while testing; specifically, the setscrews in the scaffolding clamps should be regularly inspected and tightened if necessary. Scaffolding clamps may also

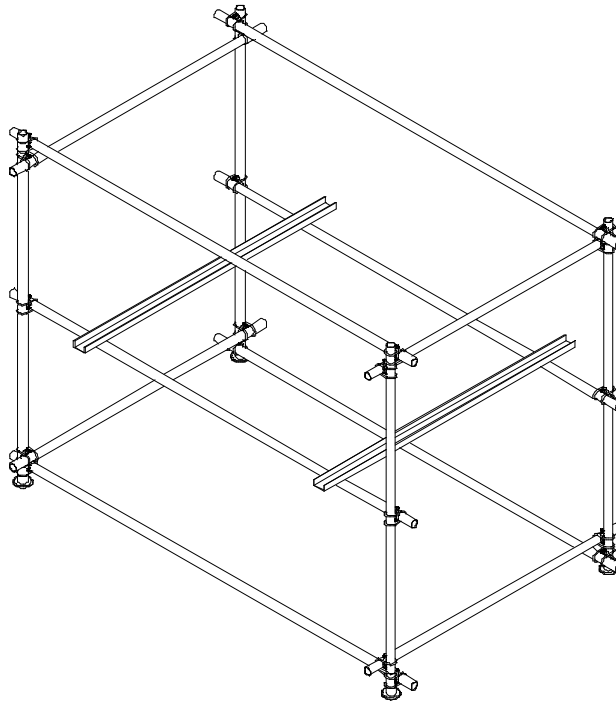

Figure 13. Overview of testing machine frame. The frame measures 8 ft. high by 12 ft. across.

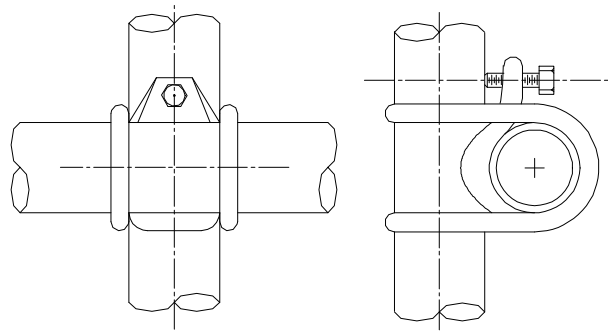

Figure 14. Scaffolding clamp used to fabricate main testing machine frame.

break if they are subjected to high load levels for a great number of cycles. If this situation should occur, additional members should be added to the testing machine at critically stressed points to share the load. Safety chains hooked over the tops of the corner posts or over the top of intermediate posts should be used to ensure that a crossbar cannot fall if a clamp should loosen.

3.5 Air Cylinders

At least six air cylinders are required to carry out the tests described in this paper, but it is convenient to have an extra cylinder on hand that can be used solely for load calibration purposes. Cylinders with a bore of 2-1/2 inches and a stroke of 18 inches are well-suited for use in the tests and are compatible with the load frames developed for the seat load and back rest tests, but cylinders with a stroke of 10 to 12 inches will be found more convenient for other tests. The most important criteria is that the cylinders must have sufficient stroke to allow the furniture to deflect fully; they must, for example, have sufficient stroke to allow the seats and the backrests to deflect fully. Cylinders with larger bore diameters may also be used. If cylinders with too large bore diameters are used, however, they may be difficult to calibrate and control at lower load levels because of the practical limits of accuracy of the air regulators at low load levels. The quality of the air cylinders used is optional, but medium duty cylinders should give satisfactory service under laboratory conditions.

To simplify attachment of the cylinders to the load frame, the cylinders should be equipped with a clevis mount. In addition, the ends of the piston rods should be threaded internally to receive a male rod-end bearing although external female rod-end bearings can also be used with externally threaded piston rods.

3.5.1 Cylinder Attachment Assembly

The air cylinders are attached to the main frame of the testing machine by means of a male rod-end and a short length (4-inch long) of 2-inch diameter pipe, Figure 16a, which will be called a cylinder attachment assembly. The 4-inch long pipe has a 1/2-inch diameter hole drilled through it crossways at mid length that receives the threaded portion of a

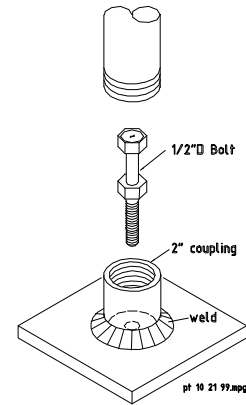

Figure 15. Details of floor flange assembly.

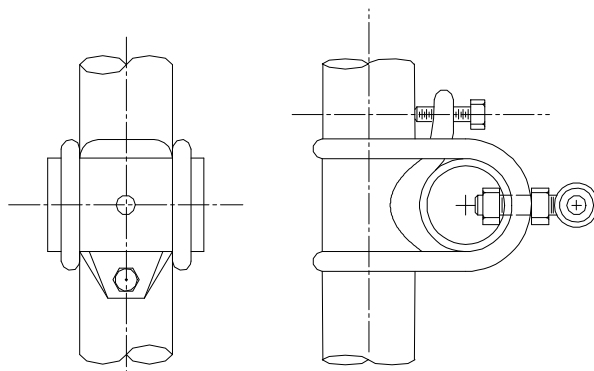

Figure 16a. Details of cylinder attachment assembly.

rod-end. After the rod-end is inserted in the hole, it is held in place by external and internal nuts, Figure 16a. An attachment of a cylinder to the testing machine frame is shown in Figure 16b.

3.5.2 Cylinder support Assembly

The air cylinders are supported in a horizontal position, when needed, by means of a cylinder support assembly. This assembly consists of a cylinder support frame, Figure 16b, that is made of two lengths of 1-1/2-inch diameter pipes joined together by a 90 degree ell, a length of chain or a strap, and a spring. One leg of the cylinder support assembly is inserted into the top end of an upright to which a cylinder attachment assembly is connected. The chain is then looped over the horizontal arm of the cylinder support frame, around the barrel of the air cylinder, and connected to itself by means of a small spring.

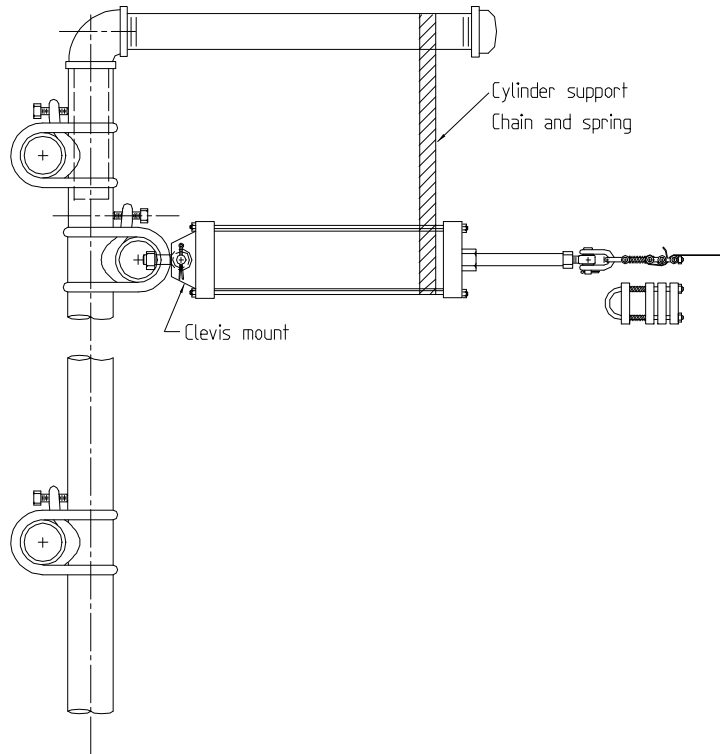

Figure 16b. Cylinder attachment and support assembly.

The strap or chain and spring should be adjusted so that no side thrust forces are applied to the shaft of the cylinder.

3.5.3 Load Application

For applications of the type shown in Figures 4 and 5, i.e., side load test on arms and load test on legs, loads are applied to the furniture by means of a length of chain or a strap. The chain is looped around the part of the furniture frame that is to be tested (an arm, for example) and is then attached by means of a pivot pin to one end of a double clevis (or single clevis if the chain is large enough to permit the eye of the clevis to pass through a loop of the chain.). The other end of the double clevis is then attached by means of a pivot pin to the cylinder rod-end, Figure 17. It should

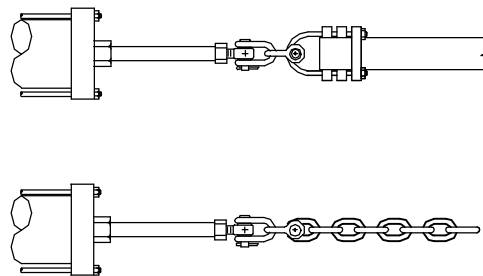
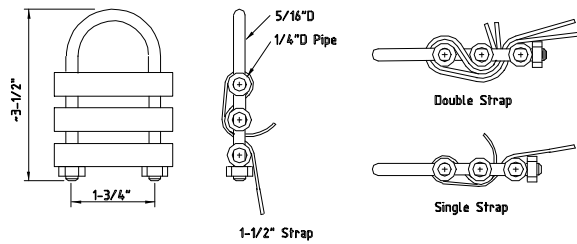

Figure 17. Loads are transferred from air cylinders to furniture by means of strap (above) or chain (below).

be noted that two conventional clevises can be used back to back instead of a double clevis.

If straps are used instead of chain, then a fixture must be used to secure the end of the strap and also to obtain the necessary length adjustment. A simple



fixture of the type shown in Figures 17 and 18 may be used both to secure the end (or ends) of the strap and also to obtain the necessary adjustment for length. This fixture may be readily fabricated from a 5/16-inch diameter U-bolt and short lengths of 1/4 -inch diameter pipe. Larger sizes may be used if desired.

Figure 18. A simple end-connection for straps that holds the ends of the straps securely in place.

3.6 Air Control system

Standard 3/8-inch, three-way solenoid valves are used to control the flow of air to the cylinders. These valves control the flow of air to both sides of a cylinder, Figure 19. Pipe trees may be connected to the outlet ports of each valve so that three cylinders can be operated from each of the four valves (for the seat load test). Twenty-foot lengths of 3/8-inch ID diameter hose are used to connect the valves to the cylinders. Use of equipment of this size is mandatory to ensure that desired force levels can be developed and maintained. The main supply line should be properly sized to provide peak air demand during load cycles. Use of a 2-inch diameter feeder has been found useful. If supply lines are long, an air ballast tank should be located near the test apparatus.

Operating pressure is controlled by standard air regulators; oilers are included in order to provide the lubrication needed by the valves and air cylinders.

3.7 Electrical Control Circuit

An example of a hard wire electrical cyclic control system that may be used to carry out the tests is shown in Figure 20. A repeat cycle timer is used to control the length of the on/off portion of each cycle along with the rate at which the test is carried out, that is, 20 cycles

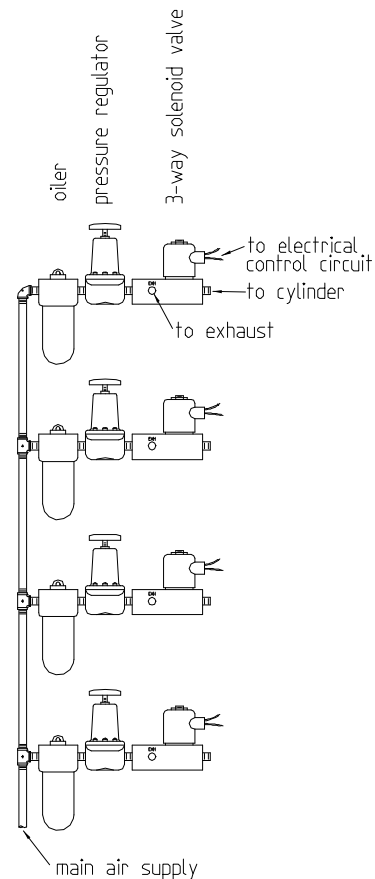

Figure 19. Example air control system.

per minute. The cam should be adjusted to obtain a 50 percent on/off cycles.

Electrically operated predetermined counters are used to count the number of cycles completed and to stop the test after a predetermined number of cycles have been completed. These counters have internal electrical switches that open when a preset number of cycles have been completed. The counters are wired into the electrical control circuit as shown in Figure 20.

Although this equipment works well, it should be noted that its use is not mandatory, and many users will choose to use simple process controllers

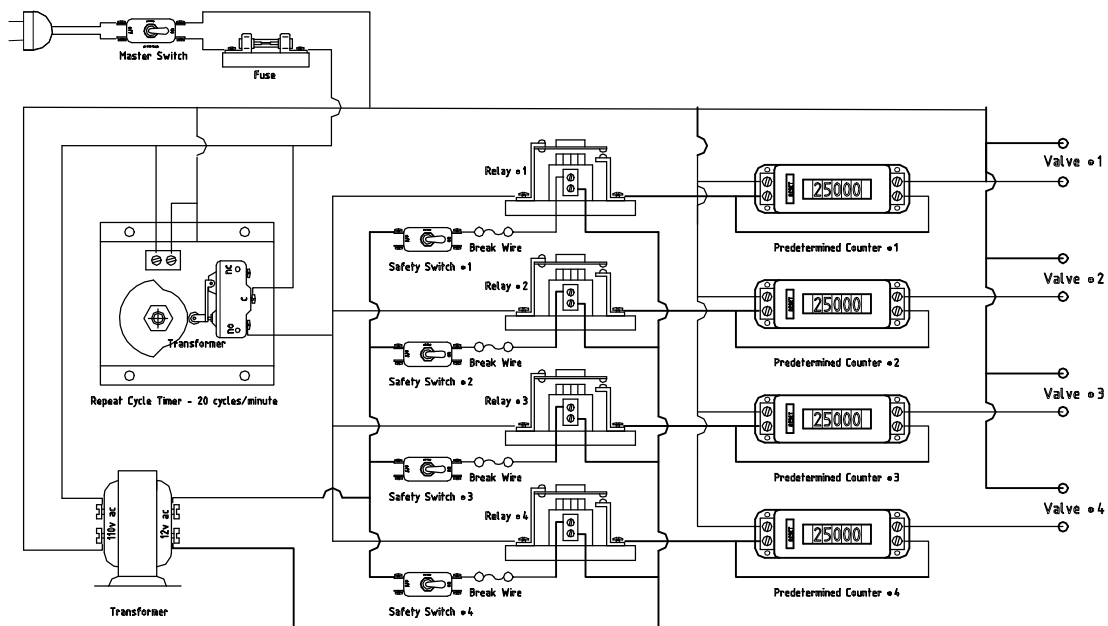

Figure 20. Example control system that may be used to control cyclic rate of loading and terminate test after predetermined number of test cycles have been completed.

to carry out the tests.

A break wire, Figure 21, may be used to stop the test when a part breaks or fails. The wire used in the test should be rubber coated instrument lead wire. One end of the wires should be attached to the “break wire” terminals shown in Figure 20 (The internal connection between these two terminal should be removed). The wires are then passed over a main machine member (or other pipe) and a full turn taken around the pipe. The free ends are then attached to a short length of wire equipped with alligator clips that passes around the part under test as shown in

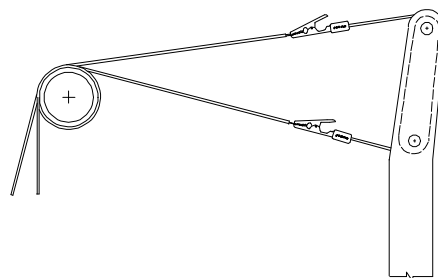

Figure 21. Break wire connection used to terminate test when part fails.

Figure 21. The “tightness” or “slack” of the section of the wire between the pipe and the part under test may be easily adjusted by loosening the loop of wire around the pipe. Once the length of wire has been properly adjusted, however, the loop around the pipe will not move.

4.0 References

- British Standards Institution. 1975. BS 4875. *Strength and Stability of Domestic and Contract Furniture*. London.
- Eckelman, C.A. 1978a. *Development of Performance Tests for Upholstered Furniture—Development of Tests and Results of Test Program*. National Technical Information Service. Department of Commerce, Washington, D.C.
- Eckelman, C.A. 1978b. *Development of Performance Tests for Upholstered Furniture—Design of Equipment*. National Technical Information Service, Department of Commerce. Washington, D.C.
- Society of Automotive Engineers. 1961. *SAE Motor Vehicle Seating Manual*. Warrendale, Pa.
- Upholstered Furniture Test Method*. FNAE-80-214. General Services Administration. Wash., DC.