



# Classic sofa

*assembly instructions*





**Smooth & Wrinkle-Free Fabric Covers:**

In addition to these printed instructions, you may want to watch our beauty tips videos on the customer service page of our website. The videos show demonstrations on how to apply the fabric covers and make them smooth and wrinkle free.



**Renewability:** Individual foam and fabric parts are available. You no longer have to worry that something will happen and you'll just have to live with it. From pet attacks to paint spills, it's easy to recover from a furniture accident.

# CUSHIONS

**Foam:** The seat cushions will feel firm at first. That's intentional, since firmer foam lasts longer. You can shorten the break-in period by putting the cushions on the floor and walking on them for a few minutes.



**Fabric Exchange:** To use our 30-day fabric cover exchange program, contact us and we'll lead you through the process. Keep the covers out of actual use to preserve them in new, unused, and clean condition. Fold them neatly when repackaging to avoid wrinkles.

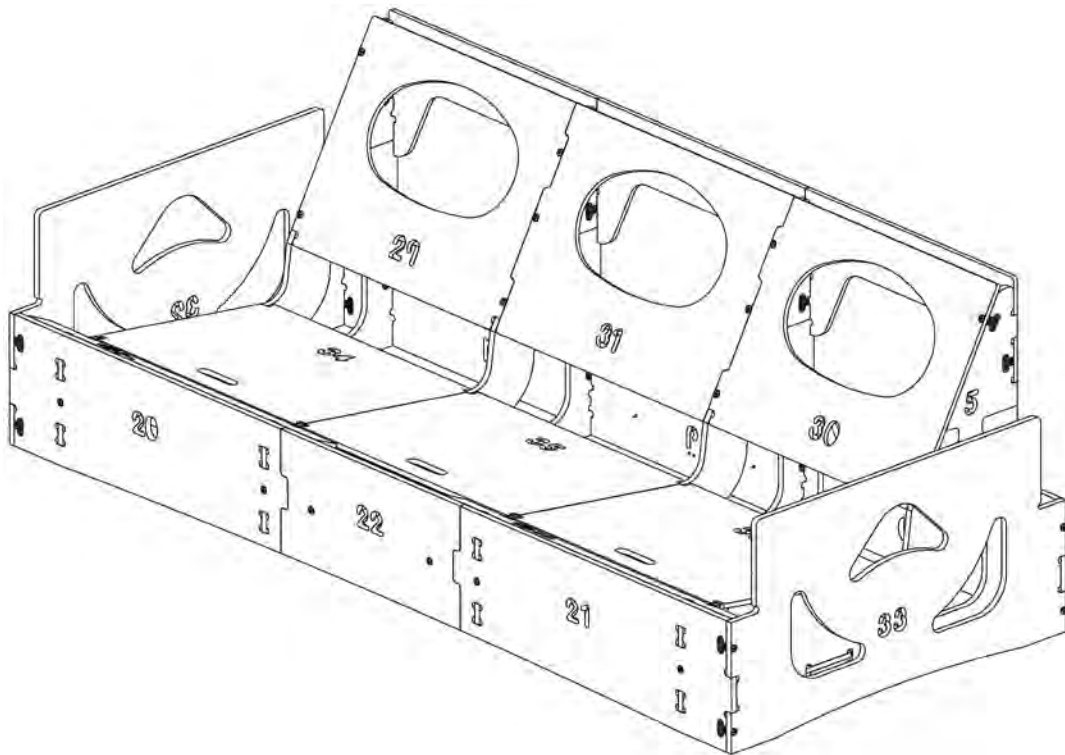
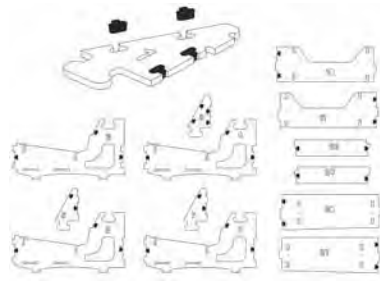

Tools needed: Phillips Screwdriver or powered drill with a Phillips screwdriver bit.

A sanding pad is included in case you wish to smooth over any of the surfaces or edges after the frame is assembled. It is not necessary to sand any of the frame parts during assembly. No glue will be used during assembly. Item will be ready for use immediately.

# Frame Assembly

Open both boxes and set aside the foam and fabrics for later. Then take the wood parts out of the boxes. These parts are not packed in order of assembly so don't worry about getting them mixed up. They are all numbered for easy reference.

- 1** Open the parts bag and insert the black plastic T-connectors into the parts shown here. Throughout these instructions it is OK to use a hammer to tap the T-connectors and wood parts into position.

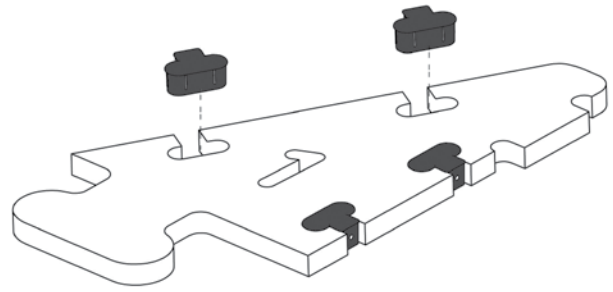
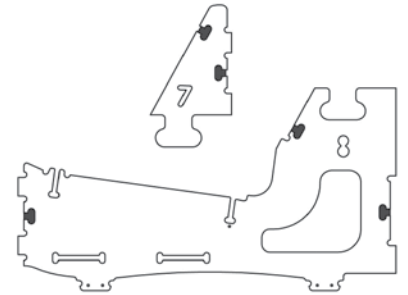
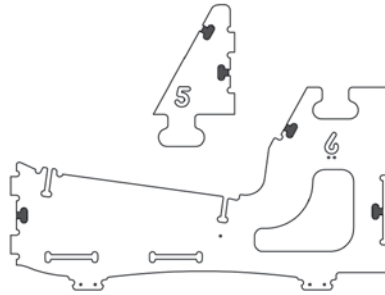
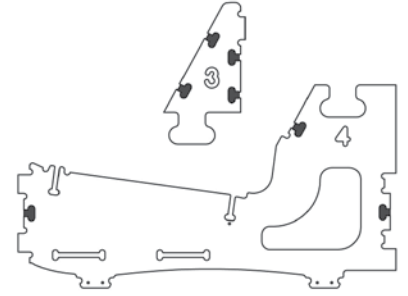
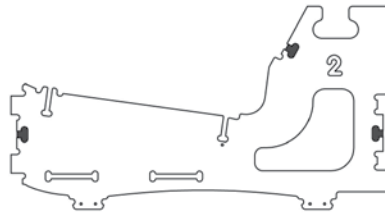
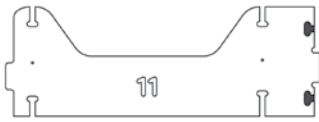
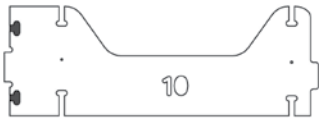

- 2** Attach black floor glides to the parts shown.

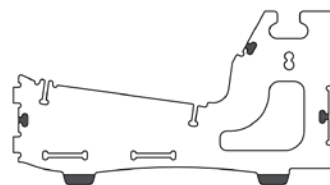
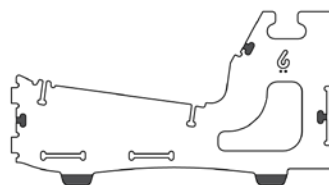
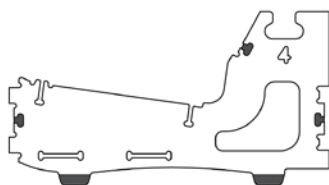
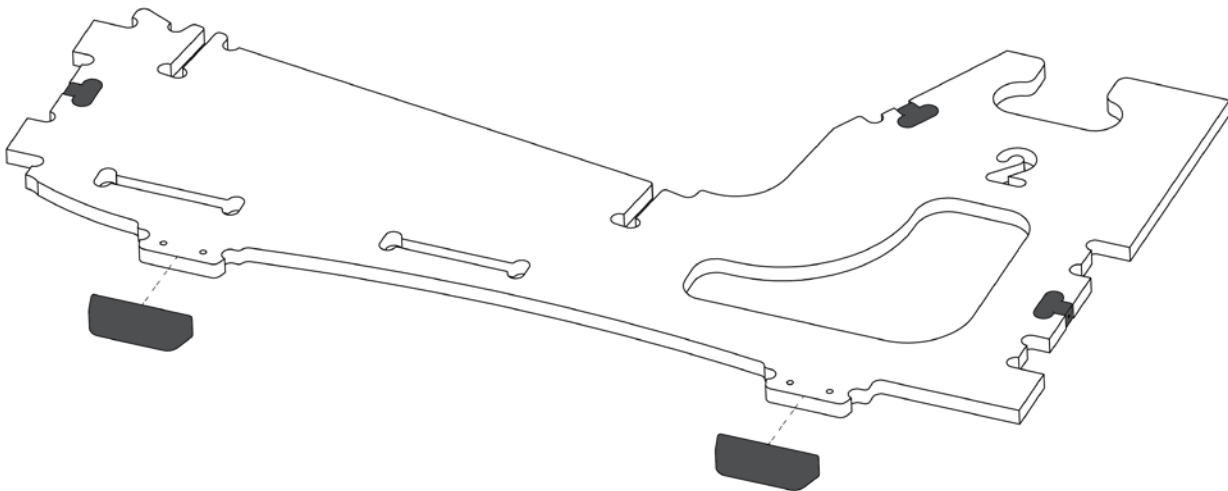

**3**

Connect parts 1 and 2 together. Repeat for parts 3 and 4, 5 and 6, 7 and 8.

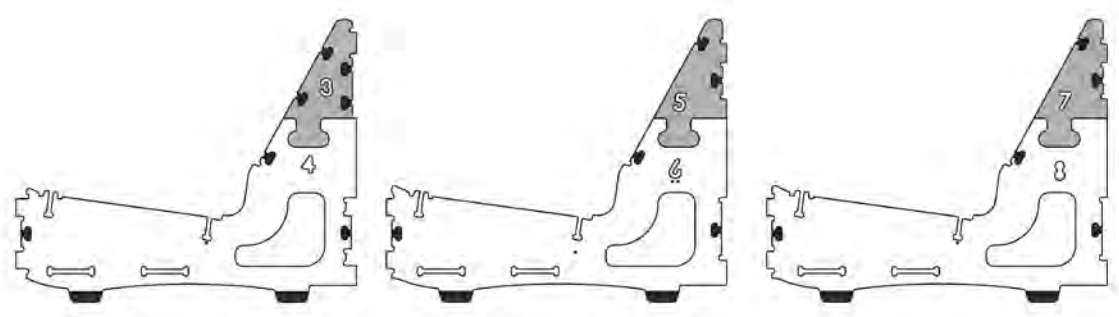
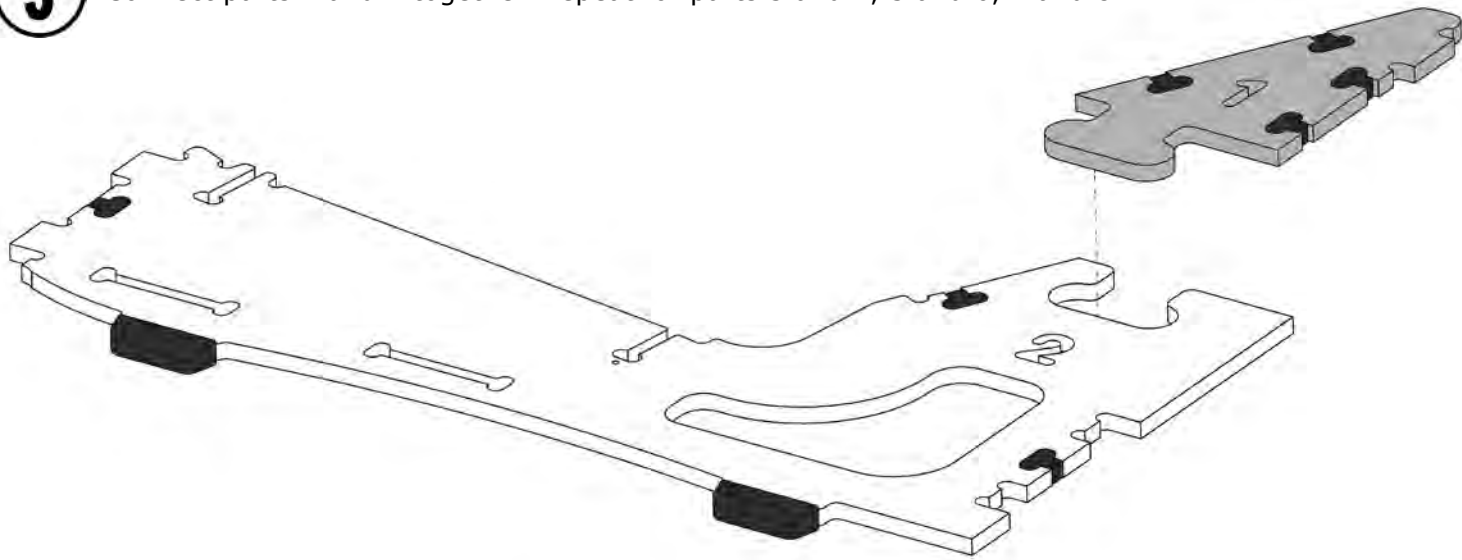

**4**

Slide part 9 onto parts 4 and 2. No screws are used in this step.

Detail Enlarged  
For Clarity

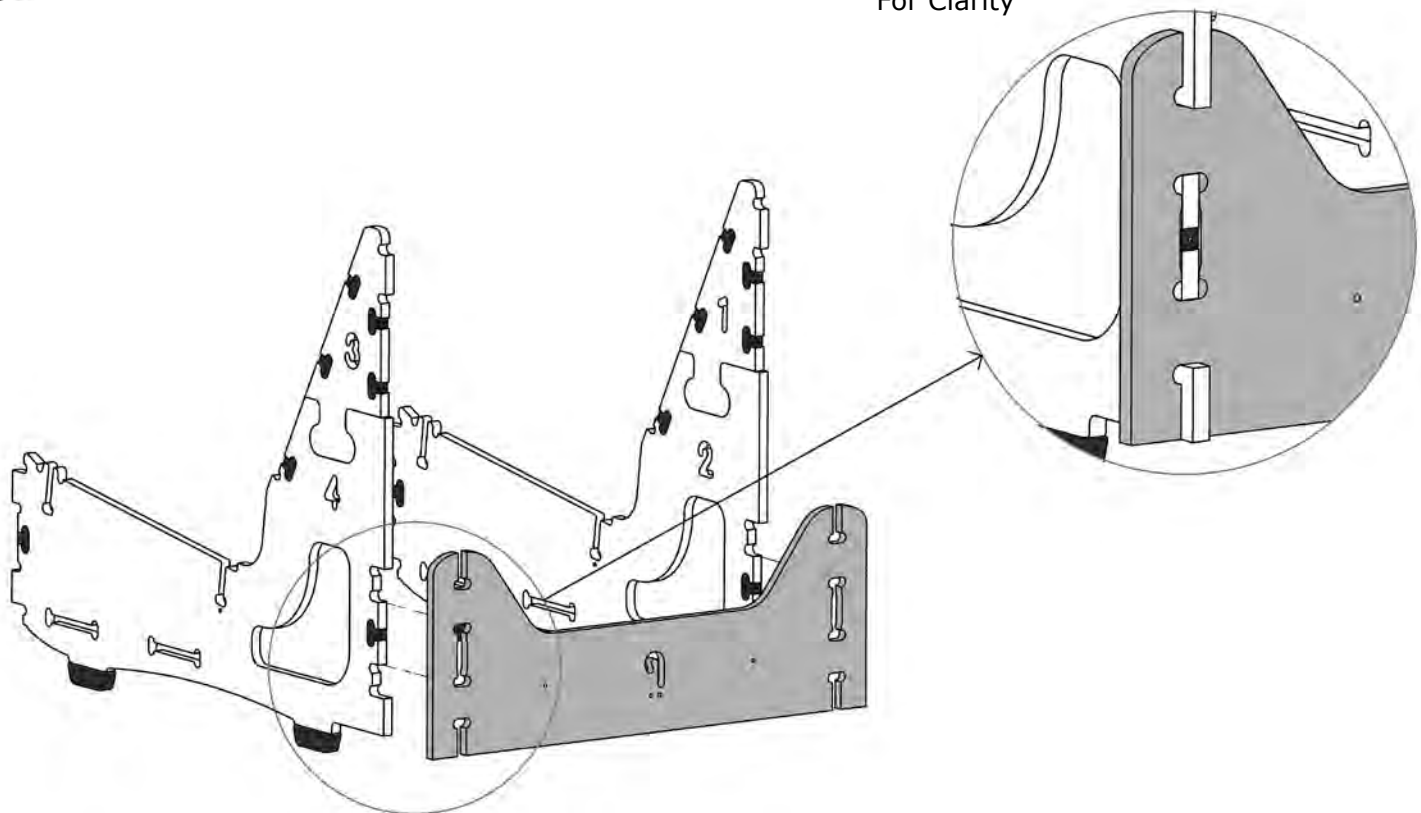

- 5** Move part 10 into position overlapping part 9 and secure with screw. (Make sure screw aligns with the hole in T-connector on part 4.) Move part 11 into position on the other side and secure with screw.

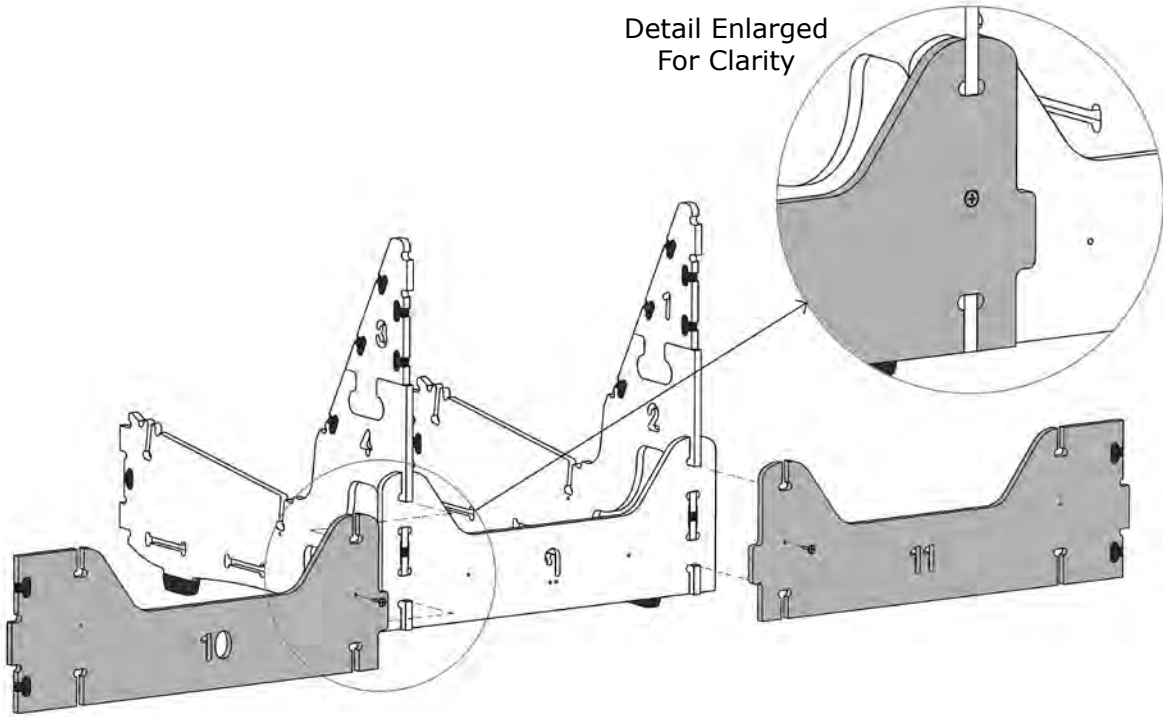

- 6** Align part 12 over part 9 and secure with two of the special size screws. (The special size screws for this step are in a small plastic bag labelled "For use with parts #12 and #22". These screws are slightly smaller so that they don't protrude.)

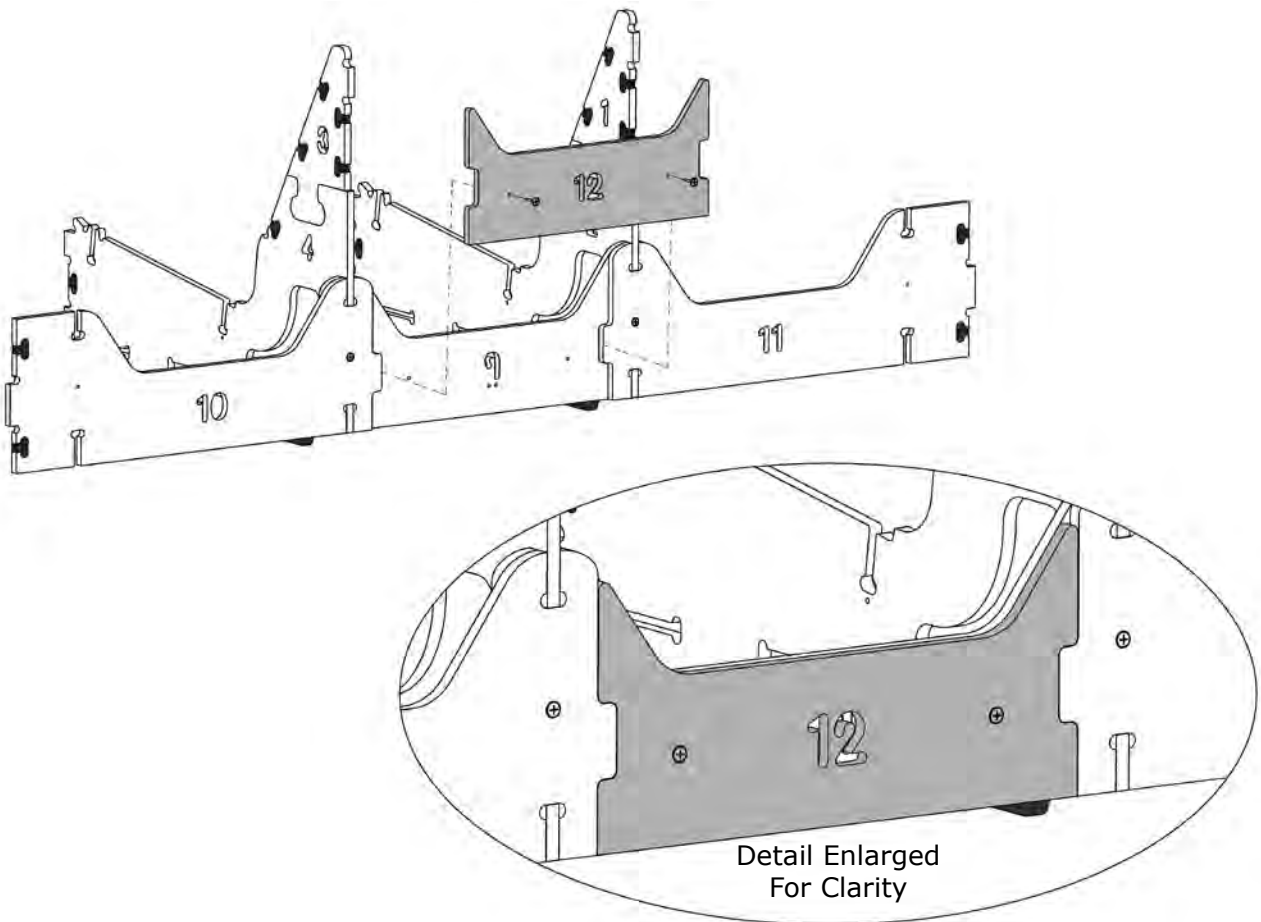

- 7** Slide part 6 into corresponding slots in part 10 and secure with screw as shown. Repeat the process for parts 8 and 11.

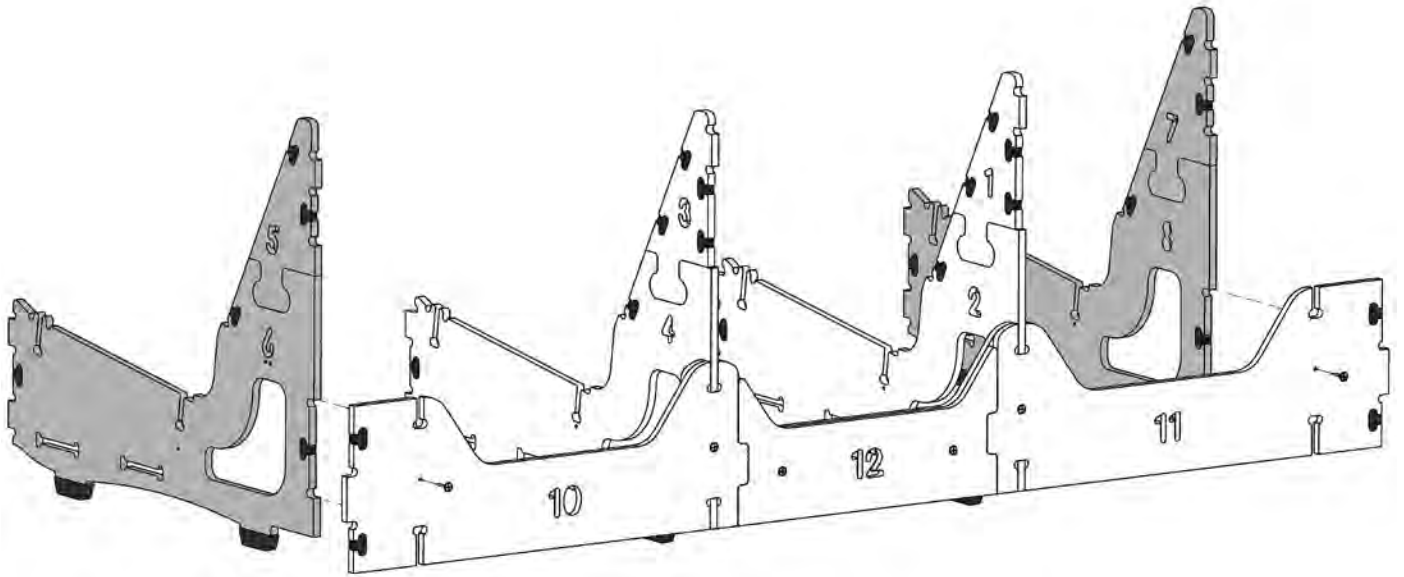

- 8** Align part 13 onto parts 5 and 3, secure with two screws. Align part 14 onto parts 1 and 7 and secure with two screws. Move part 15 into position between 13 and 14, secure with two screws.

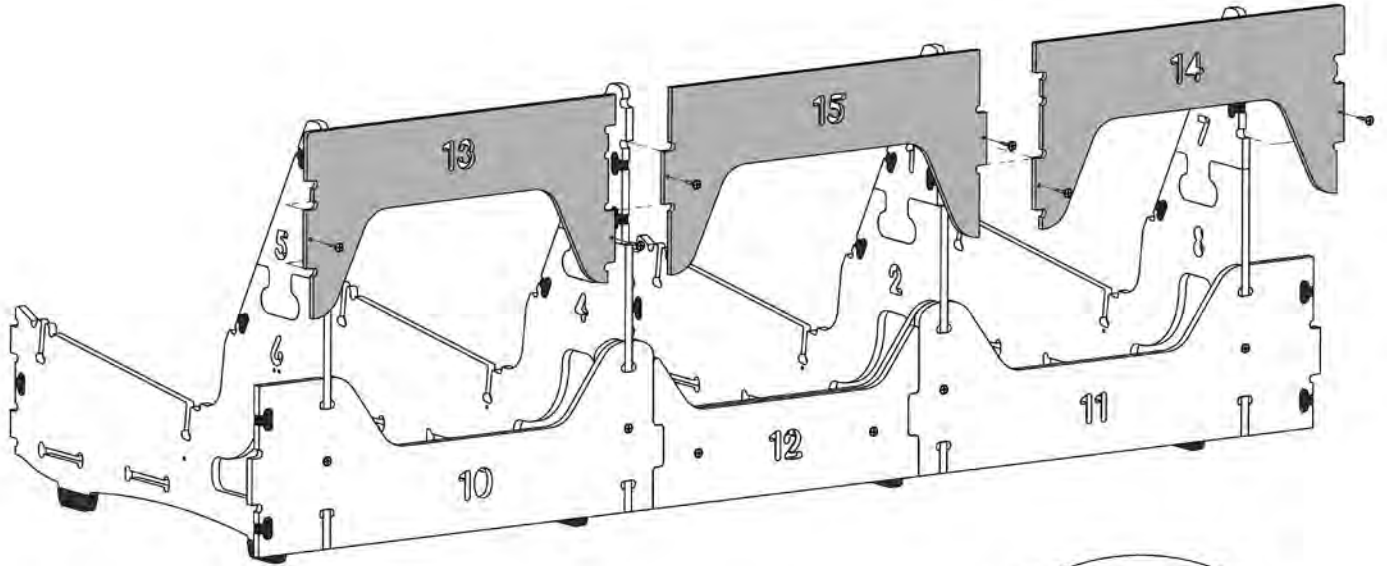

Detail Enlarged  
For Clarity

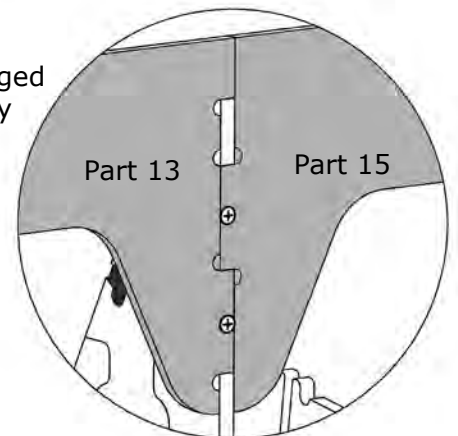

- 9** Spread parts 2 and 4 apart far enough to slide part 16 into slots on 2 and 4. (Refer to Top View A below).. Move part 8 out far enough to slide part 17 into the appropriate slots on 2 and 8. (Refer to Top View B below.) Follow the same procedure with part 18 on parts 4 and 6.

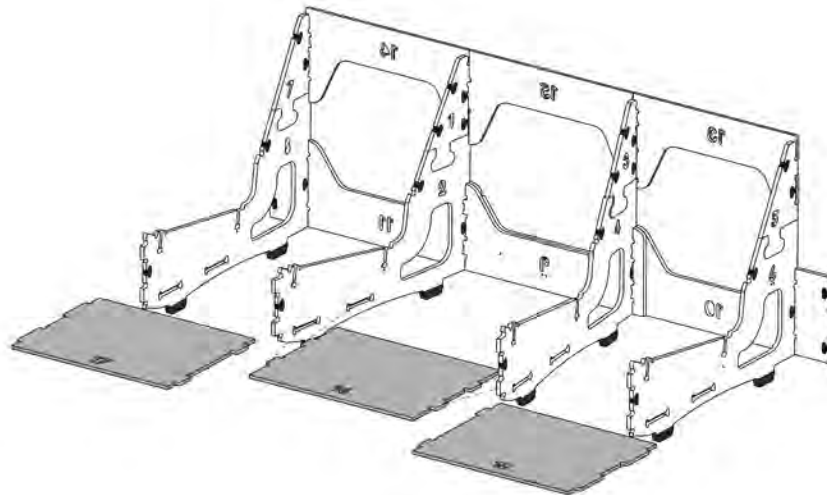

Top View A

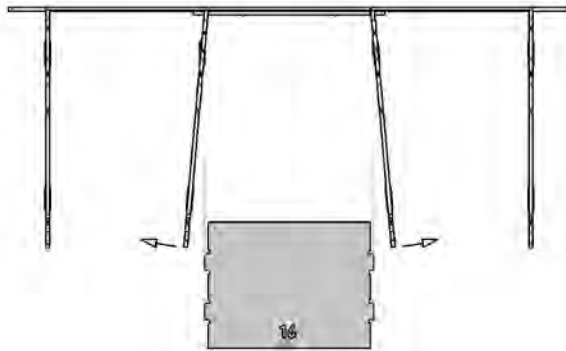

Top View B

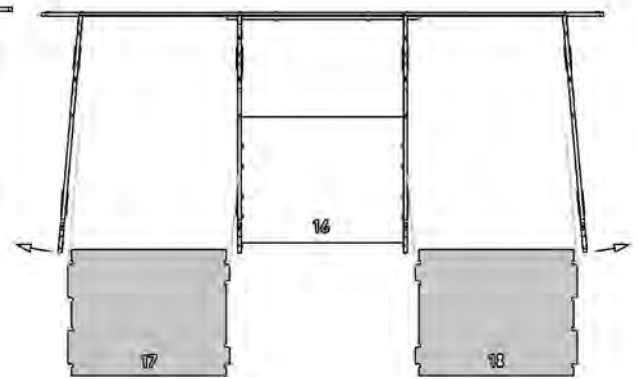

- 10** Slide part 19 onto parts 2 and 4. No screws are used in this step.

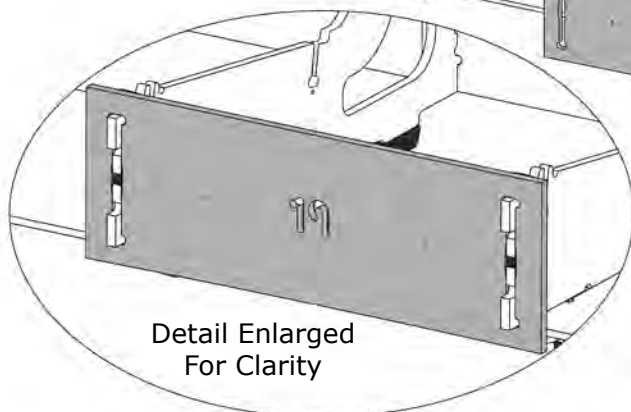
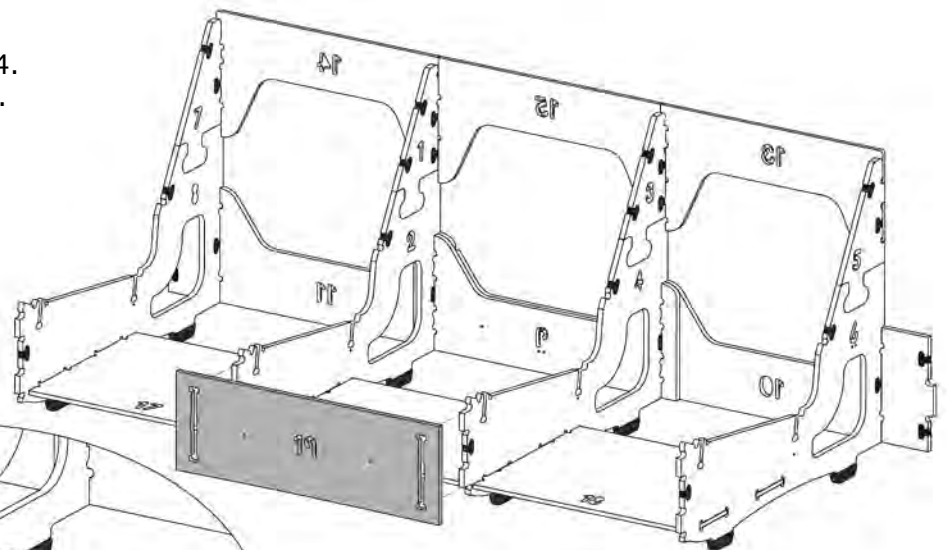

Detail Enlarged  
For Clarity

**11**

Move part 20 into position overlapping part 19 and connecting onto part 8, secure with two screws. Repeat process for part 21 on the other side.

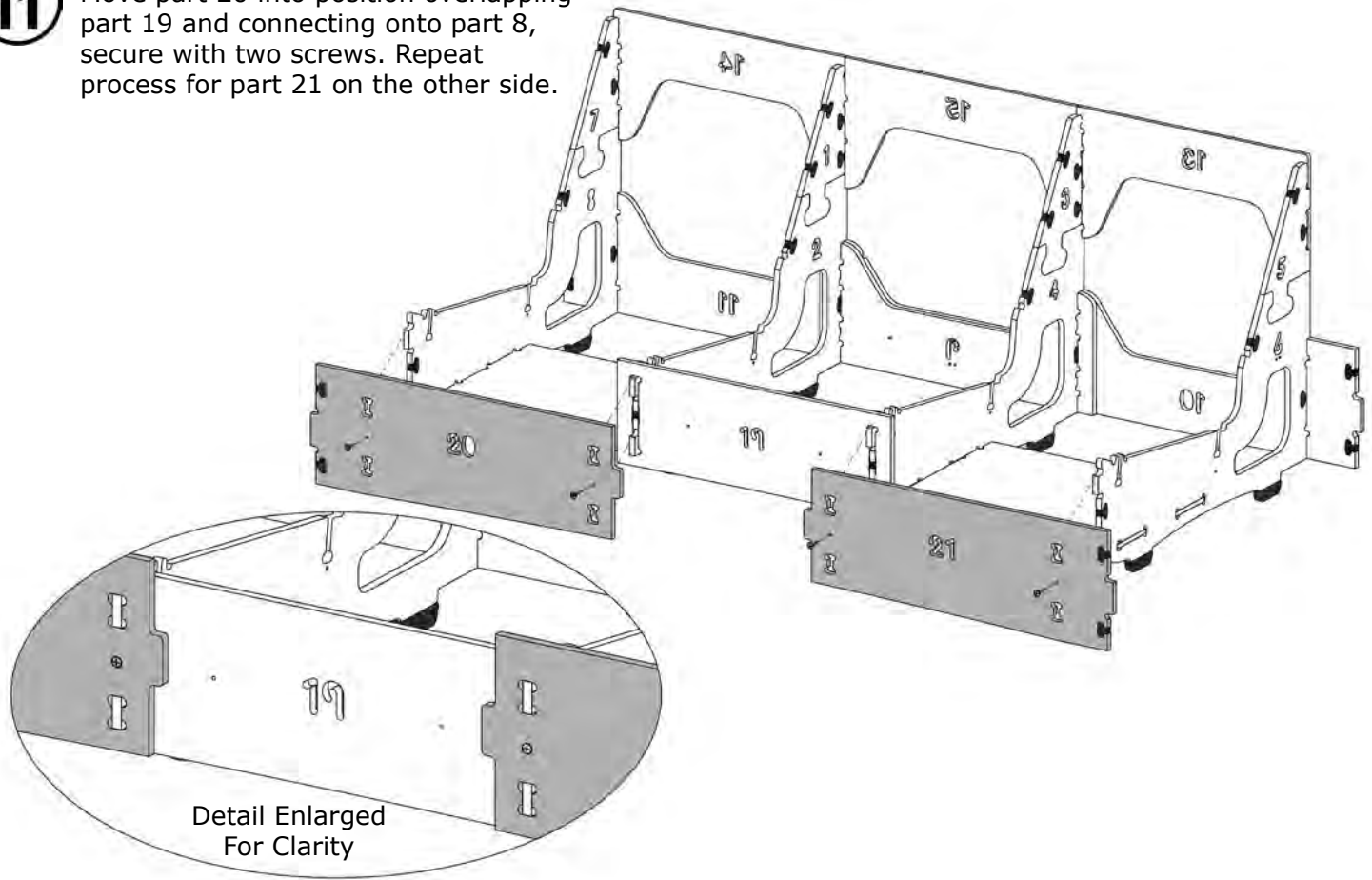

**12**

Align part 22 over part 19 and secure with two of the special size screws. (The special size screws for this step are in a small plastic bag labelled "For use with parts #12 and #22". These screws are slightly smaller so that they don't protrude.)

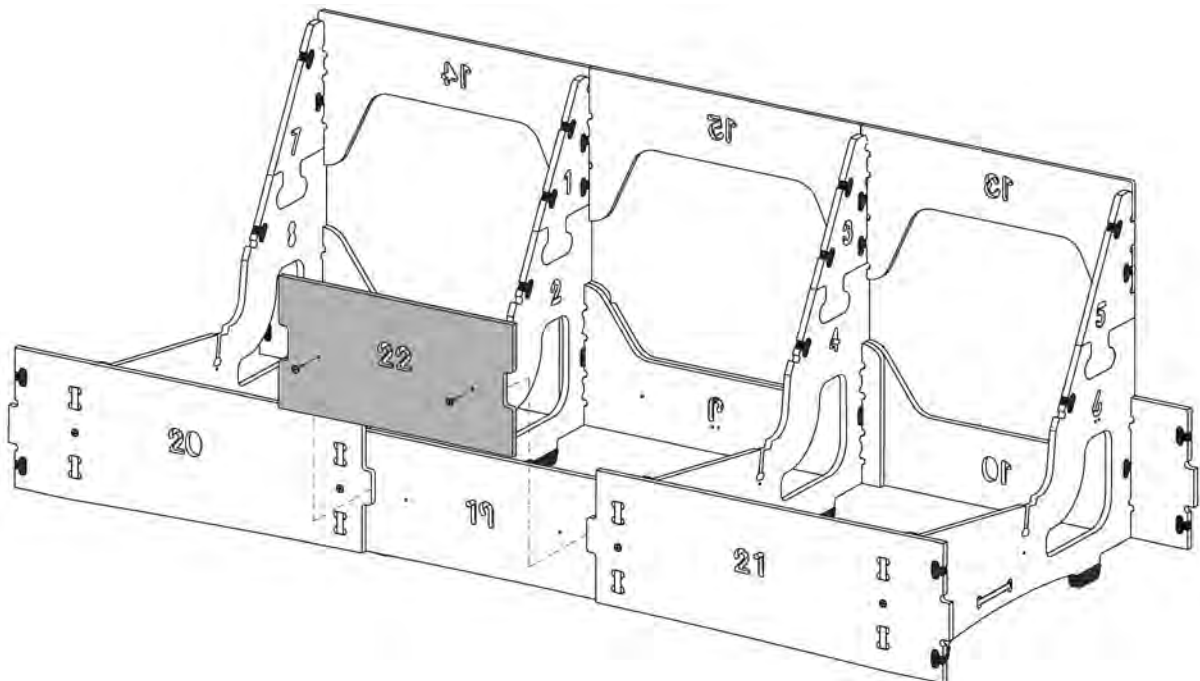

- 13** Slide part 23 into the rear slots of part 8 and 2 and secure with two screws. Slide part 24 into the rear slots of part 4 and 6 and secure with two screws. Part 25 slides down into position between 23 & 24.

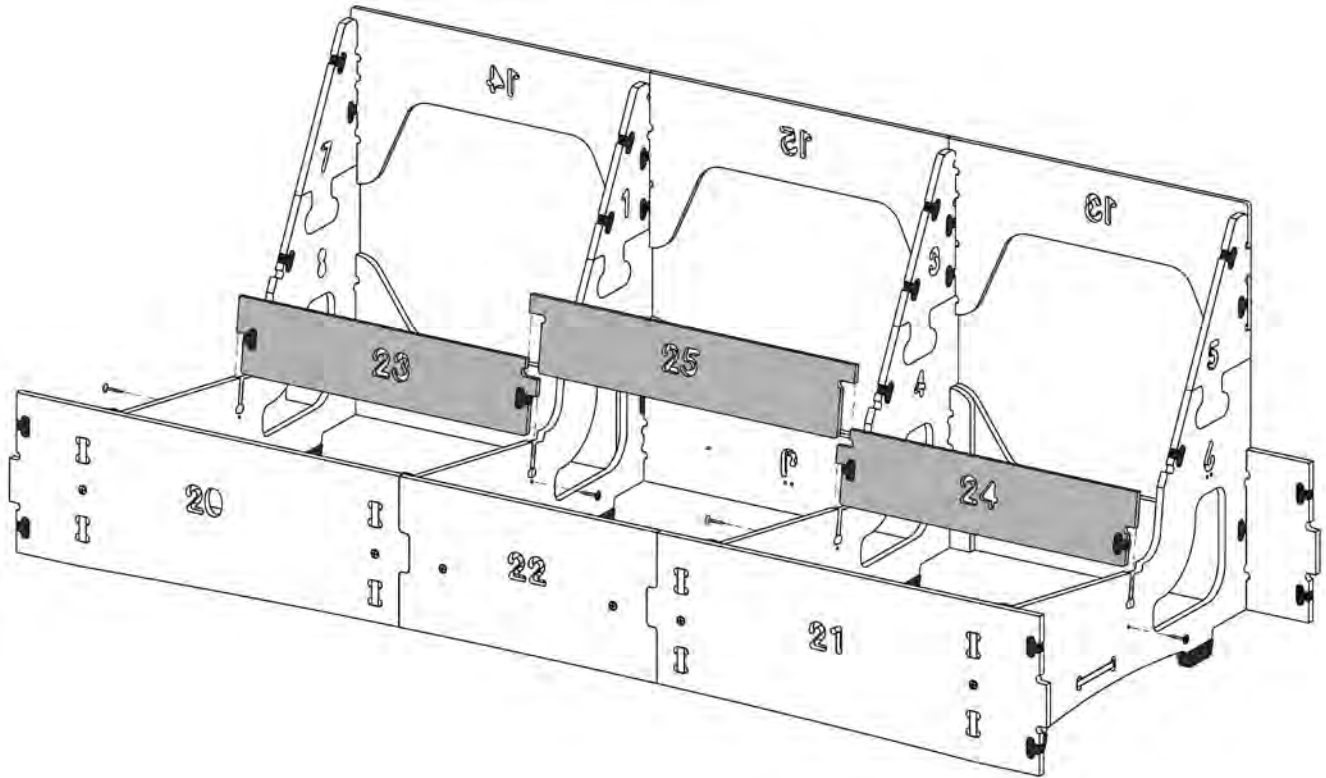

- 14** Work from left to right sliding parts 26, 27, and 28 into the slots near front of frame.

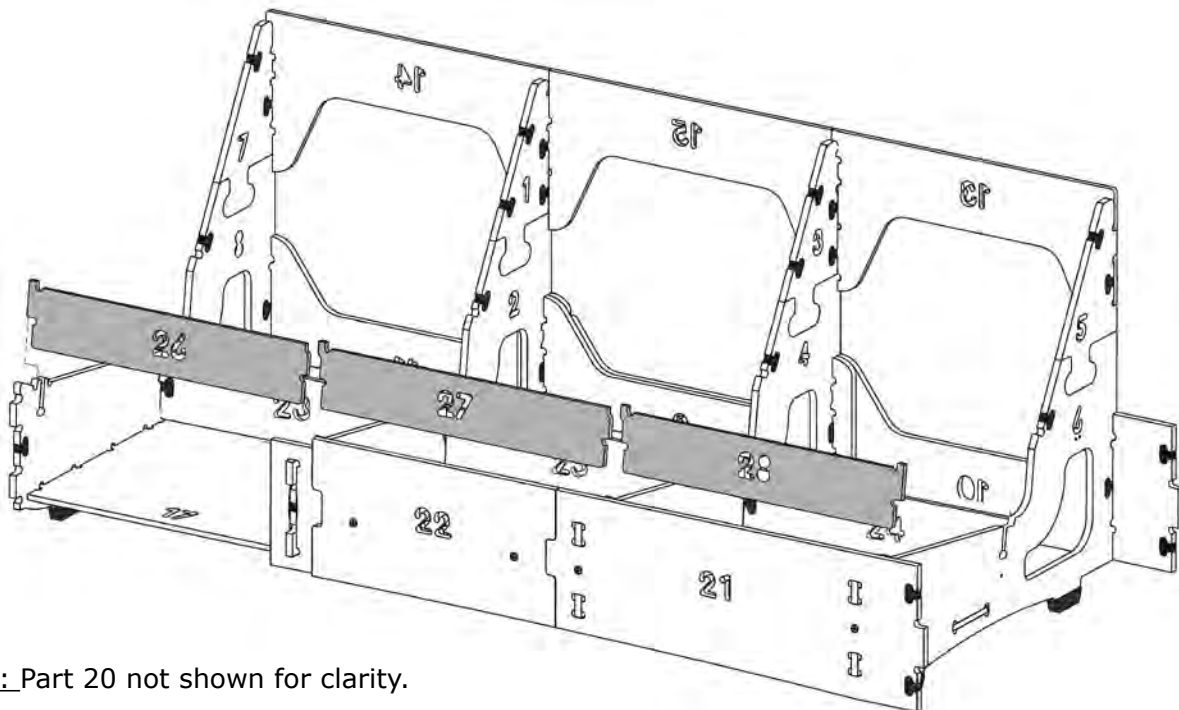

NOTE: Part 20 not shown for clarity.

- 15** Move part 29 into position and secure with four screws. Repeat for part 30. Move part 31 into position between 29 and 30 then secure with two screws.

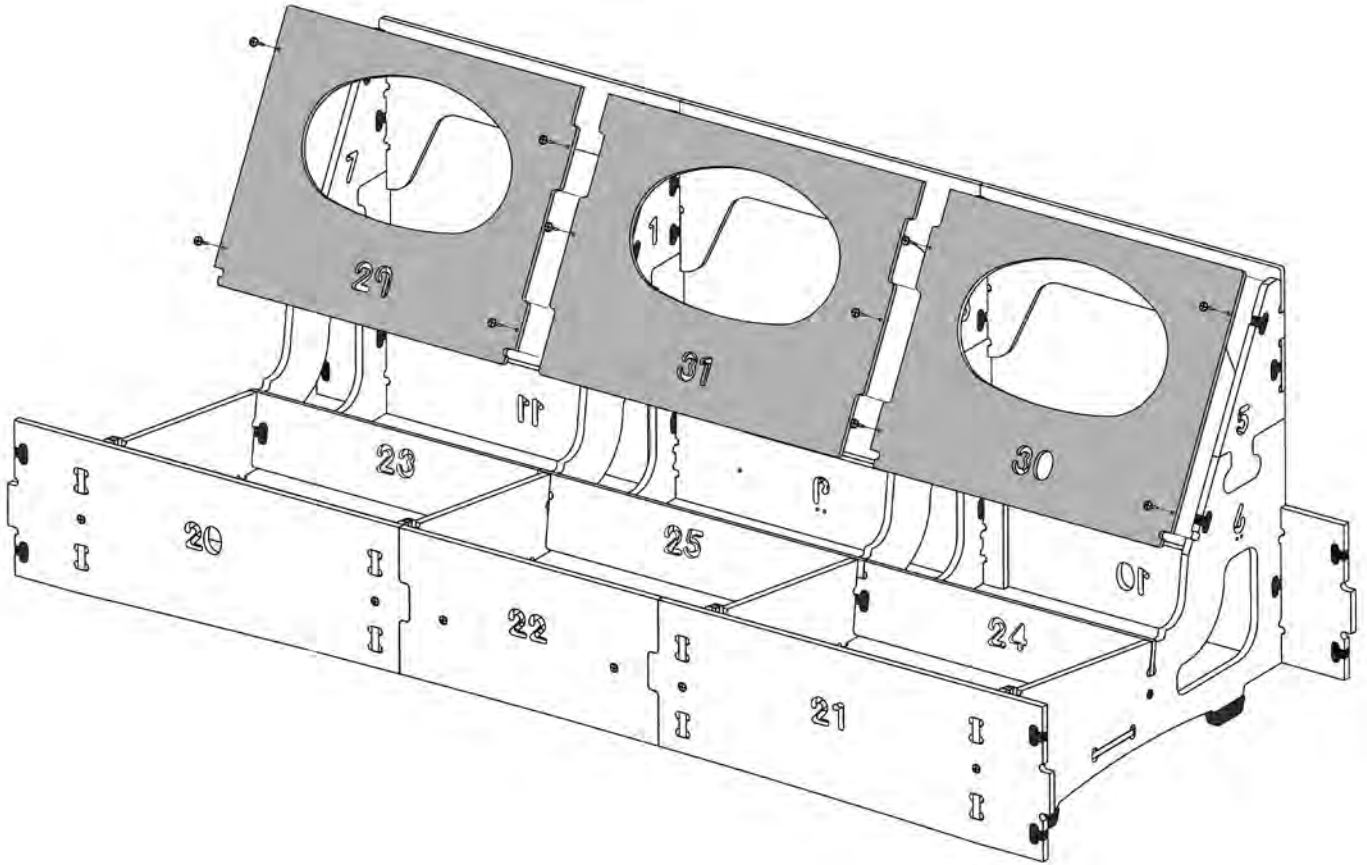

- 16** Move part 32 into position at end of frame and secure with four screws. Repeat process for part 33 on the other end.

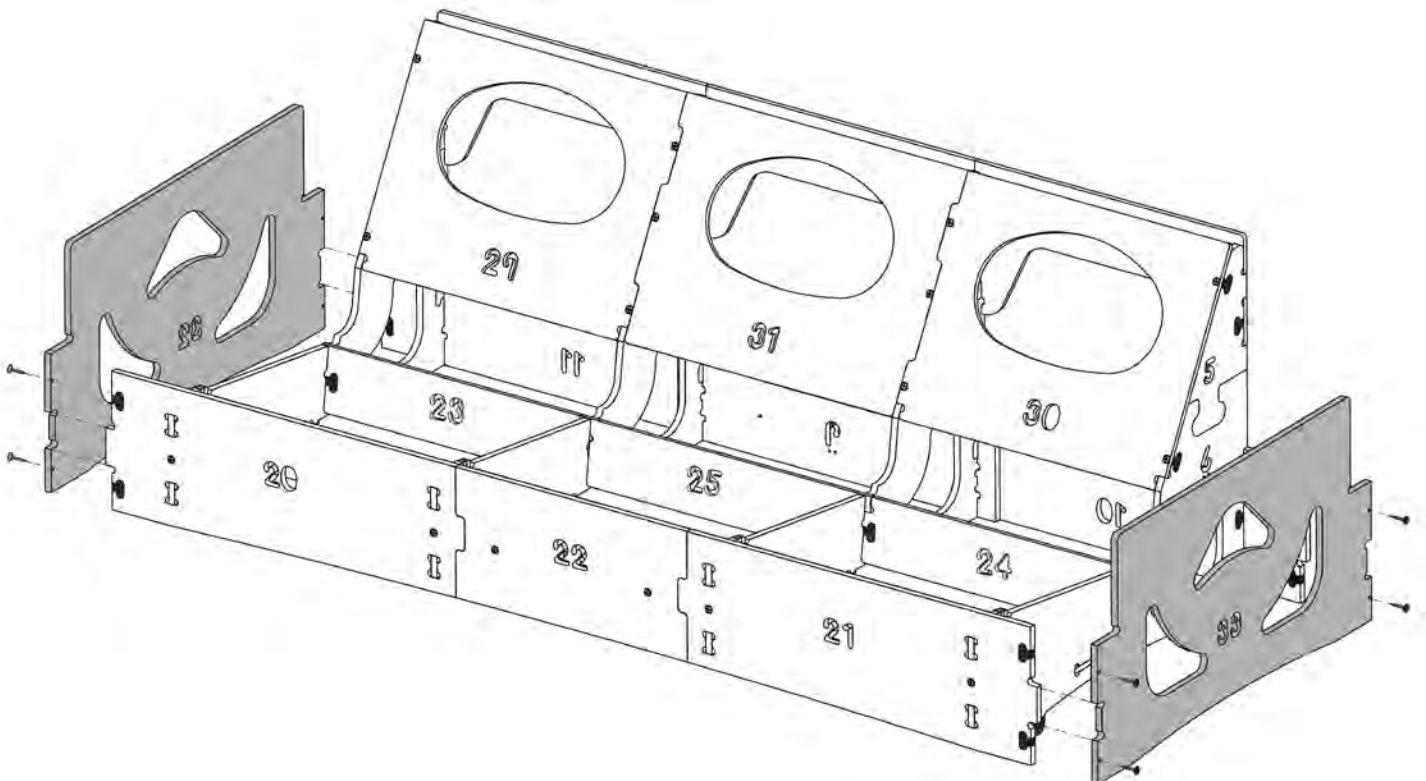

- 17** Move part 34 into position at left end of frame. Place parts 35 and 36 as shown. Reference "Top View" to see correct position.

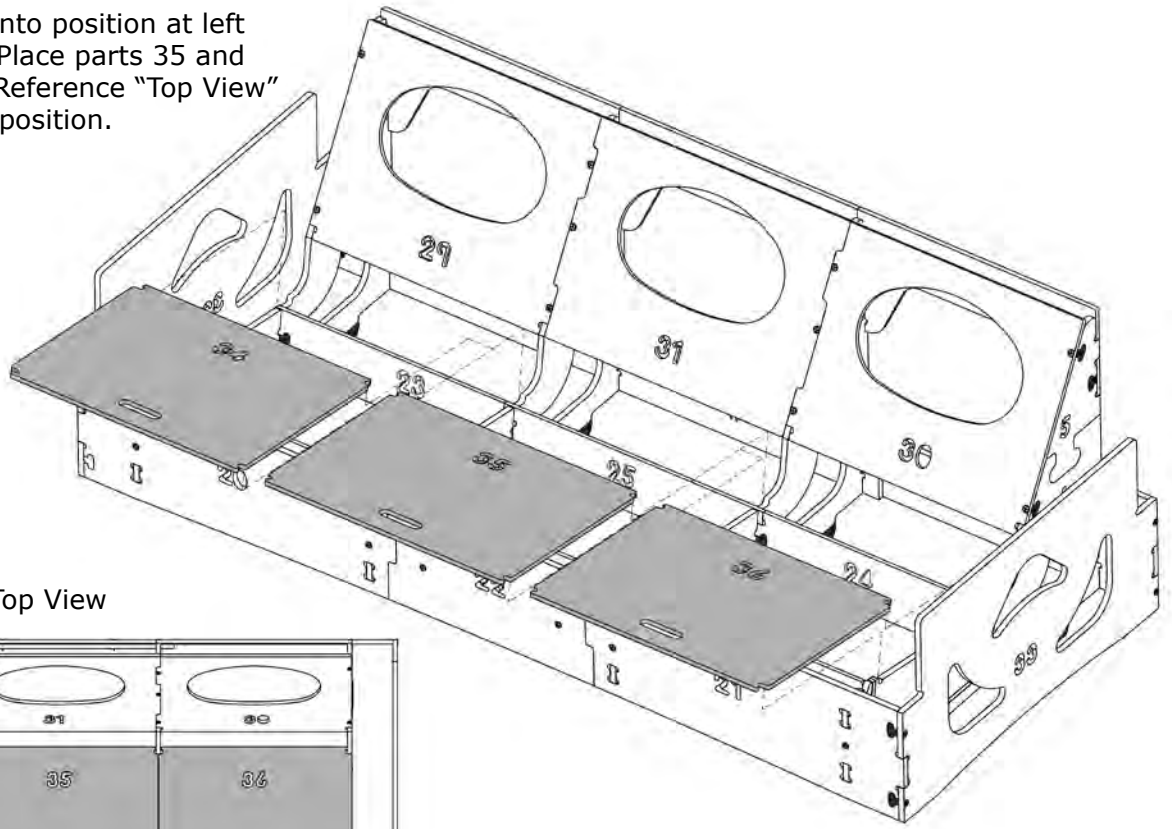

Top View

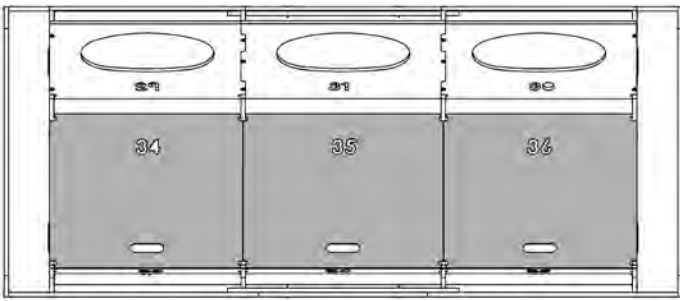

- 18** This completes the frame assembly of your sofa! You will have two pieces of wood left, parts 37 and 38. They will be used later during fabric assembly.

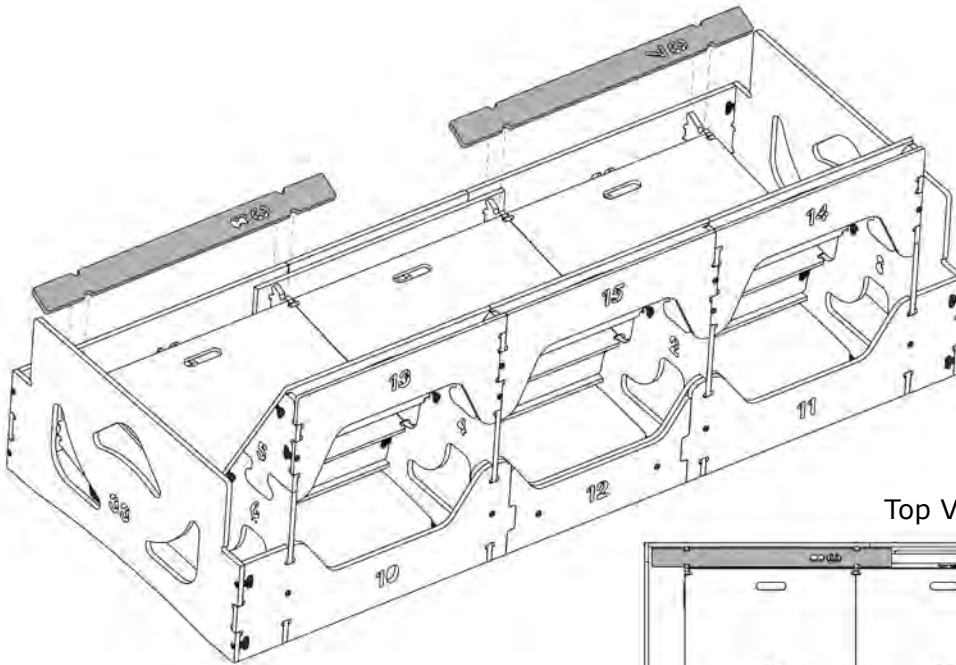

Top View

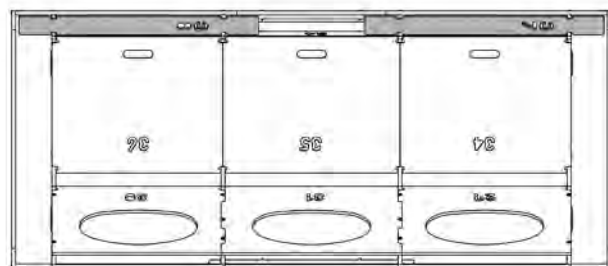

# Fabric & Foam Assembly

Most of the fabric covers come inside out. (It is the way they are sewn and protects the fabric surface in shipping.) Unfold them all in preparation for assembly. To unfold a piece with a zipper just pull the zipper apart as shown in the picture to the right.



You can snip off any loose hanging threads from any of the covers. They are left long during automatic trimming in the sewing process. Snipping them won't affect the strength of the seams.

Beauty tips: In addition to these printed instructions you may want to watch our beauty tips videos on the customer service page of the website. The videos show demonstrations on how to apply the fabric covers and make them look smooth and wrinkle-free.

## Fabrics



Frame Back Cover (1)



Seat Cushion Cover (2)



Back Cushion Cover (2)



Arm Cover (2)



Arm Panel Cover (2)



Frame Front Cover (1)



Elite Fabric (2)

## Foam



Seat Cushion (2)



Top Rail Piece (3)



Back Cushion (2)



Arm Foam (2)

- 1** Take the three Top Rail pieces and place them on the top of the frame. Push them down into position between the front and back wood pieces.

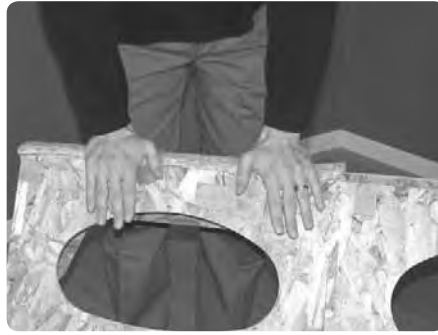

- 2** Take an Arm Panel Cover and slide it over part #32. Be sure the top part of the cover is unfolded. If it isn't, the cover will hang on the wrong side of the frame.



- 3** Take the other Arm Panel Cover and slide it over part #33. Be sure the top part of the cover is unfolded. If it isn't, the cover will hang on the wrong side of the frame.



- 4** Now take the Frame Back cover (its the largest fabric piece) and place it over the back of your frame as shown.



5



Locate wood parts 37 and 38. Slide one of the wood pieces into the sleeve sewn into the Front Cover.



Slide the wood all the way in until it reaches the end of the sleeve. (Use the sanding block if the wood doesn't slide smoothly.)



Slide the other wood part into the other side of the sleeve. It may be helpful to kneel on the cover to keep it from moving.



Place the cover down into position on both sides of the frame to form the front edge.



The cover is cut away in this photo to show how the notches in wood parts 37 & 38 should be positioned onto the sofa frame.



Press very firmly to settle and secure the front edge assembly down onto the frame and into the notches.

6

Now you can fasten the velcro closures at the front and back of the frame.

Front



Back



**7** Cover the two arm foams with the elite fabrics. The elite is a white silky material that will help the Arm cover slide over the foam. Wrap the foam smoothly and stuff the edges into the slot as shown. Make sure all of the foam is covered or the cover in step 8 will not slide smoothly into position.



**8** Take the Arm Covers and the elite covered arm foams and follow the sequence below.



Find the square corner of the arm cover and the square corner of the arm foam.

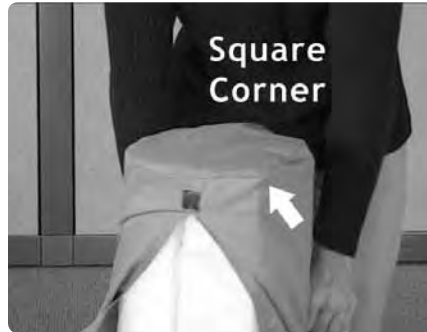

Put the cover over the end of the foam, aligning the square corners.



Then turn the arm over and smash the foam down so that you can slip the foam inside the other end of the cover. It helps to stand in order to use your weight to smash the foam down.



When you release the smashed foam...



...it will spring into position inside the cover.



Make adjustments to get it all straightened out.



Velcro the 2 flaps together...



...and push them into the groove on the bottom of the arm.



Place the arms onto the frame and slide them down into position. The square corner goes toward the inside of the frame.



The frame goes up into the slot on the underside of the arms.

**9**

Find the Seat Cushion Covers and Seat Cushion Foams and follow the sequence below.



Match the rounded front edge of the seat cushion foam with the rounded edge of the seat cushion cover.



Position the cover over the foam and align the corners of the foam cushion with the corner seams of the cushion cover.



You can stick your hand right up in there to get everything smooth.



Working your way around the sides of the cushion pull the corners of the cover onto the foam...



...and zip up the cover.



Place the seat cushion on the frame. The rounded edge of the cushion goes toward the front.

**10** Find the Back Cushion Covers and the dacron filled Back Cushions and follow the sequence below.



When filling the back cushion, match up the rounded corners of the back cushion with the rounded corners of the cover.



Push the filler into the cover. You can reach way up in there to fill out the corners.



Zip up the cushion.



You can knead the cushion on the floor to straighten and smooth it out.



You can further straighten and smooth the back cushion by striking it on the floor with several good whoops.



Change ends of the cushion and repeat.



This is also the way you can "fluff" the cushions in the future.



Place the back cushions on the frame.



Congratulations, assembly is now complete.



#### **SEAT DEPTH ADJUSTMENT**

The furniture is designed to allow for seat depth adjustments. The normal setting for the cushions to protrude is 1½" out in front of the frame. Slide the seat cushion in or out to adjust to your own seat depth preference.



#### **REMEMBER**

You can snip off any hanging threads from the covers. They are left long during automatic trimming in the sewing process. Snipping them won't affect the strength of the seams.

# HOME | RESERVE

Home Reserve products are  
made in the USA under patents:

#6,267,446

#6,568,058

#6,981,747

#7,044,557

#7,523,989

