



Brook sofa

assembly instructions





Smooth & Wrinkle-Free Fabric Covers:

In addition to these printed instructions, you may want to watch our beauty tips videos on the customer service page of our website. The videos show demonstrations on how to apply the fabric covers and make them smooth and wrinkle free.



Renewability: Individual foam and fabric parts are available. You no longer have to worry that something will happen and you'll just have to live with it. From pet attacks to paint spills, it's easy to recover from a furniture accident.

CUSHIONS

Foam: The seat cushions will feel firm at first. That's intentional, since firmer foam lasts longer. You can shorten the break-in period by putting the cushions on the floor and walking on them for a few minutes.



Fabric Exchange: To use our 30-day fabric cover exchange program, contact us and we'll lead you through the process. Keep the covers out of actual use to preserve them in new, unused, and clean condition. Fold them neatly when repackaging to avoid wrinkles.

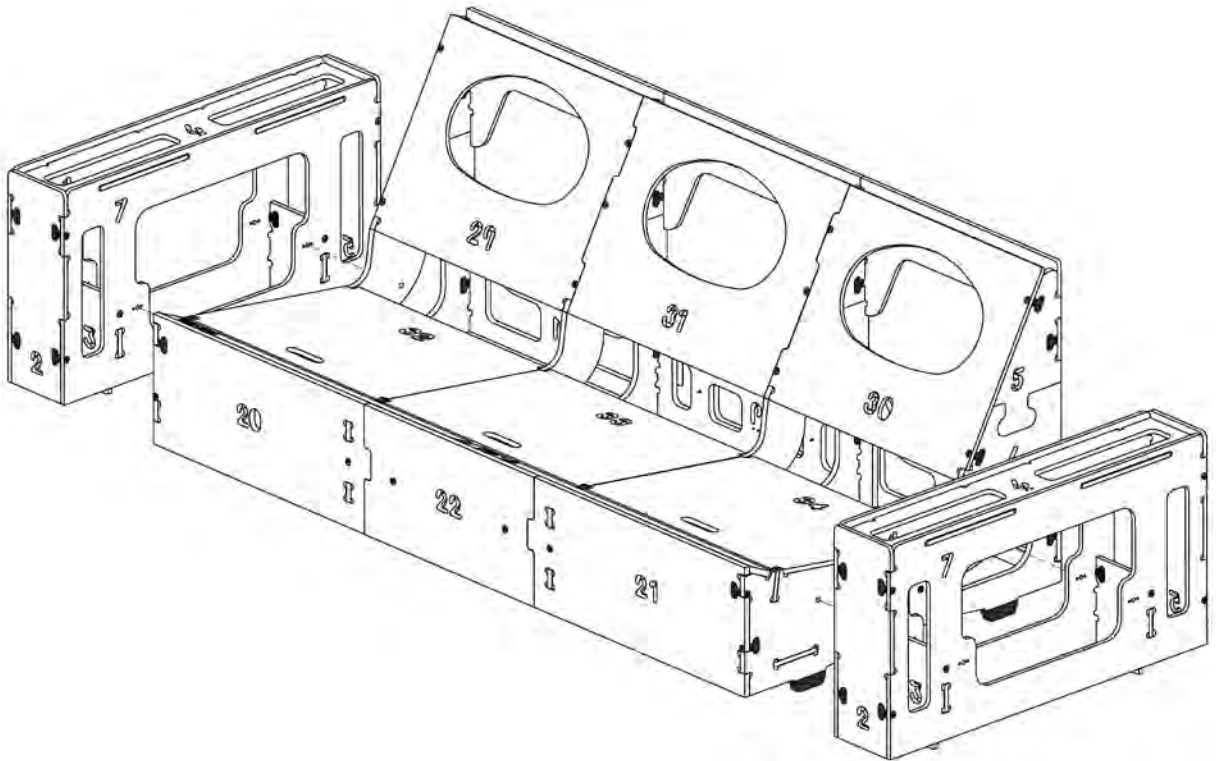

Tools needed: Phillips Screwdriver or powered drill with a Phillips screwdriver bit.

A sanding pad is included in case you wish to smooth over any of the surfaces or edges after the frame is assembled. It is not necessary to sand any of the frame parts during assembly. No glue will be used during assembly. Item will be ready for use immediately.

Arm Assembly

Open the boxes and set aside the foam and fabric for later. Leave the wood parts in the boxes, we will take them out as needed.

- 1** Take wood parts 1-7 out of box #1. Open the parts bag and insert the black plastic T-connectors into the parts shown here. Throughout these instructions it is okay to use a hammer to tap the T-connectors and wood parts into position.

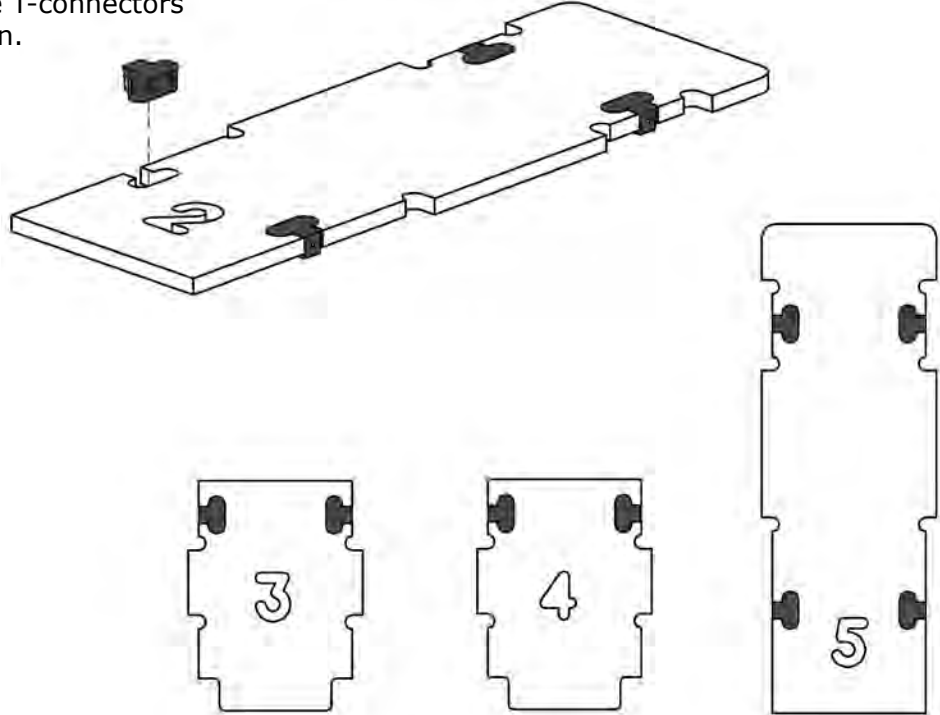

- 2** Connect parts 1 and 2 together and secure with two screws.

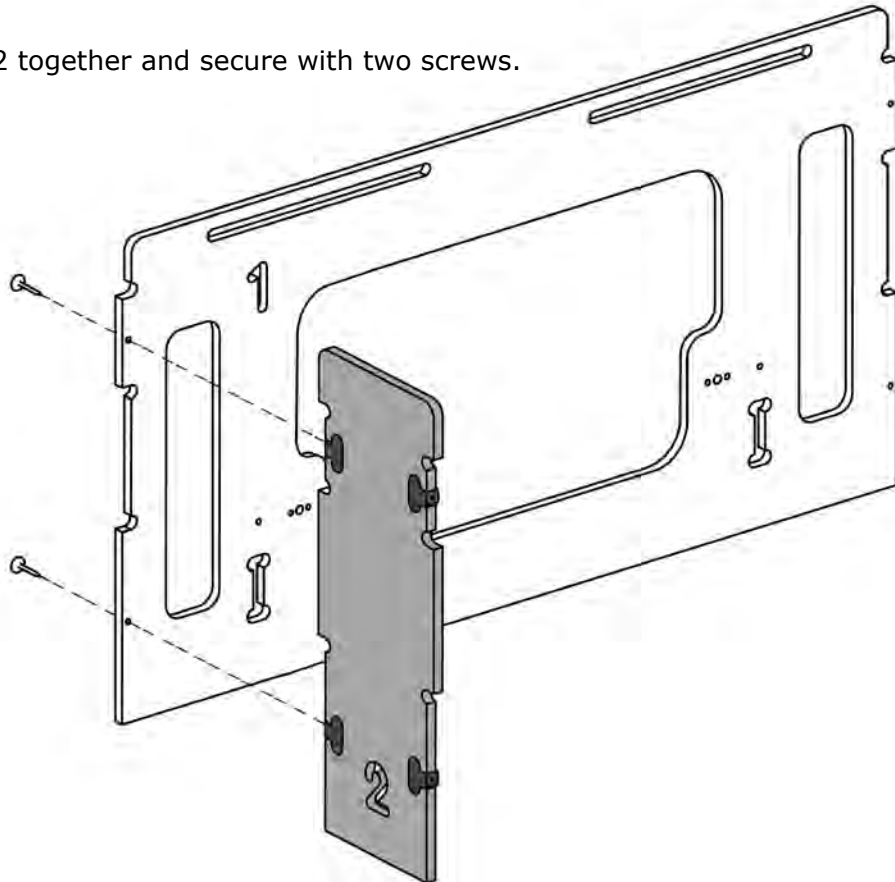

- 3** Place part 3 into position on part 1 and secure with a screw.

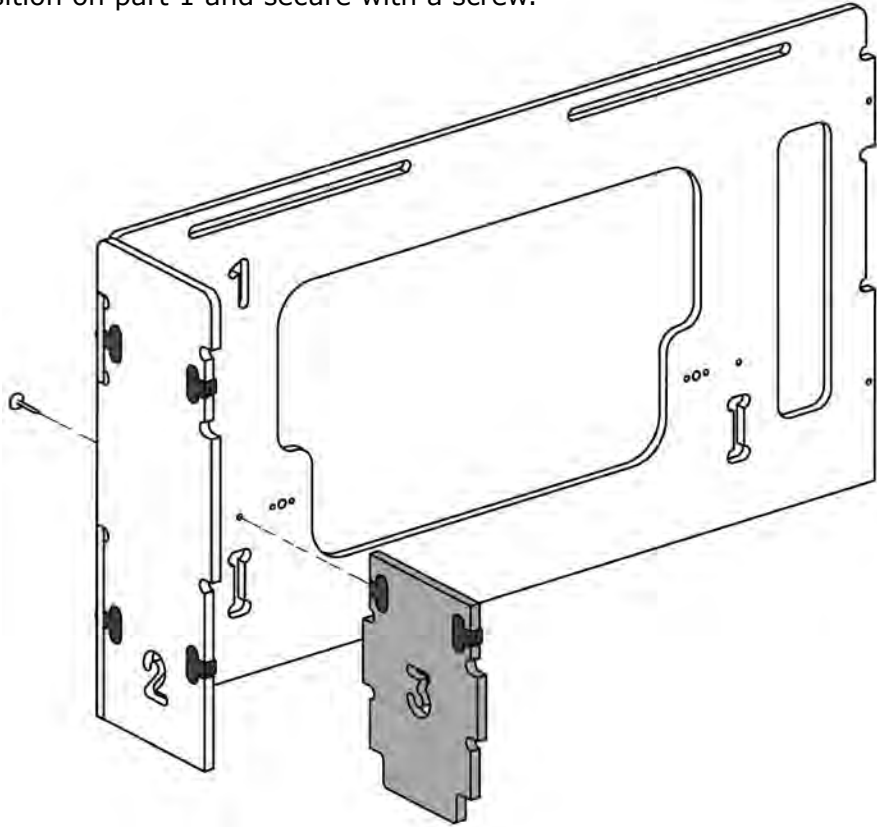

- 4** Place part 4 into position on part 1 and secure with a screw.

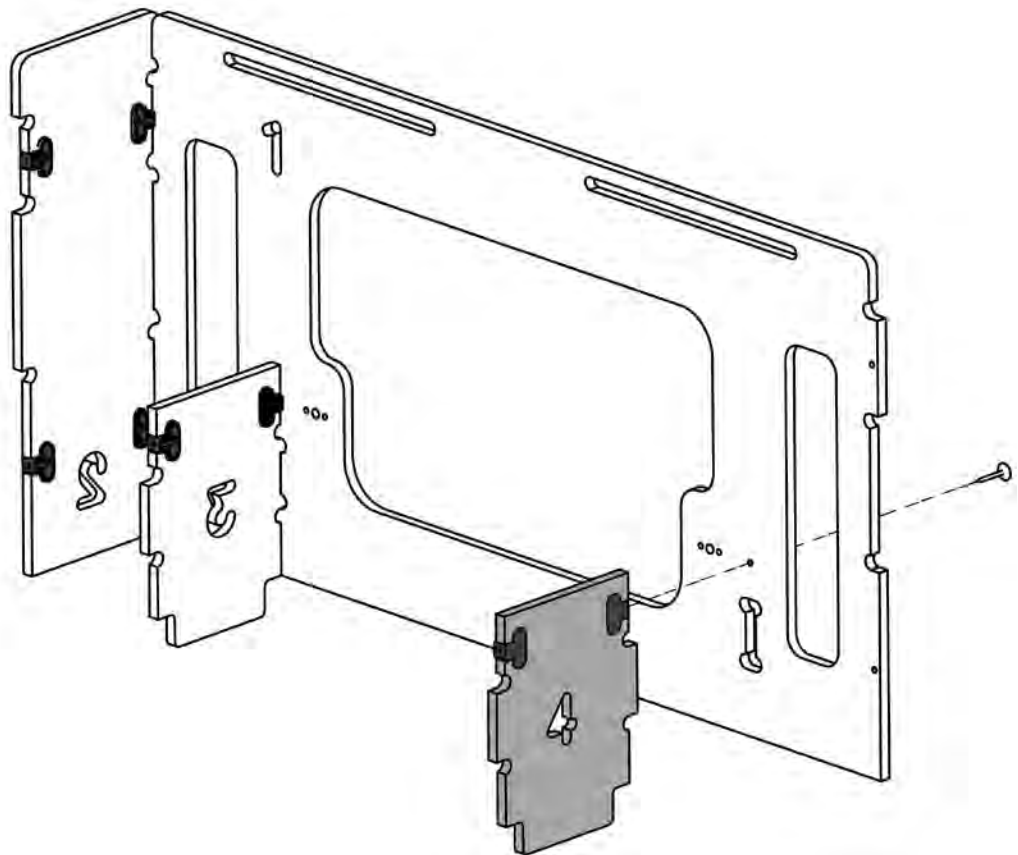

5

Connect parts 5 and 1 together and secure with two screws.

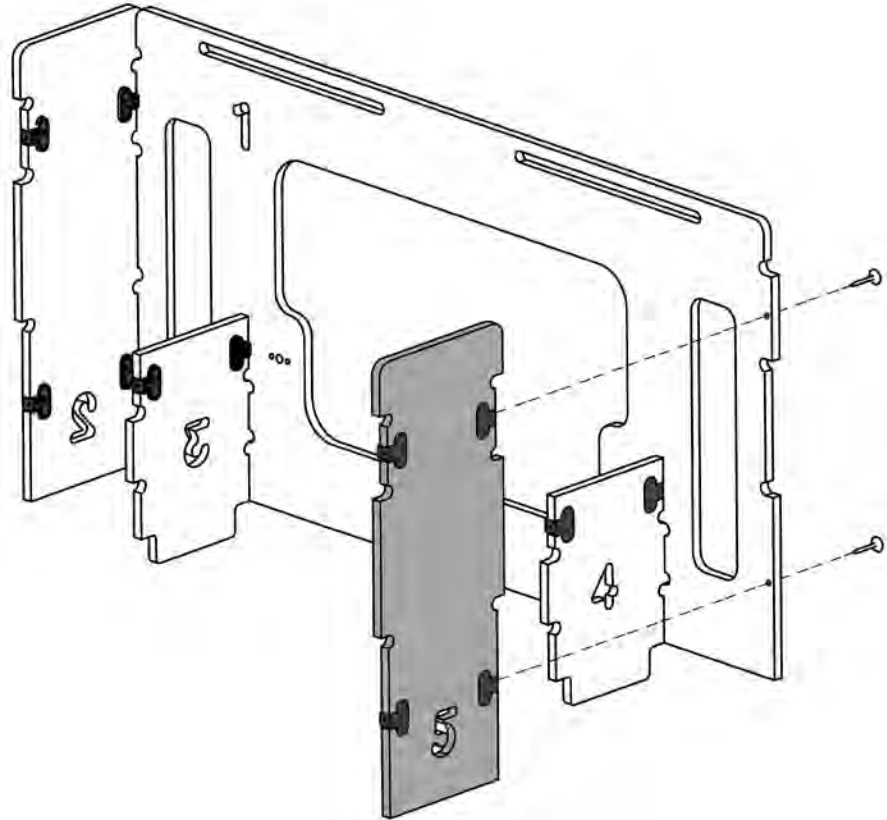

6

Place part 6 into position as shown.

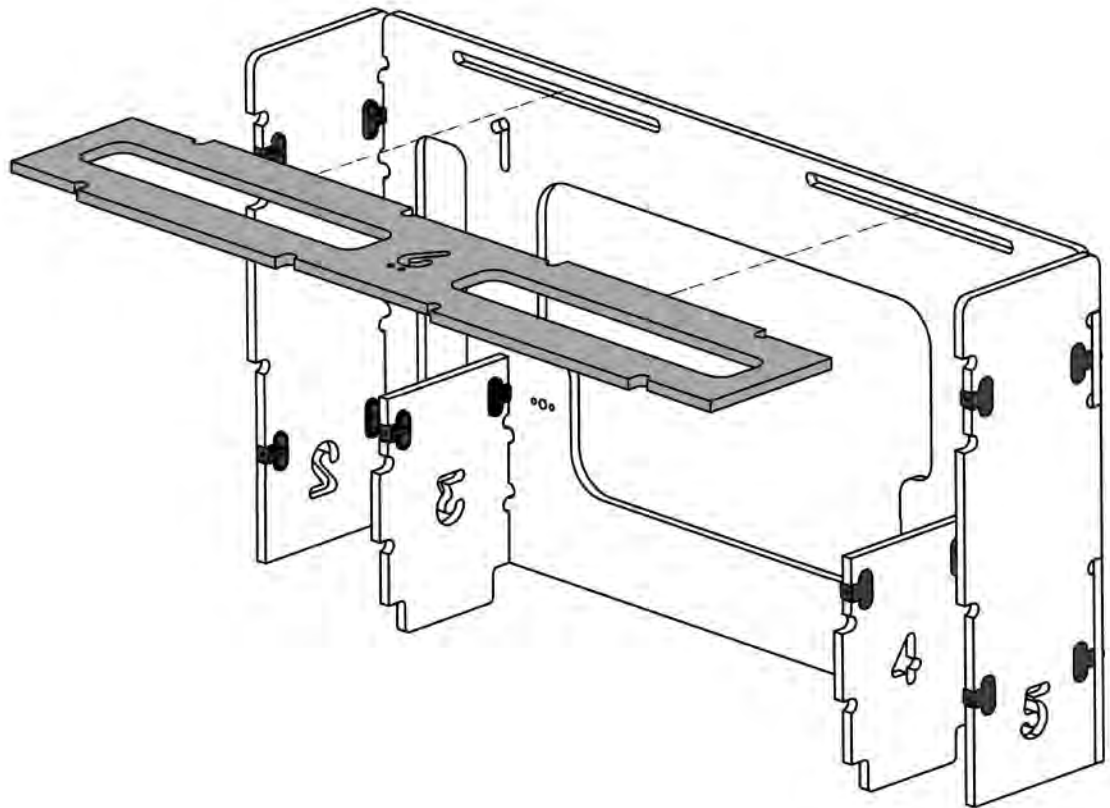

7

While holding part 6 in place, put part 7 into position on parts 2,3,4,5 and 6 and secure with six screws.

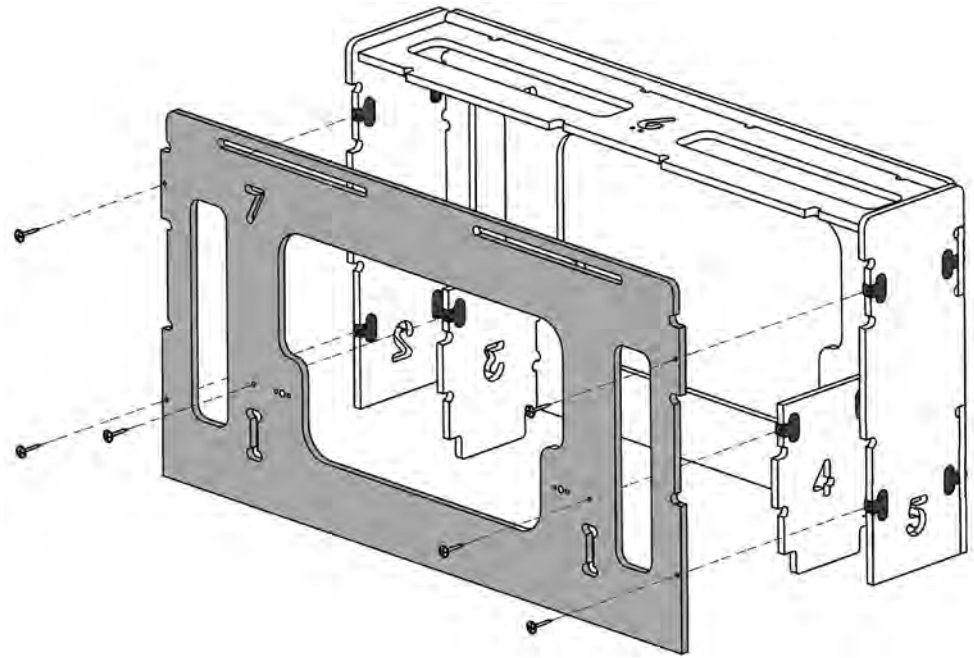

8

Repeat the process for assembly of the other arm. There will be another set of wood parts numbered 1-7. Take them out of the box and follow these same steps (1 - 7). Set the arms aside.

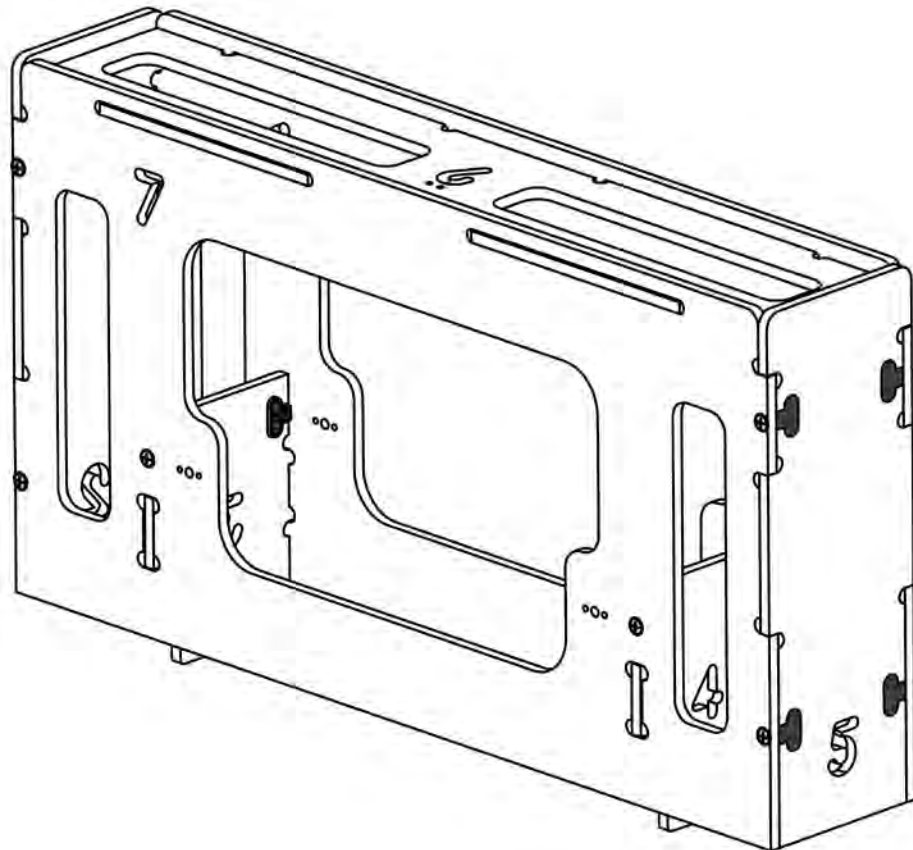

Frame Assembly

Now you can take all the remaining wood parts out of both boxes. These parts are not packed in order of assembly so don't worry about getting them mixed up. They are all numbered for easy reference.

- 1** Insert the black plastic T-connectors into the parts shown here. Throughout these instructions it's okay to use a hammer to tap the T-connectors and wood parts into position.

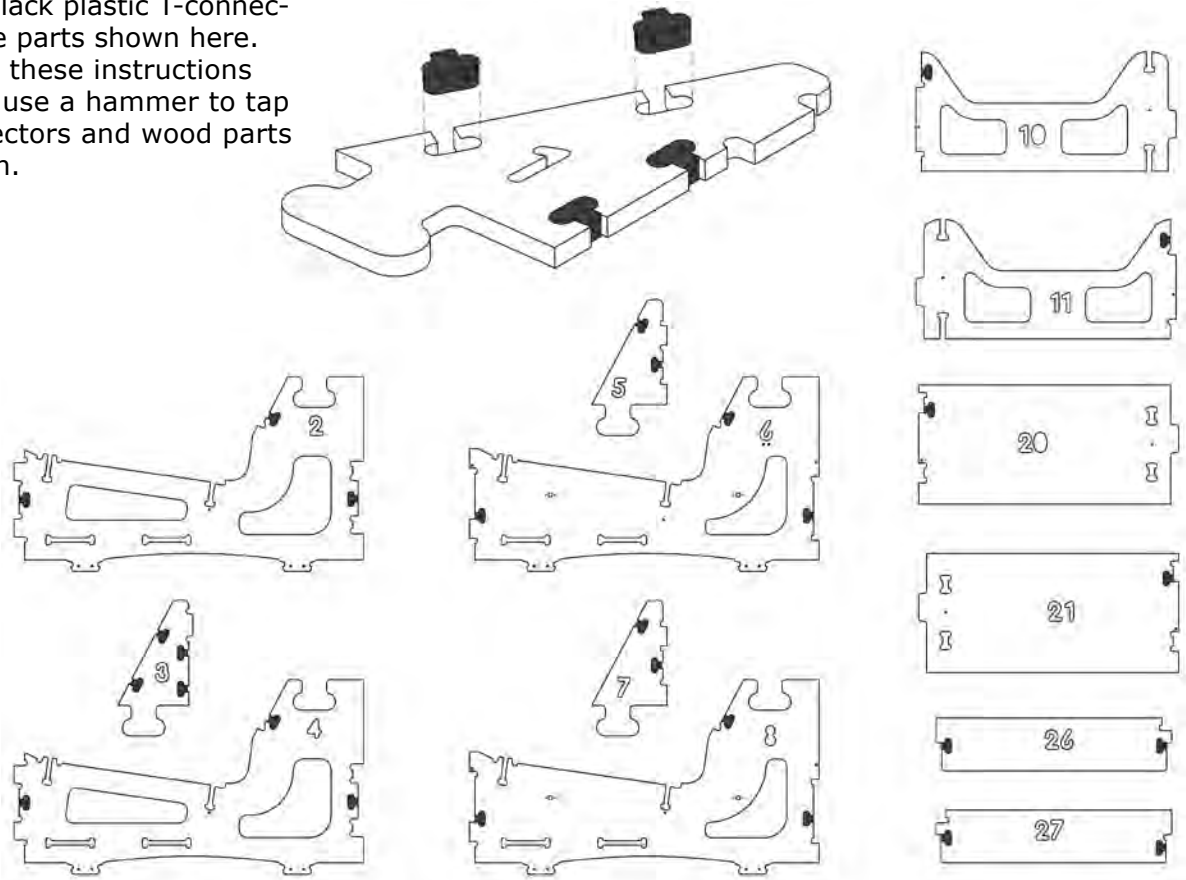

- 2** Attach black floor glides to the parts shown.

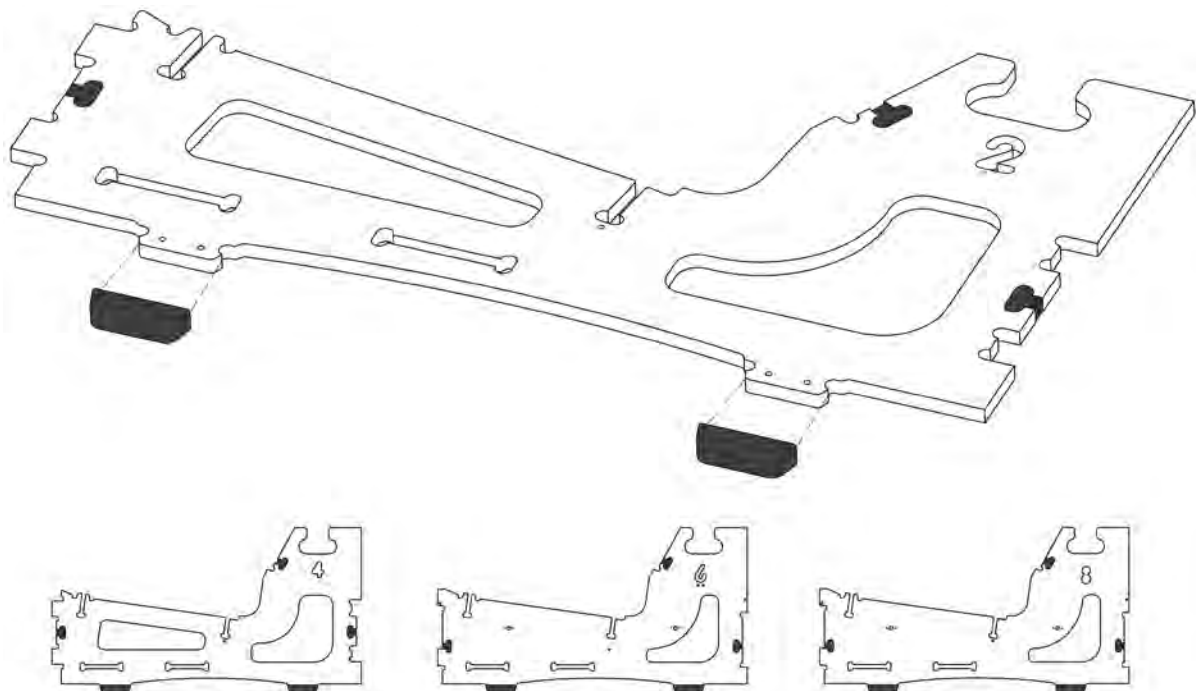

3

Connect parts 1 and 2 together. Repeat for parts 3 and 4, 5 and 6, 7 and 8.

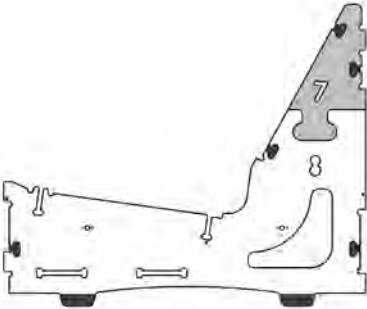
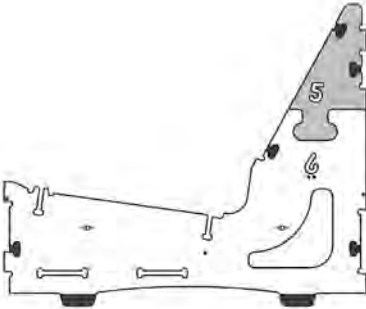
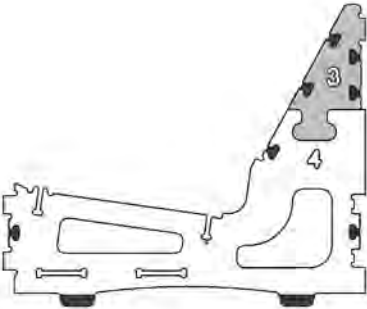
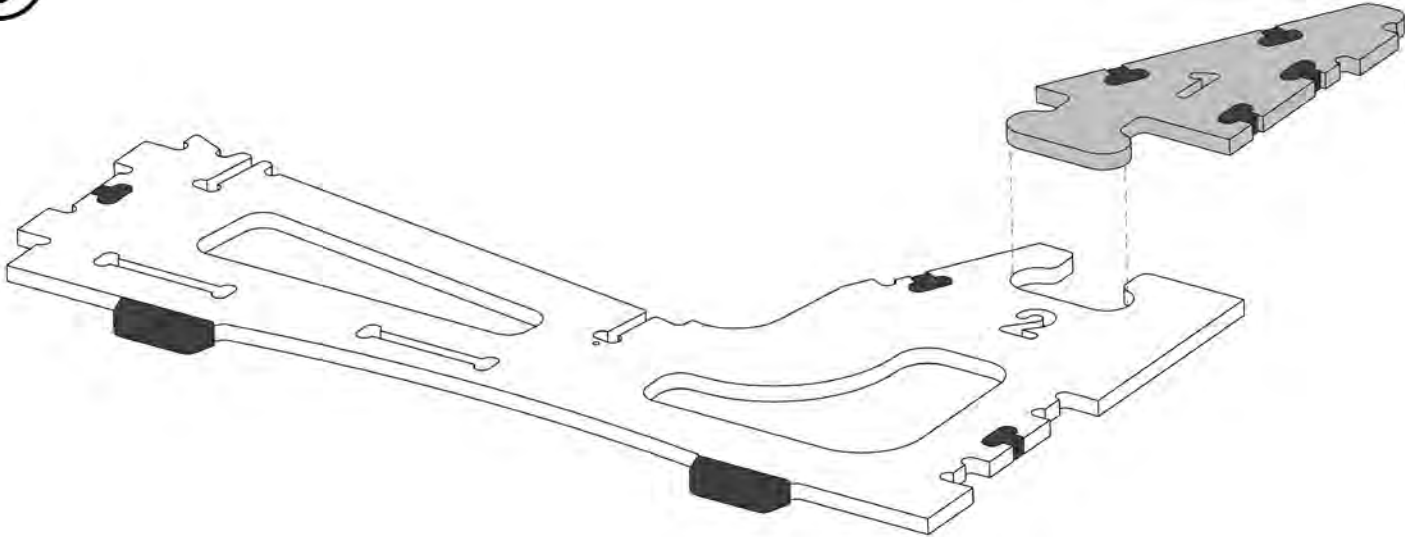

4

Slide part 9 onto parts 4 and 2. No screws are used in this step.

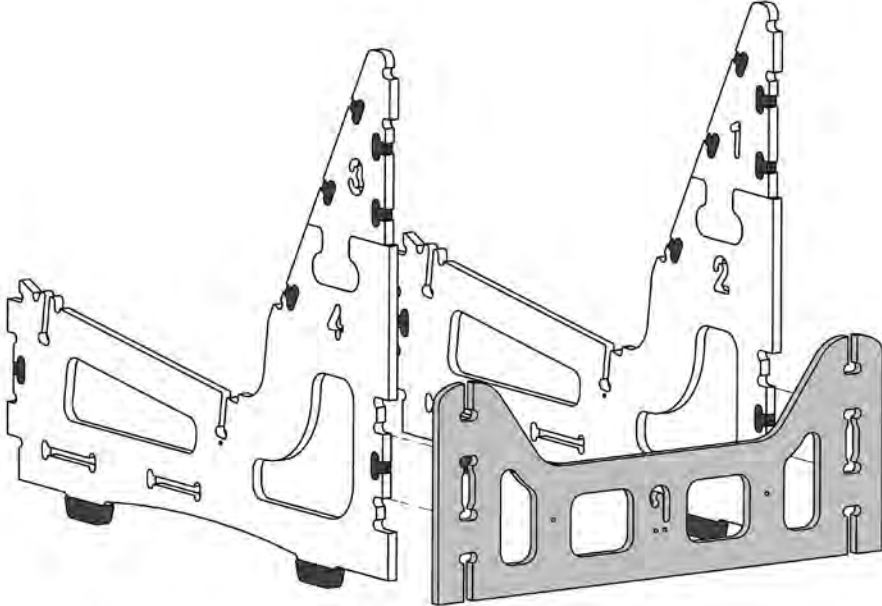

Detail Enlarged
For Clarity

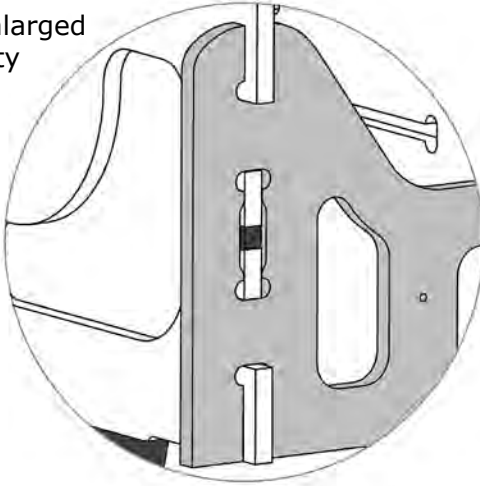

- 5** Move part 10 into position overlapping part 9 and secure with screw. (Make sure screw aligns with the hole in T-connector on part 4.) Move part 11 into position on the other side and secure with screw.

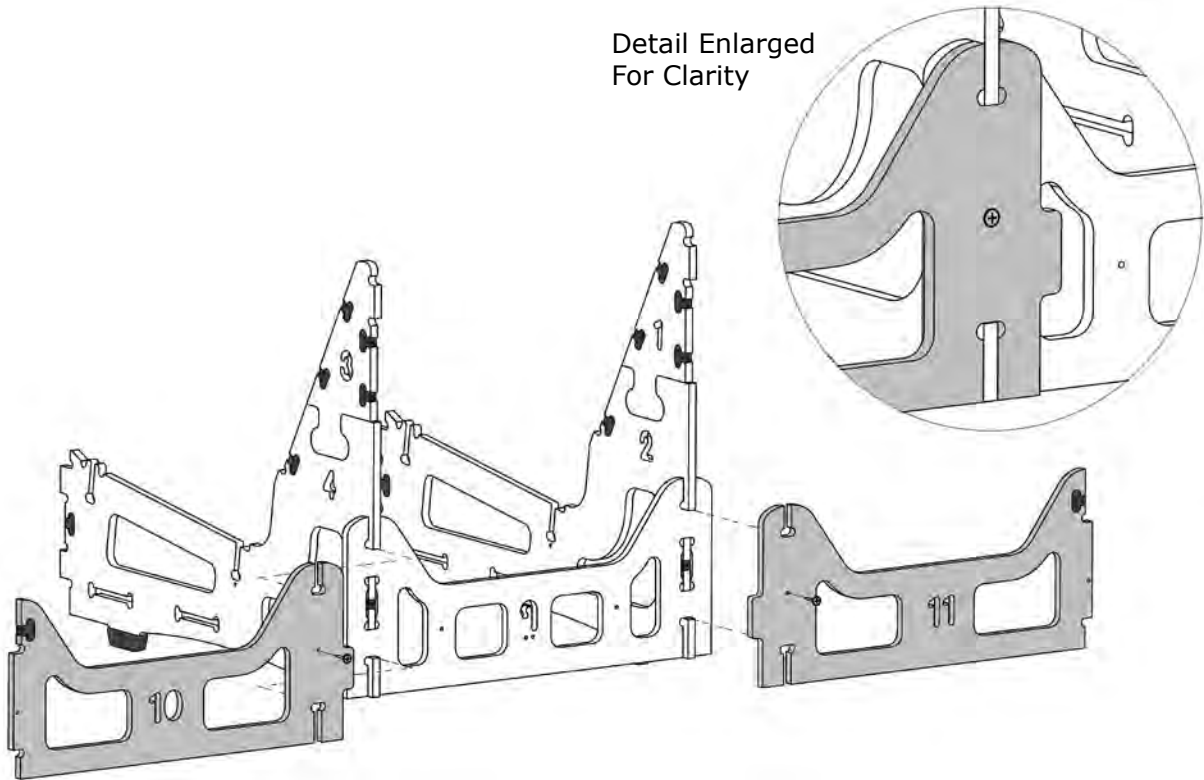

- 6** Align part 12 over part 9 and secure with two of the special size screws. (The special size screws for this step are in a small plastic bag labelled "For use with parts #12 and #22". These screws are slightly smaller so that they don't protrude.)

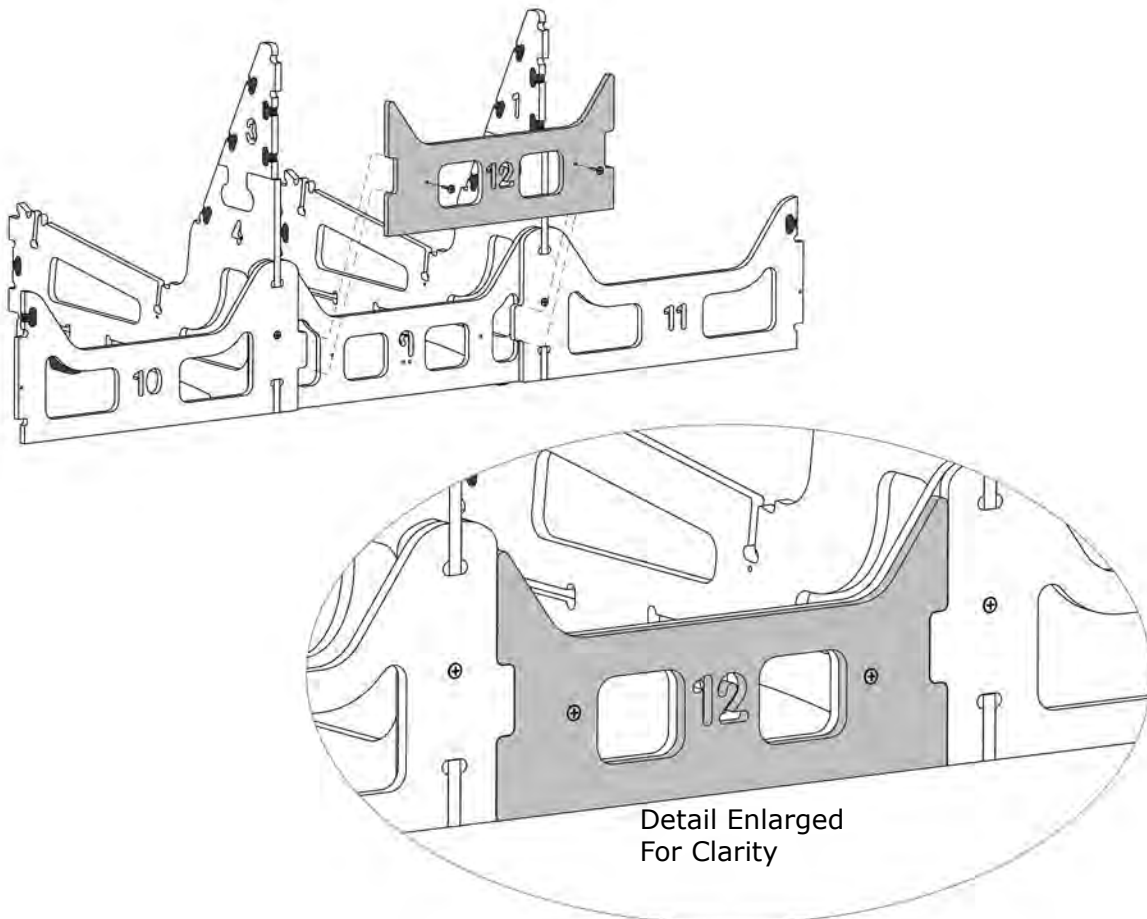

Detail Enlarged For Clarity

7

Slide part 6 into position on part 10 and secure with two screws as shown. Repeat the process for parts 8 and 11.

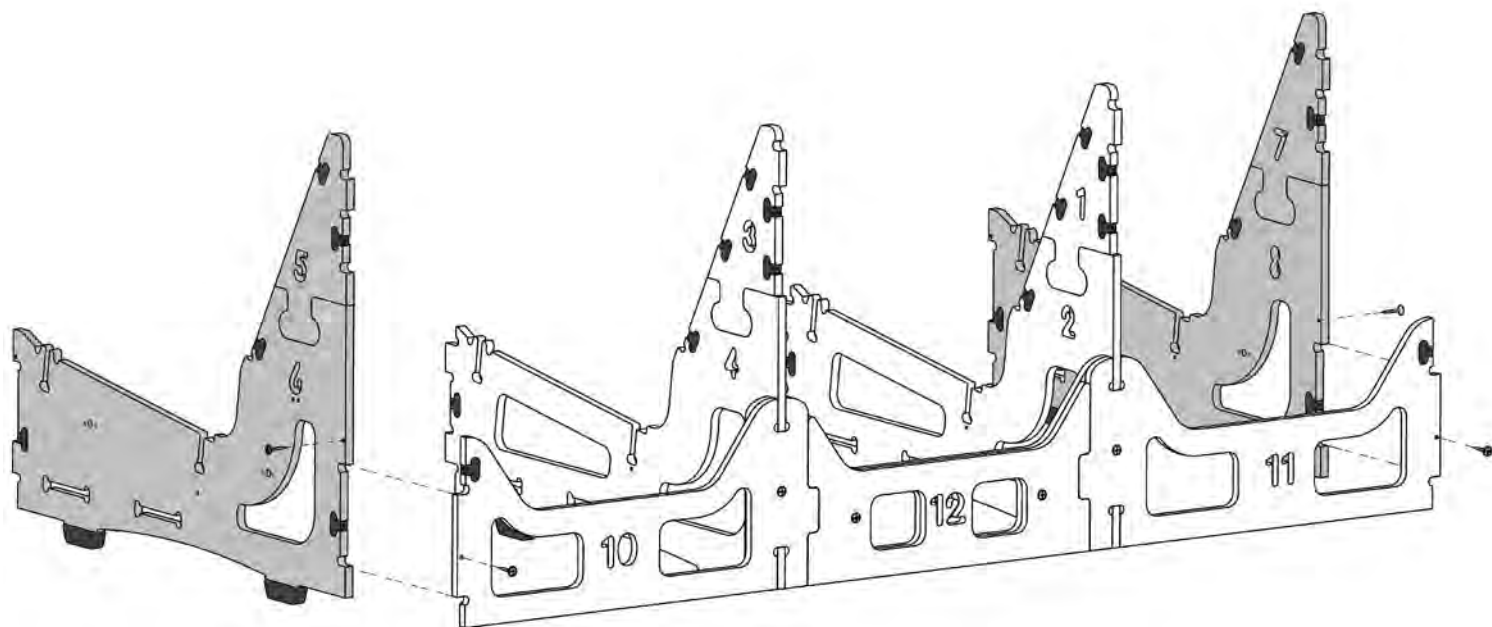

8

Align part 13 onto parts 5 and 3, secure with two screws. Align part 14 onto parts 1 and 7 and secure with two screws. Move part 15 into position between 13 and 14, secure with two screws.

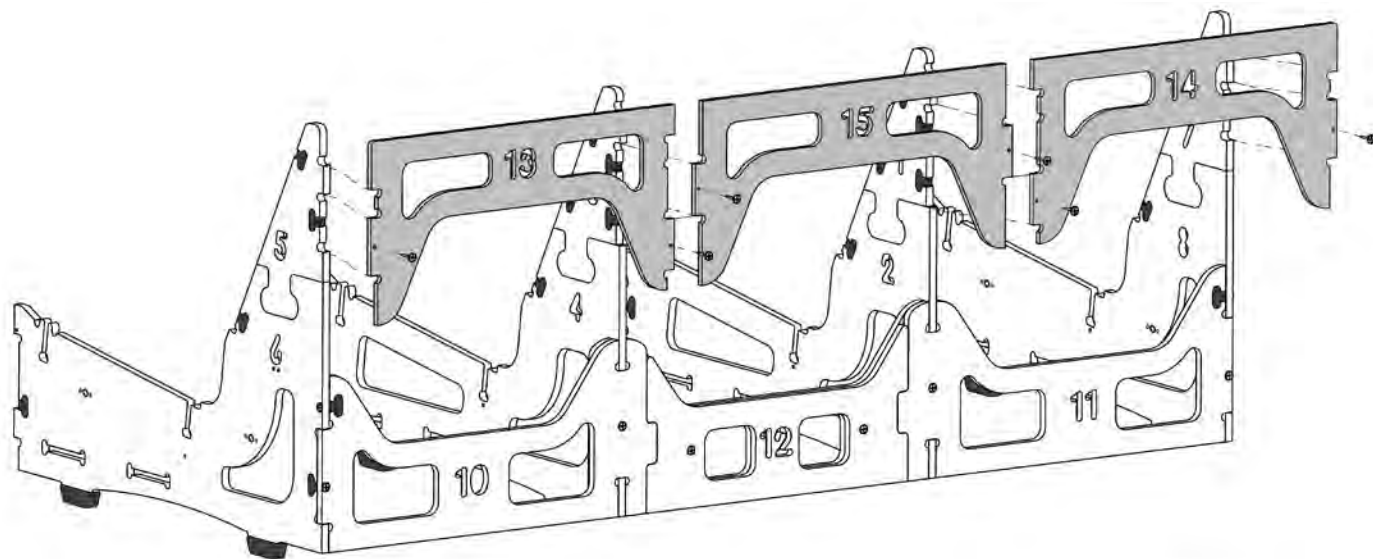

Detail Enlarged
For Clarity

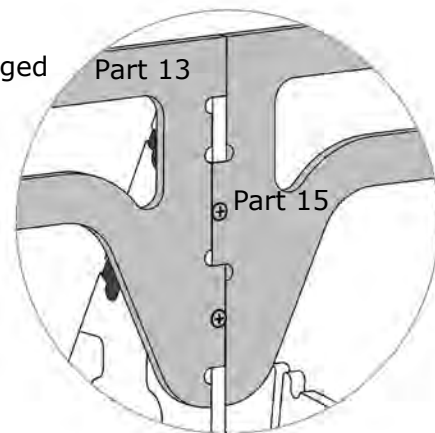

- 9** Spread parts 2 and 4 apart far enough to slide part 16 into slots on 2 and 4. (Refer to Top View A below.) Move part 8 out far enough to slide part 17 into the appropriate slots on 2 and 8. (Refer to Top View B below.) Follow the same procedure with part 18 on parts 4 and 6.

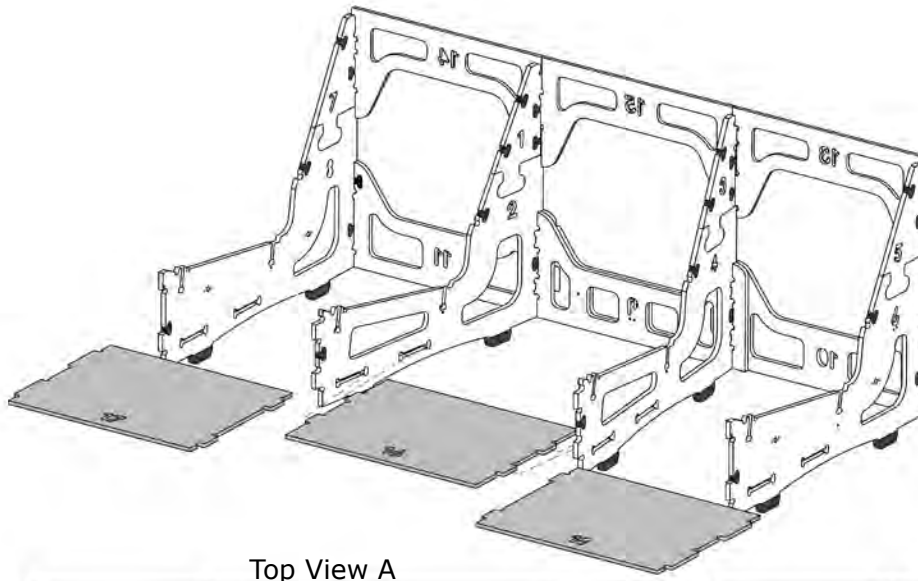

Top View A

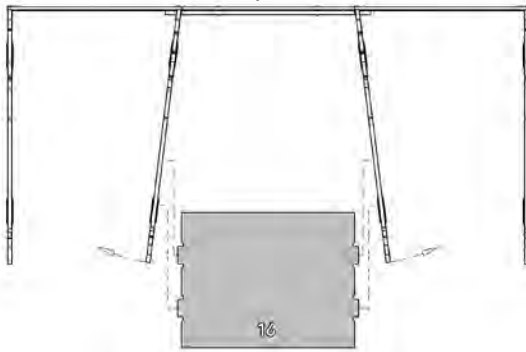

Top View B

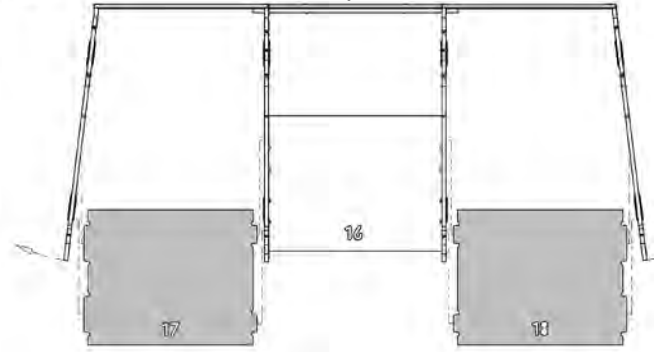

- 10** Slide part 19 onto parts 2 and 4. No screws are used in this step.

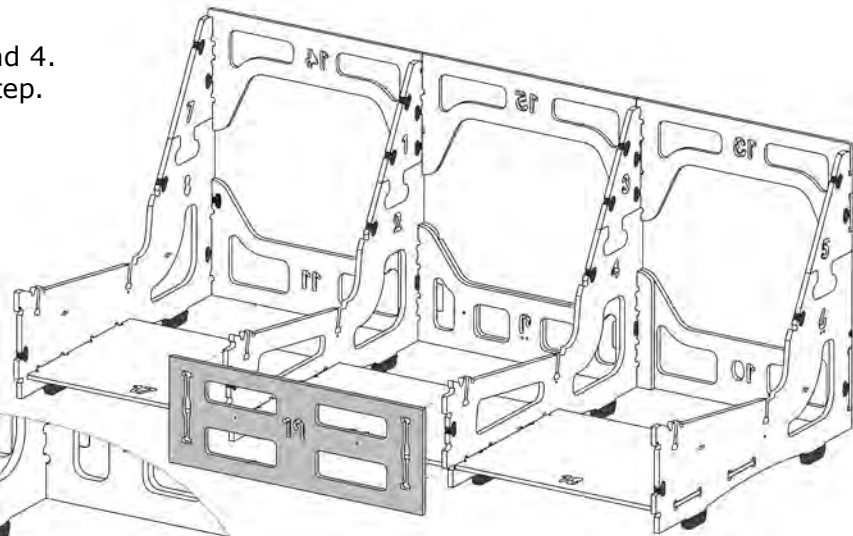

Detail Enlarged
For Clarity

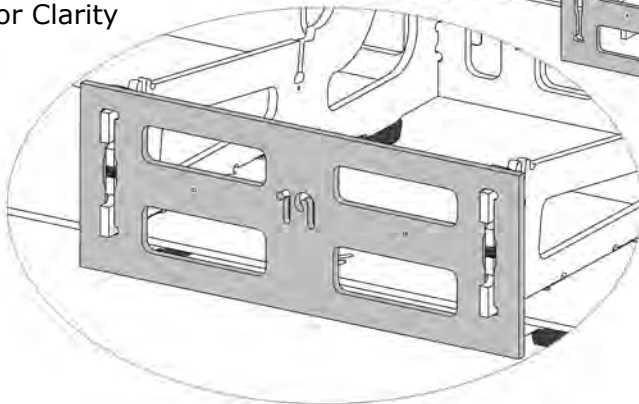

11

Move part 20 into position overlapping part 19 and connecting onto part 8, secure with three screws. Repeat process for part 21 on the other side.

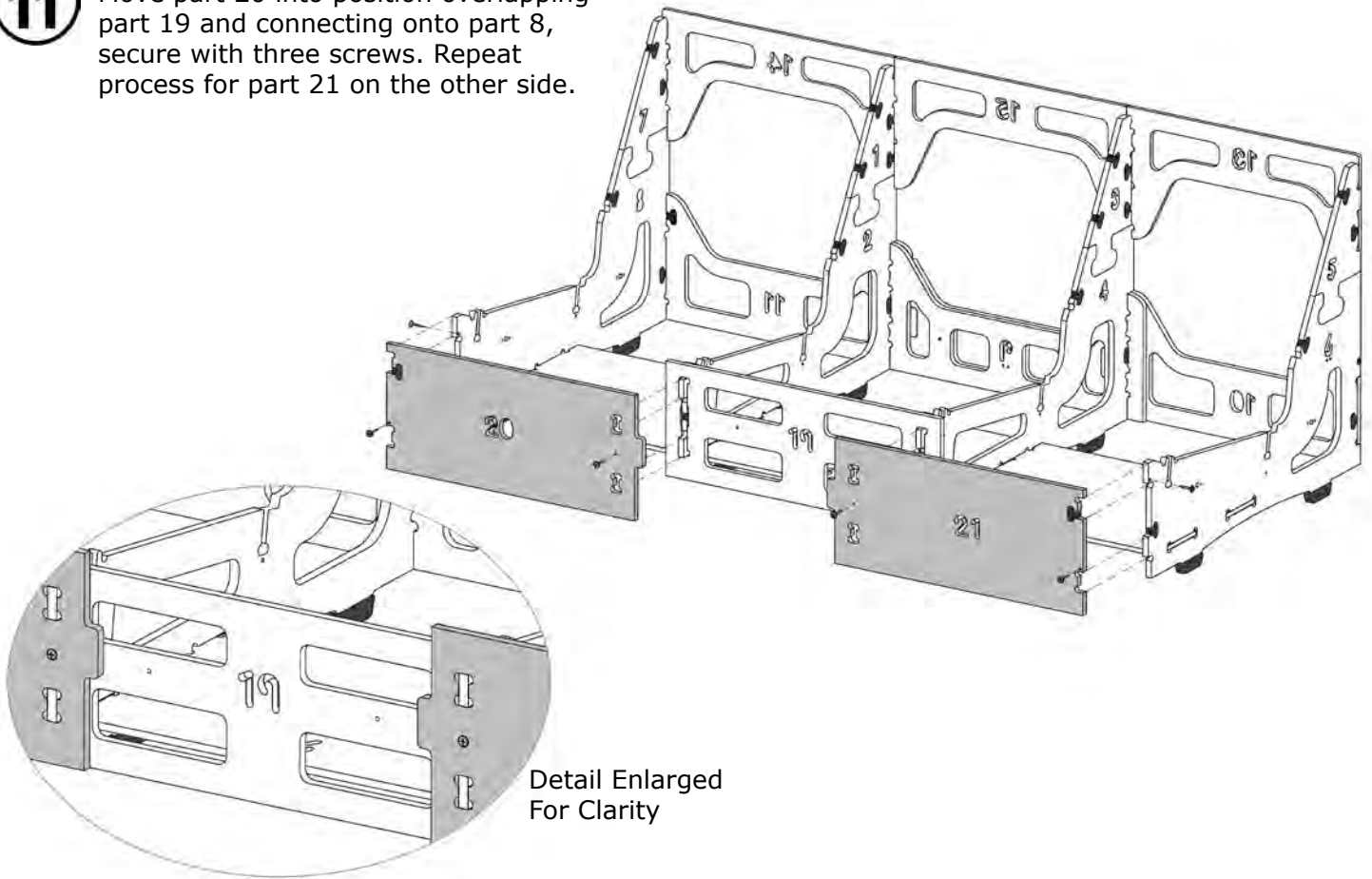

12

Align part 22 over part 19 and secure with two of the special size screws. (The special size screws for this step are in a small plastic bag labelled "For use with parts #12 and #22". These screws are slightly smaller so that they don't protrude.)

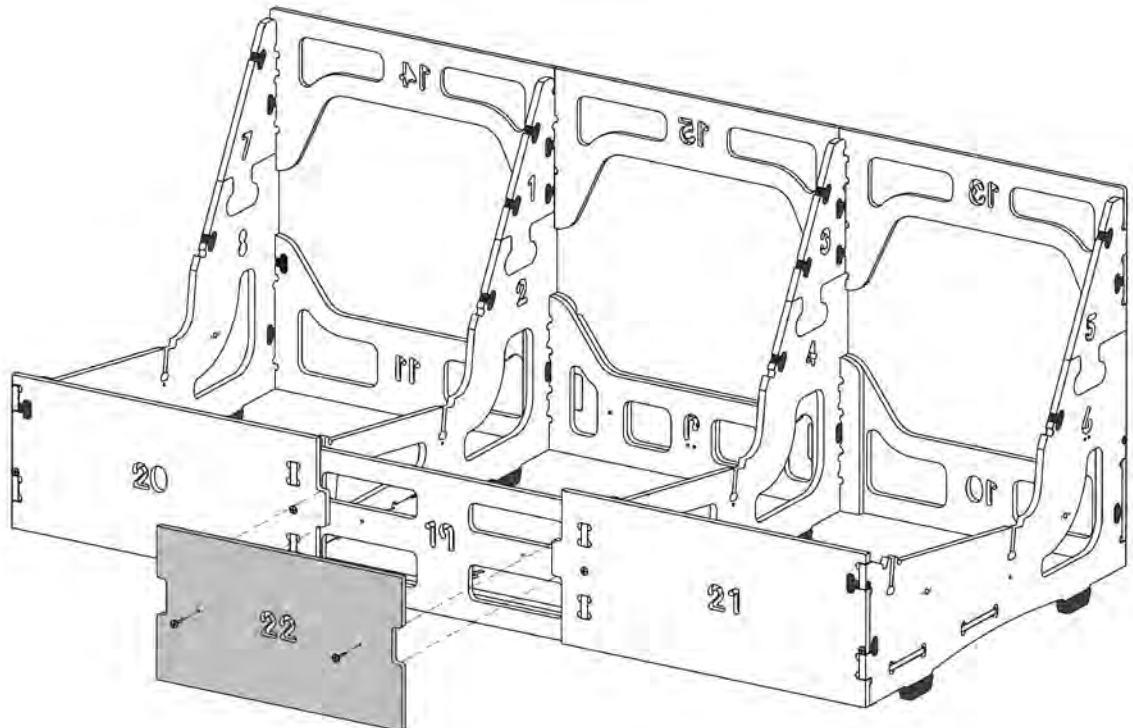

- 13** Slide part 23 into the rear slots of part 8 and 2 and secure with two screws. Slide part 24 into the rear slots of part 4 and 6 and secure with two screws. Part 25 slides down into position between 23 & 24.

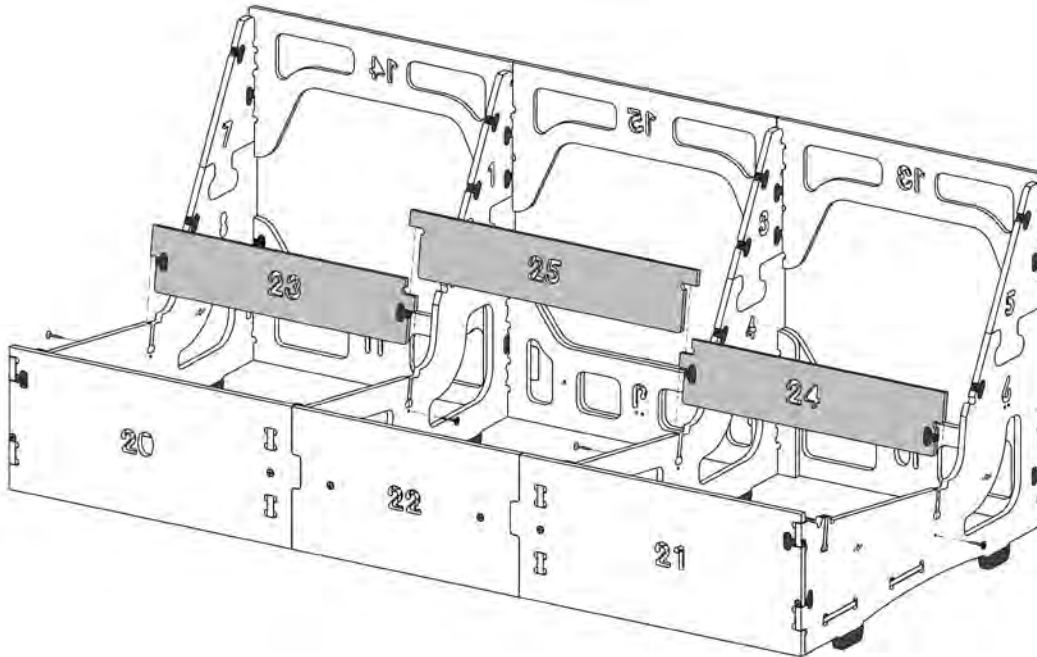

- 14** Work from left to right sliding parts 26, 27, and 28 into the slots near front of frame.

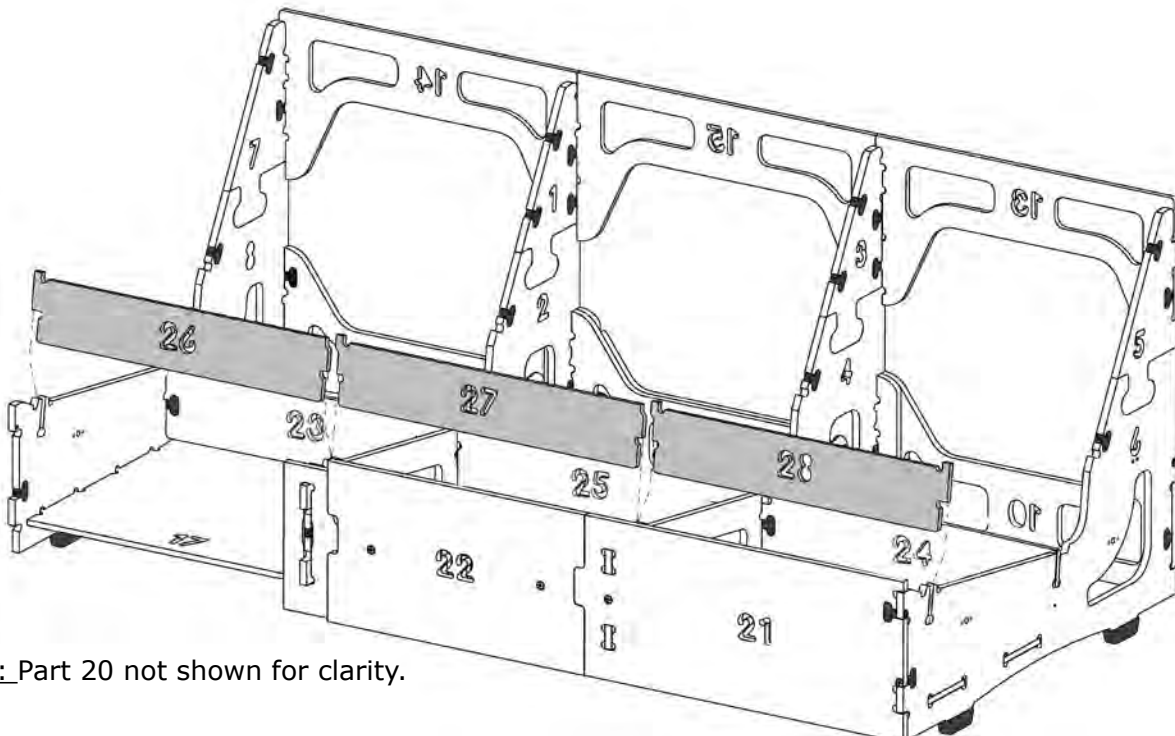

NOTE: Part 20 not shown for clarity.

15

Move part 29 into position and secure with four screws. Repeat for part 30. Move part 31 into position between 29 and 30 then secure with two screws.

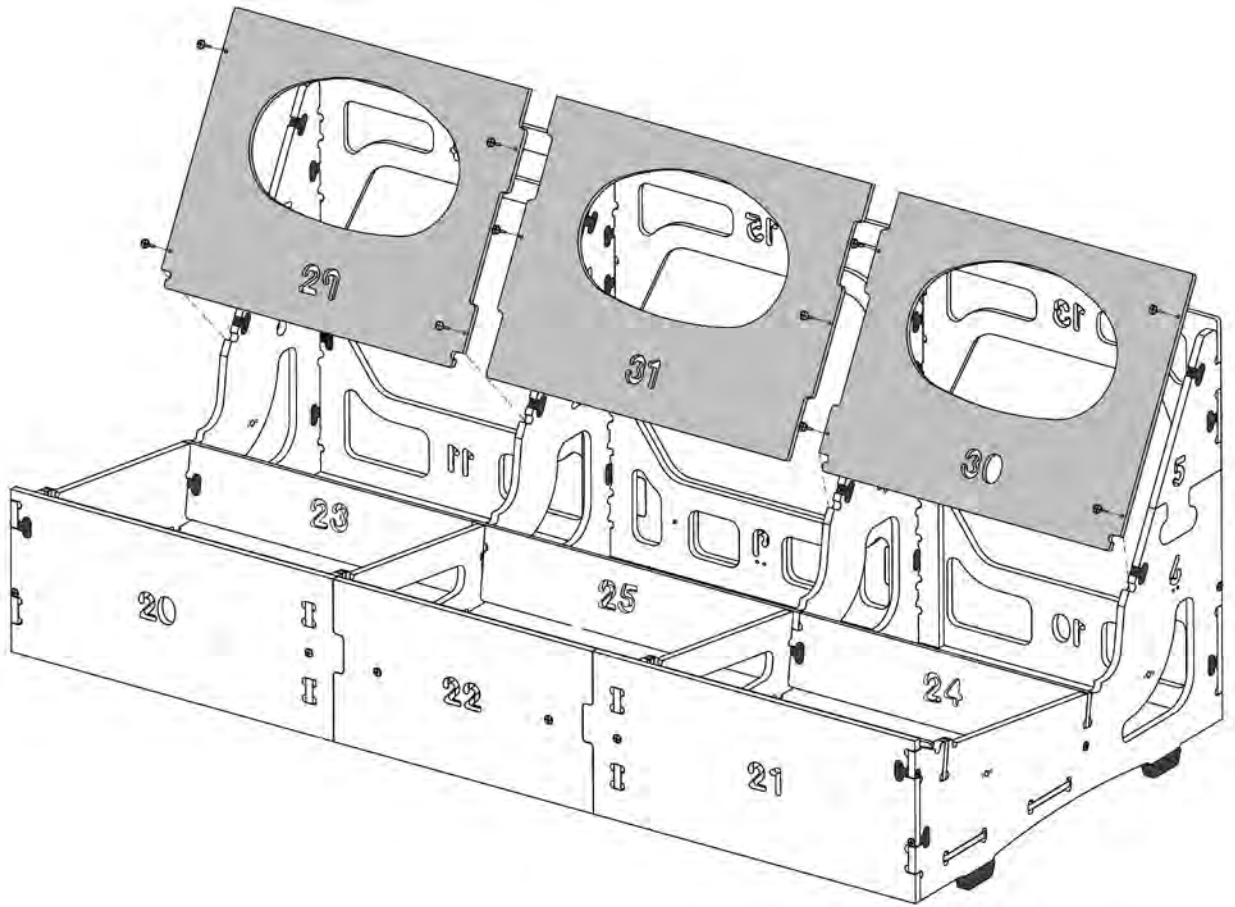

Frame assembly now complete. You will have wood pieces 32, 33, 34, 35 and 36 left over. They will all be used later on during foam and fabric assembly.

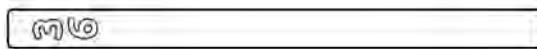
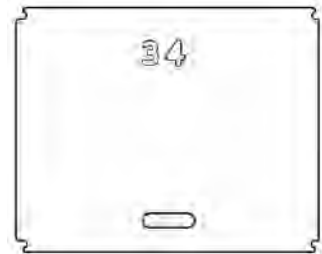
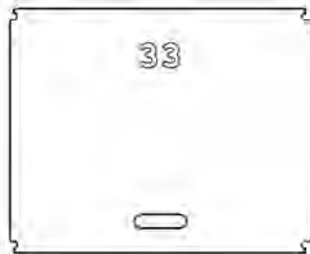

Fabric & Foam Assembly

Most of the fabric covers come inside out (It is the way they are sewn and protects the fabric surface in shipping). Unfold them all in preparation for assembly. To unfold a piece with a zipper, just pull the zipper apart as shown on the right.



You can snip off any hanging threads from the covers. They are left long during automatic trimming in the sewing process. Snipping them won't affect the strength of the seams.

Beauty tips: In addition to these printed instructions, you may want to watch our beauty tips videos on the customer service page of the website. The videos show demonstrations on how to apply the fabric covers and make them smooth and wrinkle free.

Fabrics



Frame Back Cover (1)



Seat Cushion Cover (2)



Back Cushion Cover (2)



Elite Fabric (2)

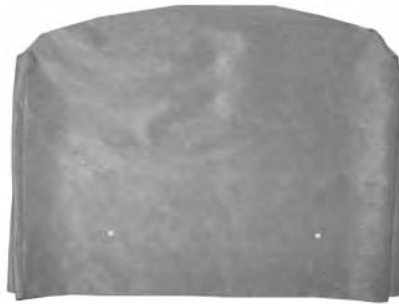

Arm Cover (2)



Frame Front Cover (1)

Foam



Seat Cushion (2)



Top Rail Piece (3)



Back Cushion (2)



Arm Foam (2)

1

Take the three Top Rail pieces and place them on the top of the frame. Push them down into position between the front and back wood pieces.



2



Take the Frame front cover as shown above.



Insert wood piece 35 all the way into the sleeve sewn into the cover.



Hold the wood firmly in place...



...and wrap the cover around the end of the wood...



...as you tuck the wood into the cover.



Repeat for the process with wood piece 36 at the other end of the cover.

3



Place the cover on the front of the frame...



...to form the front edge.



The wood piece will fit onto the frame as shown.



Put the top corners of the cover in position...



...and then pull the bottom corners of the cover around the bottom of the wood frame as shown.



Repeat the process for the other side of the frame.

4



Take the Frame Back cover (its the largest fabric piece) and place it over the back of the frame as shown.



Pull the cover down, aligning the cover seams with the edge of the frame.



Wrap the cover around and under the back corner of the frame.



Repeat the process for the other side of the frame.

5



Roll the frame onto its back.



Reach up under the cover edge, pull out the little elastic bands...



and stretch them around the black floor glides.



There will be 4 of these elastic bands. Two on the front edge cover and two on the back cover.



These keep the cover tight along the bottom of the sofa. Leave the sofa on its back and move to next steps.

6



Position the arm foam onto the arm frame.



The bottom of the foam is recessed in order to fit onto the arm frame.

7

The arm covers will fit snugly in the following sequence. The trick is to work the cover down the frame very gradually—inch by inch, as shown in the photos below—making equal progress on both sides as you go.

Be sure to visit the beauty tips video page [www.homerreserve.com/BeautyTips.cfm]. You can see a demonstration of this process, and other tricks that will keep your furniture looking beautiful.



Take the arm cover...



...and place it over the foam and frame.



Align the seams with the edges of the wood arm frame and pull the cover down an inch or two onto the frame...



Then position the cover and seams over the other end of the arm frame and work it down slightly...



Now that you have the cover positioned onto the frame at both sides, you can begin to work the cover all the way down...



...aligning the cover seams with the edge of the frame and pulling each side alternately so that neither side gets too far ahead of the other.



Once the arm cover is in place, smooth and straighten the fabric.



Flip the arm over to access the velcro attachments.



Starting with the flap in the middle, draw the sides of the arm taut by pulling up on the fabric, folding the flaps over...



...and securing the velcro together...



...follow the same procedure for the flaps at both ends of the arm...



...complete the final step on the ends by folding over the front flap and securing the velcro.



Once the arm cover is in place, smooth the fabric. Reposition the velcro flaps on the bottom of the arm, if necessary, to take out any wrinkles. Repeat these steps for the other arm cover and arm frame.

8

In these next steps we'll be joining the arms to the frame with the connector bolts from the parts bag. A cut away showing how these connector bolts will be used is shown to the right of this paragraph.

There are holes for the connector bolts at the front and back of the frames as indicated by the arrows in the diagram below.

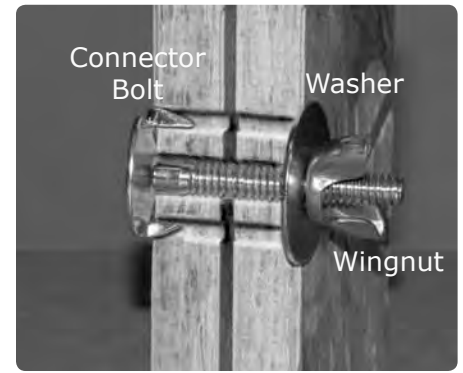

Connector Bolts

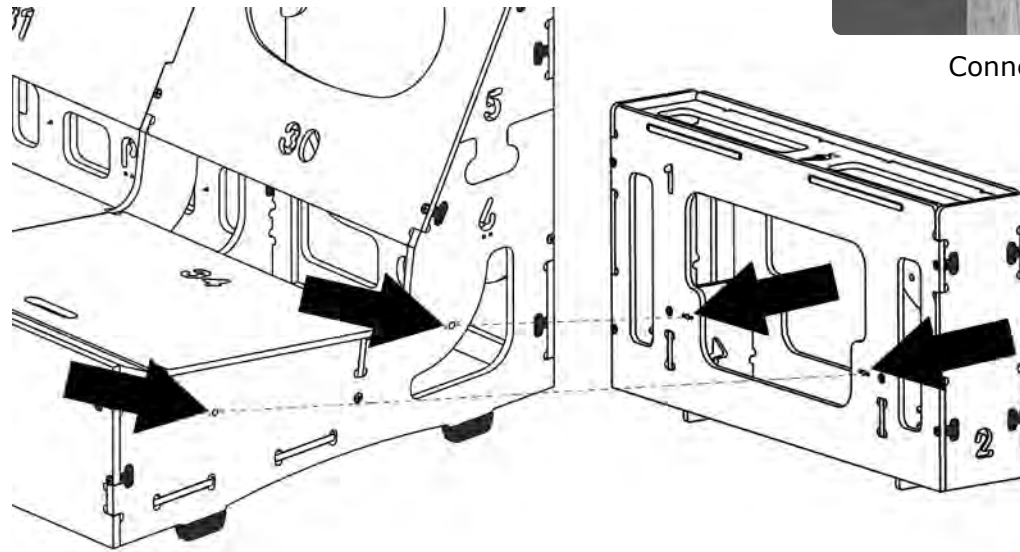

The frame is on its back from step 5, now turn the arms over as well. Notice the holes in the arm fabric...



...they go up against the frame.



Follow the next steps to attach the connector bolt at the back of the frame (The hole closest to the floor with the frame on its back).



Reach inside the arm and insert the connector bolt into the hole.



The two prongs on the connector bolt go into the two small holes. This keeps the bolt from turning.



The arm is moved away from the frame in this photo so that you can see how the connector bolt protrudes through the circular hole cut in the fabric.



With the arm pushed against the frame, continue to insert the connector bolt through the frame as shown.



Take the washer and wingnut and get them started onto the bolt. Don't tighten completely.



Now put the connector bolt that goes up at the front of the frame into place.



You may need to stand up and reach over the front rail in order to improve visibility and complete installation of the washer and wingnut.



Once the connector bolts are in position at both front and back, tighten the wingnuts to draw the frames together.

9



10

Find the Seat Cushion Covers and Seat Cushion Foams and follow the sequence below.



Match the rounded front edge of the seat cushion foam with the rounded edge of the seat cushion cover.



Position the cover over the foam and align the corners of the foam cushion with the corner seams of the cushion cover.



You can stick your hand right up in there to get everything smooth.



Working your way around the sides of the cushion pull the corners of the cover onto the foam...



...and zip up the cover.



Place the seat cushions on the frame. The rounded edge of the cushions goes toward the front.

11

Cover the back cushion with the elite fabric. The elite is a white silky material that will help you slide the cover over the foam in step 11. Without the elite the cover sticks to the foam and is hard to get into position.



Start by laying the elite over the wedge shaped area of the back cushion.



Leave enough overlap so that you can...



...wrap it up under the wedge.



Now bring it over the top of the foam...



...stretch it out wide...



...and lay it down the front of the foam.



Position the elite across the bottom ...



...and then bring it back up the foam so that you finish under the wedge shaped area.



Smooth the sides and make sure all the foam is covered.

12



Take the back cushion cover and place it over the side of the elite covered back cushion foam. Start at the top corner.



Fill in the wedge shaped area and the top of the cover. You can work the materials with your hands and also reach up under the cover to smooth and straighten.



Turn the cushion over, smash down the foam and as you release it, guide the foam...



...so that it pops back up into the wedge shaped area and the top of the cover. Straighten as



Work the cover down along the sides...



...wrap the cover around the corners of the foam...



...and start zipping the cushion closed.



Zip the bottom...



...and up the other side.



Once the zipper is closed, you can work the cover with your hands to make it all fit evenly. Wide sweeping motions work better than small movements.



Make sure the cover is pressed all the way up into the wedge area.



The back cushion is now ready to be placed on the frame. Repeat these steps for the other back cushion.



Place the back cushions on the frame.



Congratulations, assembly is now complete.



SEAT DEPTH ADJUSTMENT

The furniture is designed to allow for seat depth adjustments. The normal setting for the cushions to protrude is 1½" out in front of the frame. Slide the seat cushion in or out to adjust to your own seat depth preference.



REMEMBER

You can snip off any hanging threads from the covers. They are left long during automatic trimming in the sewing process. Snipping them won't affect the strength of the seams.

Blank

HOME | RESERVE

Home Reserve products are
made in the USA under patents:

#6,267,446

#6,568,058

#6,981,747

#7,044,557

