



Corner ottoman

assembly instructions





Smooth & Wrinkle-Free Fabric Covers:

In addition to these printed instructions, you may want to watch our beauty tips videos on the customer service page of our website. The videos show demonstrations on how to apply the fabric covers and make them smooth and wrinkle free.



Renewability: Individual foam and fabric parts are available. You no longer have to worry that something will happen and you'll just have to live with it. From pet attacks to paint spills, it's easy to recover from a furniture accident.

CUSHIONS

Foam: The seat cushions will feel firm at first. That's intentional, since firmer foam lasts longer. You can shorten the break-in period by putting the cushions on the floor and walking on them for a few minutes.



Fabric Exchange: To use our 30-day fabric cover exchange program, contact us and we'll lead you through the process. Keep the covers out of actual use to preserve them in new, unused, and clean condition. Fold them neatly when repackaging to avoid wrinkles.

FRAME ASSEMBLY

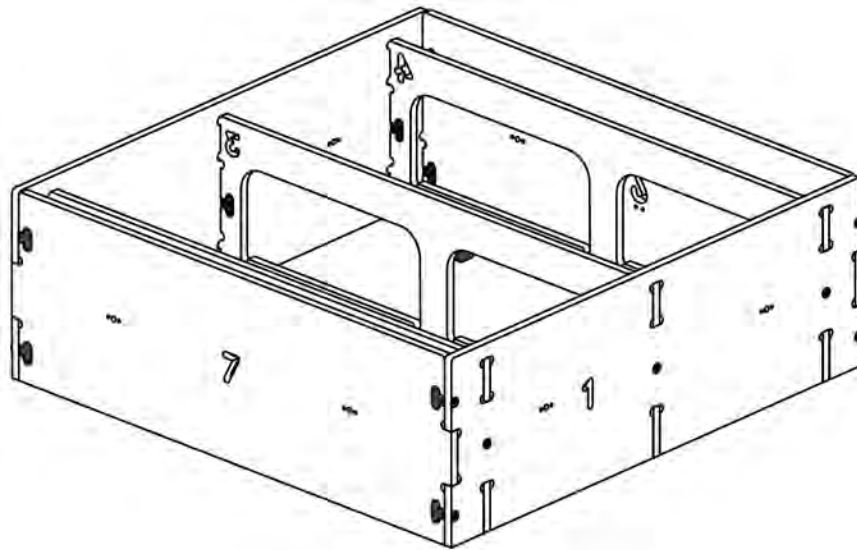

Tools needed: Phillips Screwdriver or powered drill with a Phillips screwdriver bit.

A sanding pad is included in case you wish to smooth over any of the surfaces or edges after the frame is assembled. It is not necessary to sand any of the frame parts during assembly. No glue will be used during assembly. Item will be ready for use immediately.

1

Insert the black plastic T-connectors into the parts shown here. (Throughout the instructions it's OK to use a hammer to tap the T-connectors and wood parts into position.)

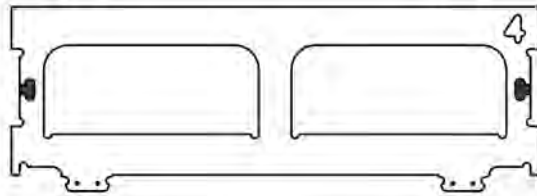
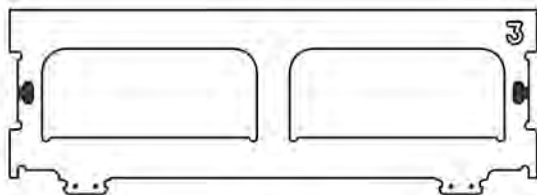
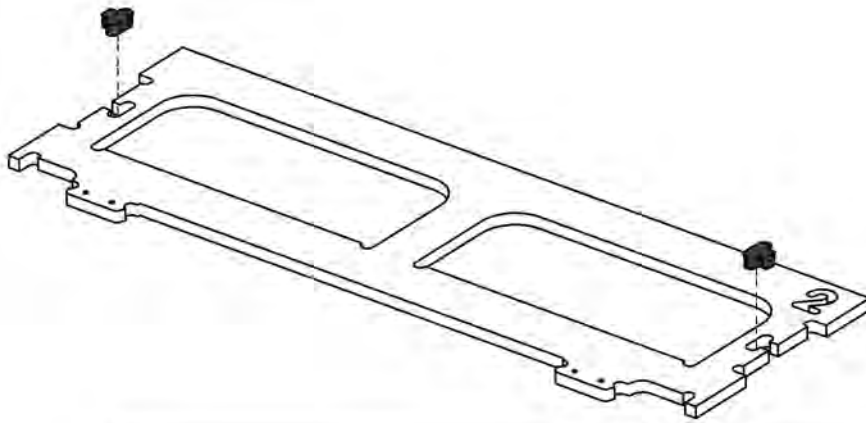

2

Attach black floor glides to the parts shown.

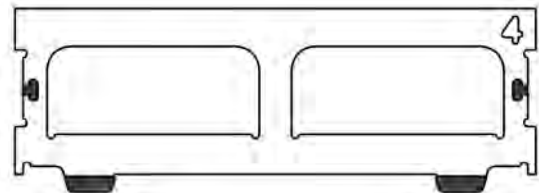
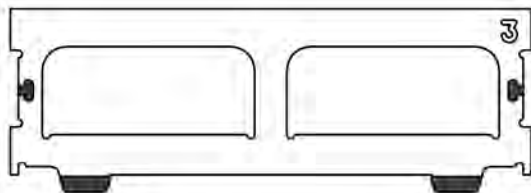
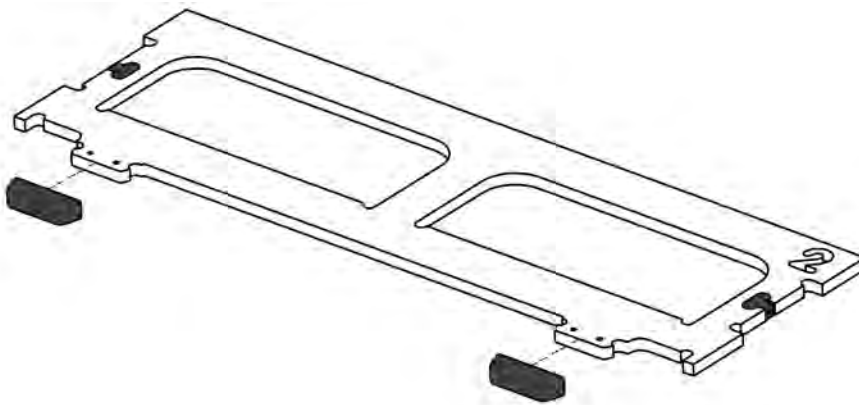

- 3** Slide part 2 into the slots on part 1 and secure with a screw.

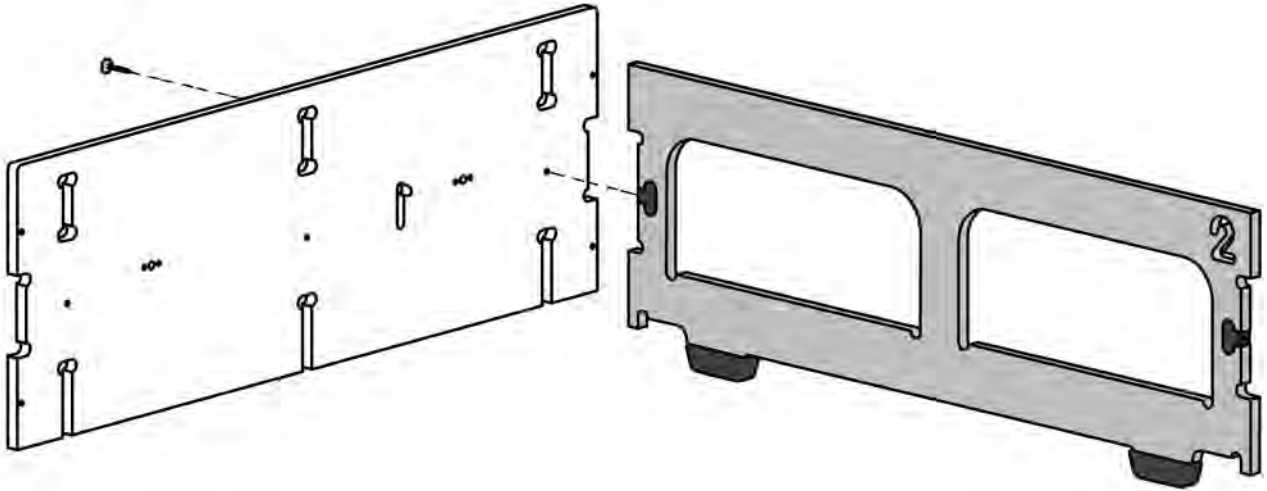

- 4** Slide part 3 into the slots on part 1 and secure with a screw.

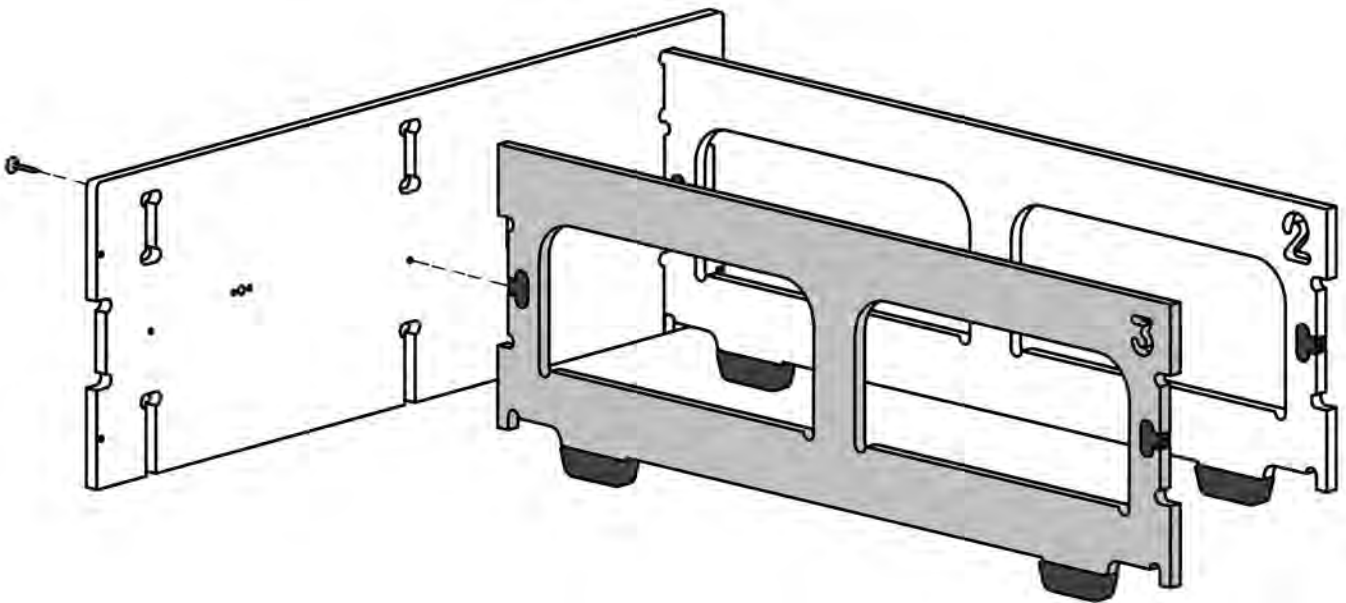

5 Slide part 4 onto part 1 and secure with a screw.

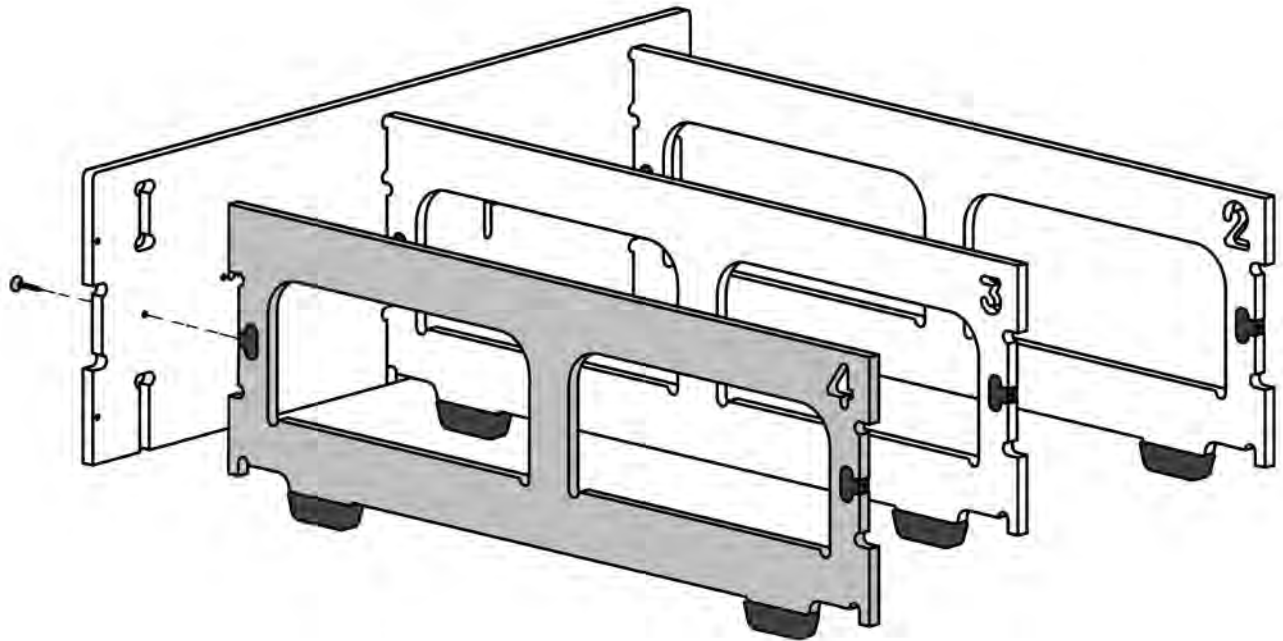

6 Slide part 5 onto part 2, 3 and 4 then secure with three screws.

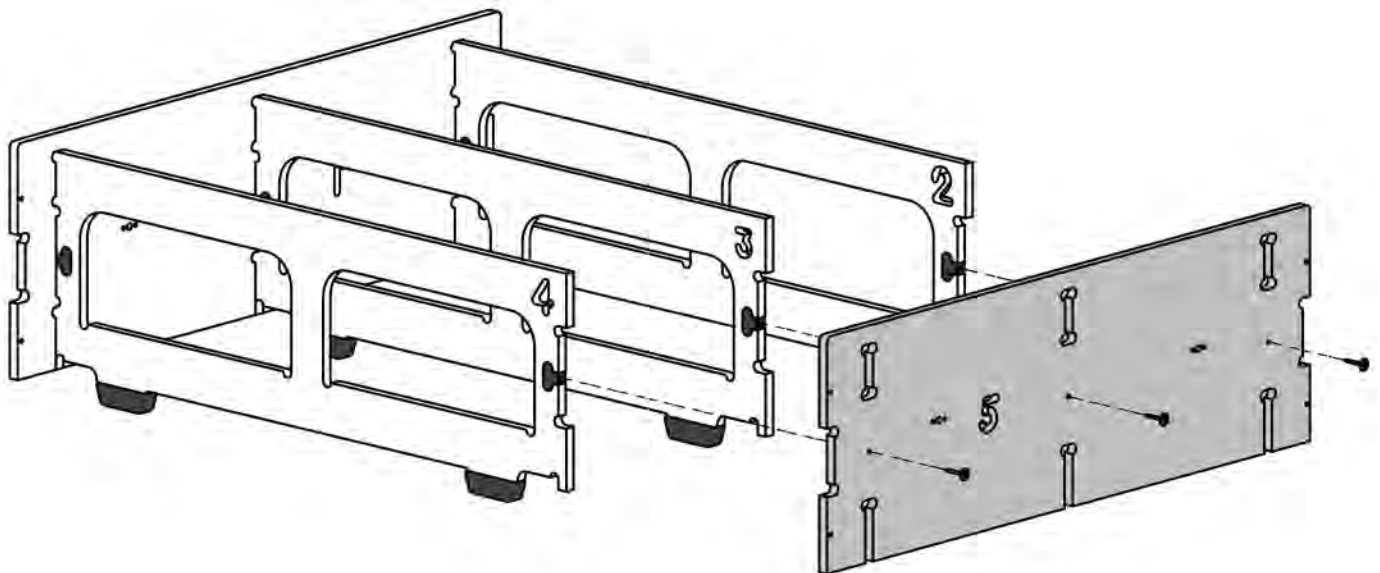

7 Slide part 6 onto part 1 and 5 then secure with four screws.

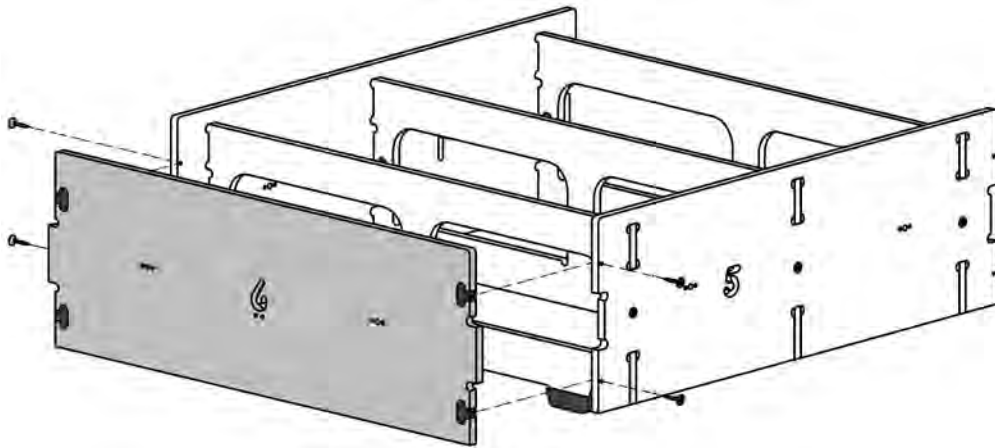

8 Slide part 7 onto part 1 and 5 then secure with four screws.

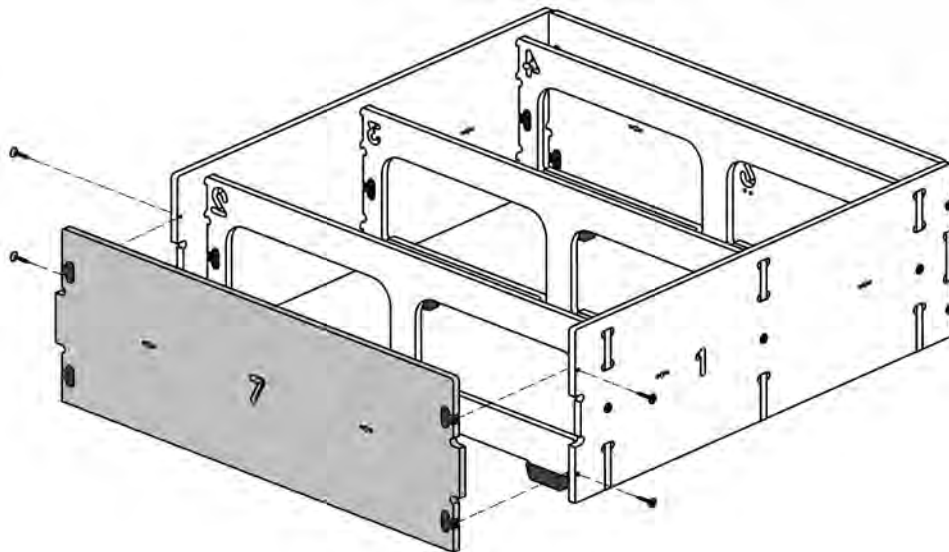

This completes the frame assembly.
Parts 8, 9, 10 & 11 will be used later during fabric & foam assembly.

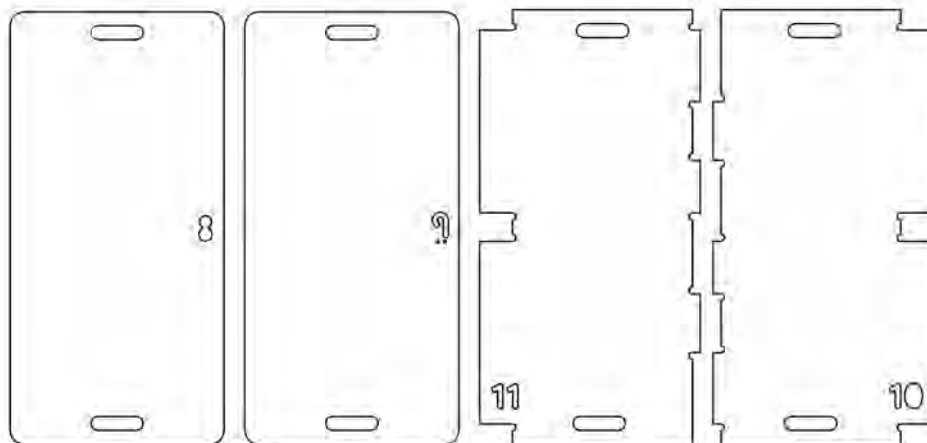

Fabric & Foam Assembly

1

The cushion cover comes inside out. (It is the way it is sewn and protects the cover surface in shipping.) Unfold it in the manner shown below. You can trim off any of the loose hanging threads, it won't affect the strength of the seams. They are left long during automatic trimming in the sewing process.

WATCH A VIDEO

You will find it helpful to watch a short video on how to apply the fabrics. Go to our web site, click on Customer Service, and then select "Beauty Tips Videos."



Start by pulling the cover apart at the zipper knob and then open the zipper.



With the zipper open you will see two flaps.



Reach into the bottom area (under the 2 flaps) to unfold the cover.



When you have it all unfolded, set the cover aside.

2



Lay the white silky material on the ground. Place the foam on top of it.



Fold the silky material all the way up and around the foam until the foam is completely covered. The silky material will help the foam slide into the cover.



Get the cushion cover, fold the foam over in half and slide it all the way into the cover.



Then reach a hand way up inside the cover to work the foam into position on the corners and get the fabric all straightened out.



Zip up the cover.

3

Slide wood part 8 and wood part 9 into the pockets in the cushion cover, and set it aside.



4

The following sequence will show you how to cover the frame with the remaining cover piece.



Identify the bottom edge of the cover. The tan flaps are attached to the top.



Now find one of the seams.



Align this seam with the corner made by wood parts 1 & 7. Slide it down about one inch over the frame.



Go around the frame and slide the cover about one inch over the other three corners.



Now that you have the cover started onto all four corners of the frame, you can begin to work it down into position by...

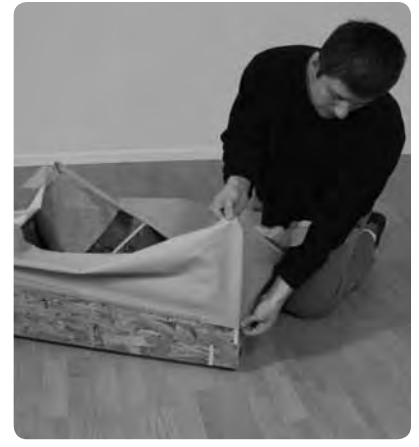

...holding the top of the cover high and pulling the cover down. Work each corner alternately so that no one corner gets too far ahead of the other.



Continue until the cover overhangs the frame equally on both top and bottom.



Position the tan flaps inside the frame and flip the frame over.



Now that the ottoman is upside down, work your way around the frame pulling up the tan flaps, smoothing out the cover..



...and aligning and securing the Velcro.



Push the cover at the four corners down into the frame.



Once the Velcro is secured, you can flip the frame back onto its feet.

5



Take wood pieces 10 and 11 and place them down inside the ottoman. These pieces are the bottom of the storage compartment.



Pick up the cushion assembly and position wood part 8 and 9 which are inside the pocket...



...into the frame along the back edge of the ottoman and lower the lid onto the ottoman.



Congratulations, assembly is complete.

Attaching a Corner Ottoman to a Sectional Unit

There will be two connector bolts included in the parts bag. These will be used only if you are connecting the modular ottoman to a sectional unit or another ottoman.

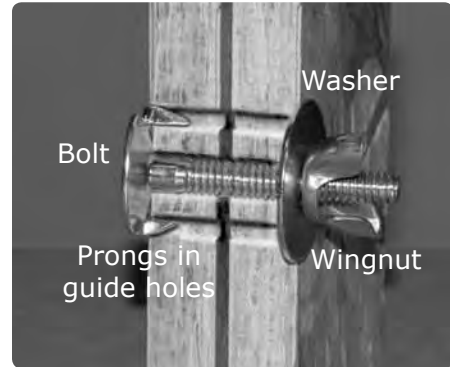

Connector Bolt

There are holes for the connector bolts on the sides of the ottoman and sectional unit as indicated by the arrows in the diagram below.

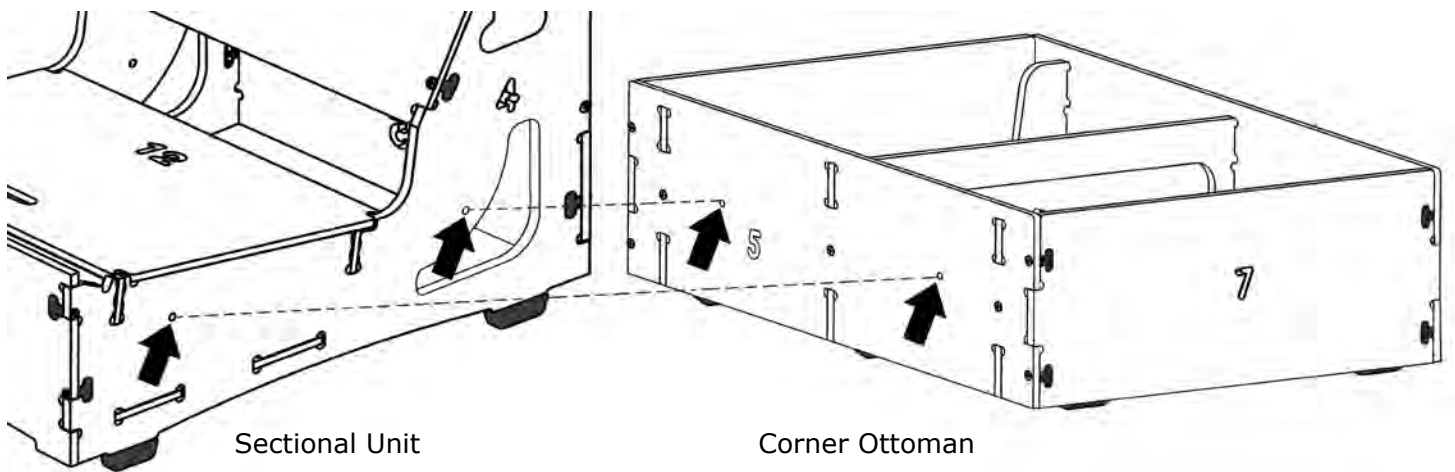

Sectional Unit

Corner Ottoman



In order to get a connector bolt through the fabric wrapping...



...place a small slit in the fabric where the bolt will protrude through the wood.



Repeat for the inside flap.



Then align the frames as shown...



...and slide the connectors into the holes.



Tighten the bolts to draw the frames together.



REMEMBER

You can snip off any hanging threads from the covers. They are left long during automatic trimming in the sewing process. Snipping them won't affect the strength of the seams.

Blank

Blank

