



Armless

tightback loveseat

assembly instructions





Smooth & Wrinkle-Free Fabric Covers:

In addition to these printed instructions, you may want to watch our beauty tips videos on the customer service page of our website. The videos show demonstrations on how to apply the fabric covers and make them smooth and wrinkle free.



Renewability: Individual foam and fabric parts are available. You no longer have to worry that something will happen and you'll just have to live with it. From pet attacks to paint spills, it's easy to recover from a furniture accident.

CUSHIONS

Foam: The seat cushions will feel firm at first. That's intentional, since firmer foam lasts longer. You can shorten the break-in period by putting the cushions on the floor and walking on them for a few minutes.



Fabric Exchange: To use our 30-day fabric cover exchange program, contact us and we'll lead you through the process. Keep the covers out of actual use to preserve them in new, unused, and clean condition. Fold them neatly when repackaging to avoid wrinkles.



Box 1 makes the left side of the frame.

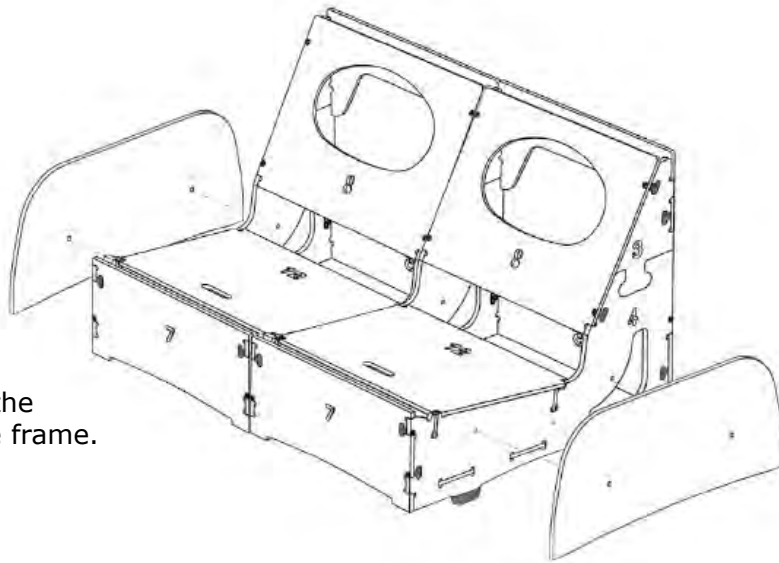

Box 2 makes the right side of the frame.

Tools needed: Phillips Screwdriver or powered drill with a Phillips screwdriver bit.

A sanding pad is included in case you wish to smooth over any of the surfaces or edges after the frame is assembled. It is not necessary to sand any of the frame parts during assembly. No glue will be used during assembly. Item will be ready for use immediately.

Box #1 Frame Assembly

Now you can take all the remaining wood parts out of box #1. These parts are not packed in order of assembly so don't worry about getting them mixed up. They are all numbered for easy reference.

- 1** Insert the black plastic T-connectors into the parts shown here. Throughout these instructions it's okay to use a hammer to tap the T-connectors and wood parts into position.

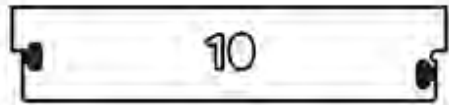
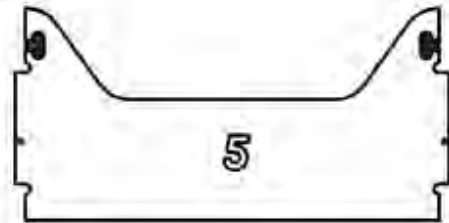
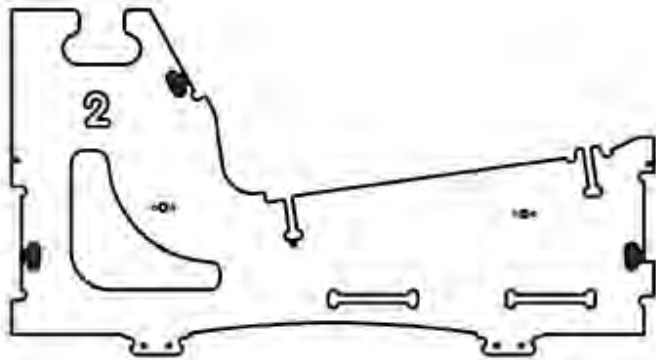
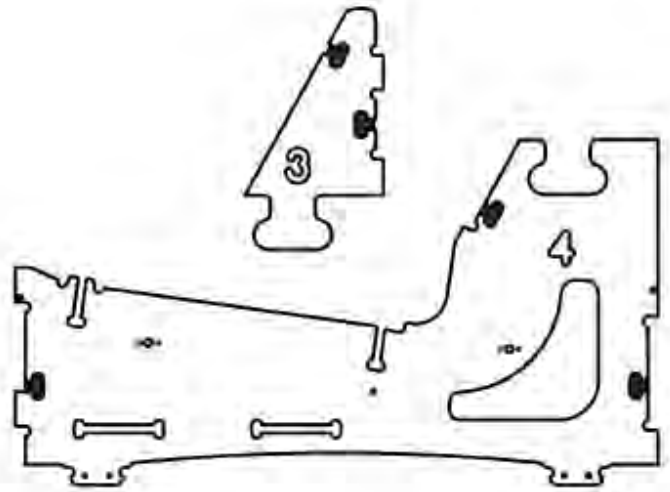
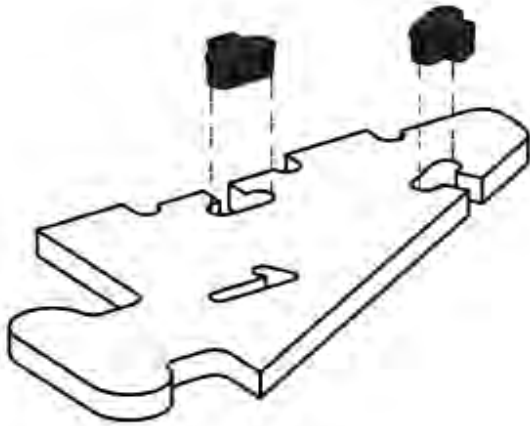

2 Attach black floor glides to the parts shown.

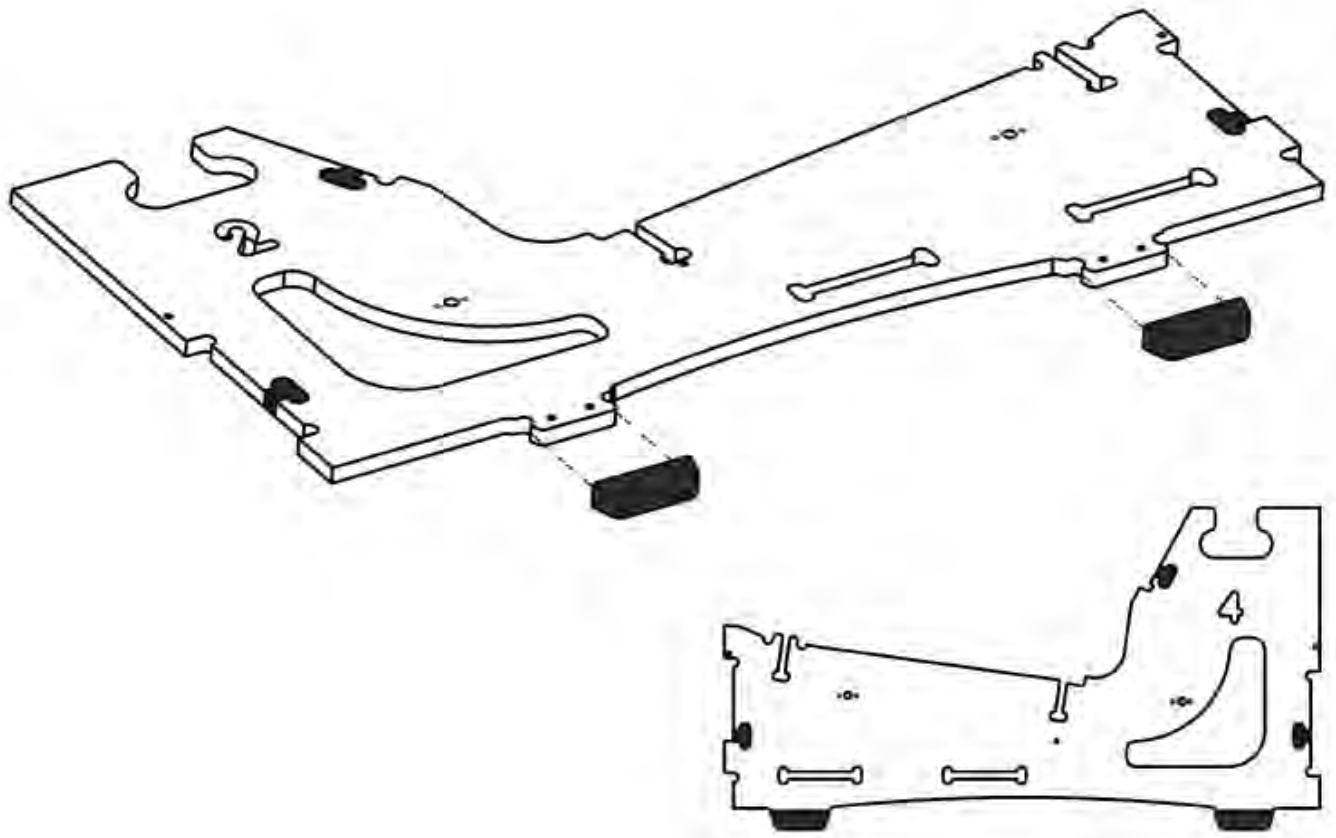

3 Connect parts 1 and 2 together. Repeat for parts 3 and 4.

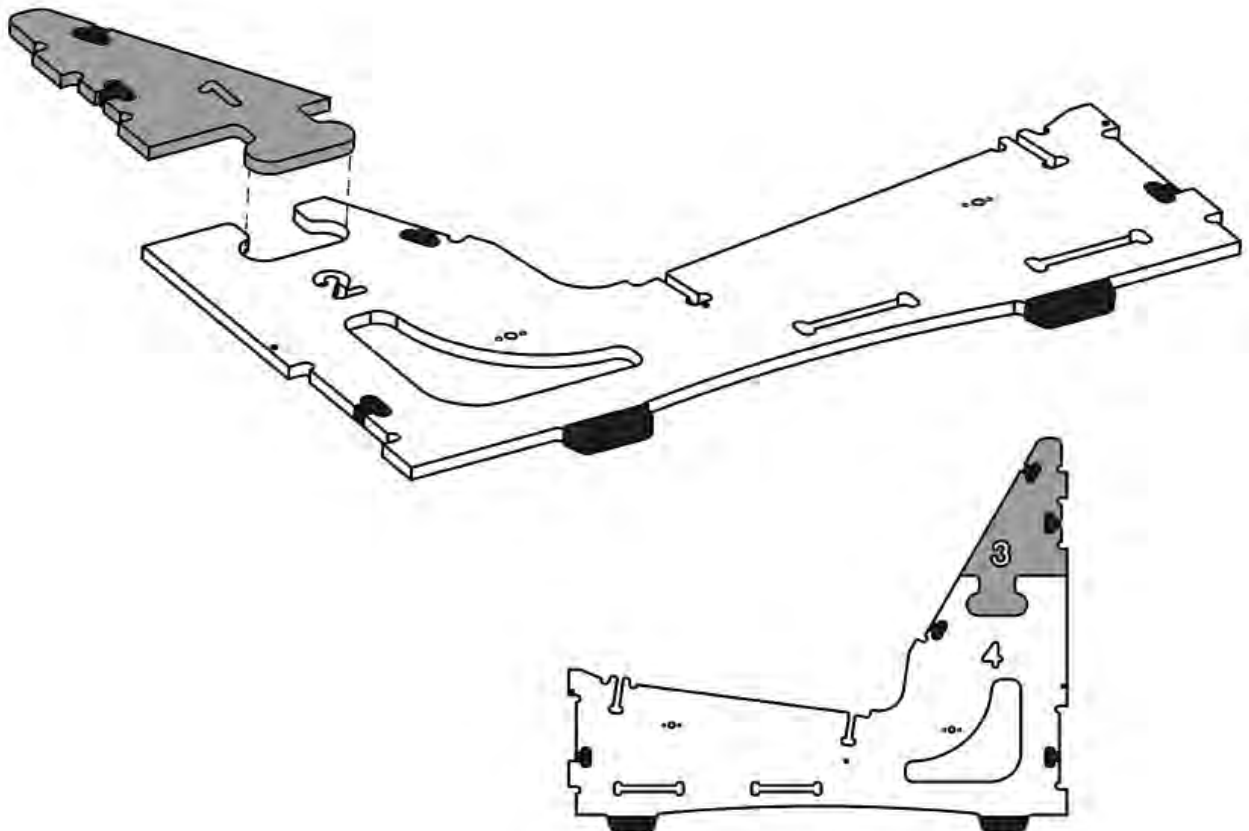

4 Slide part 5 onto part 2 and secure with two screws.

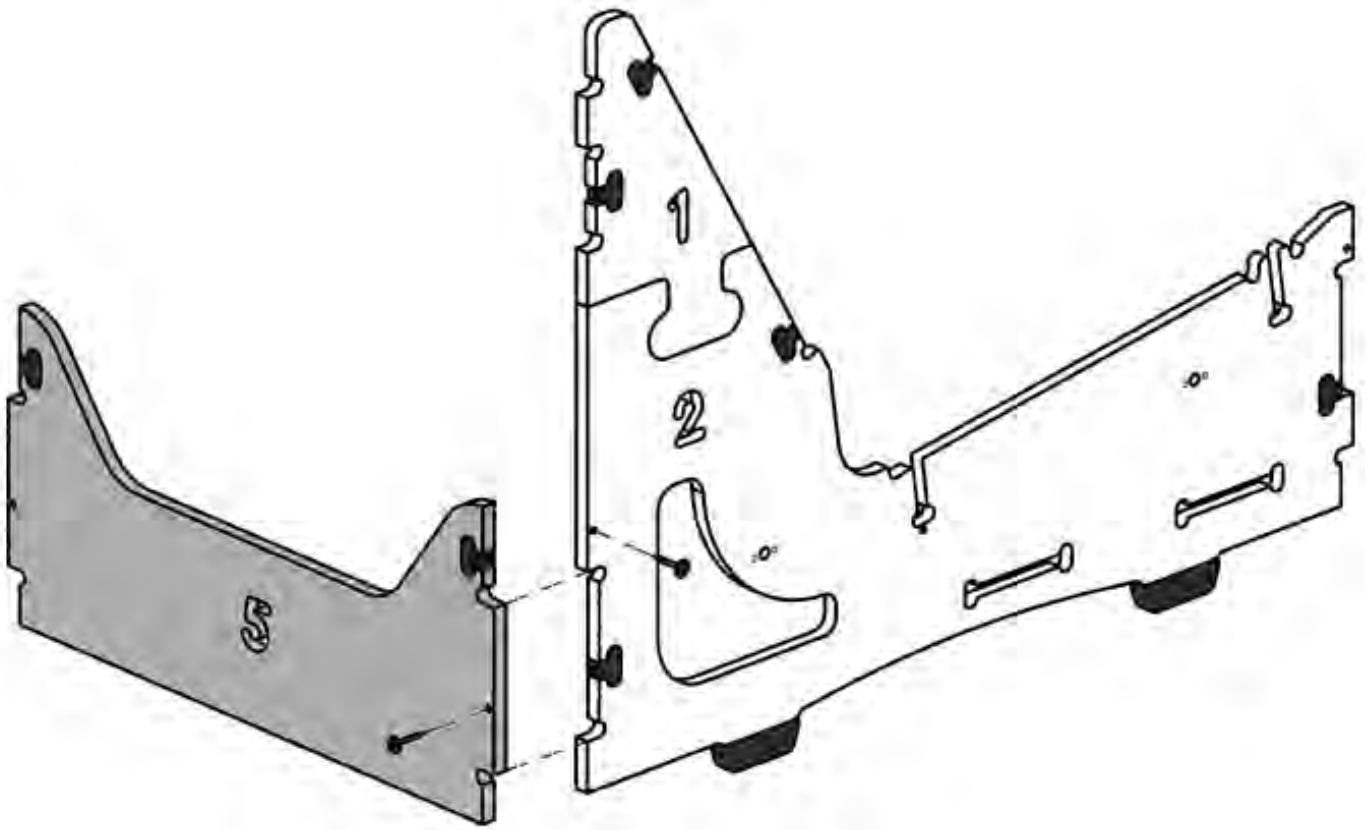

5 Slide part 4 onto part 5 and secure with two screws.

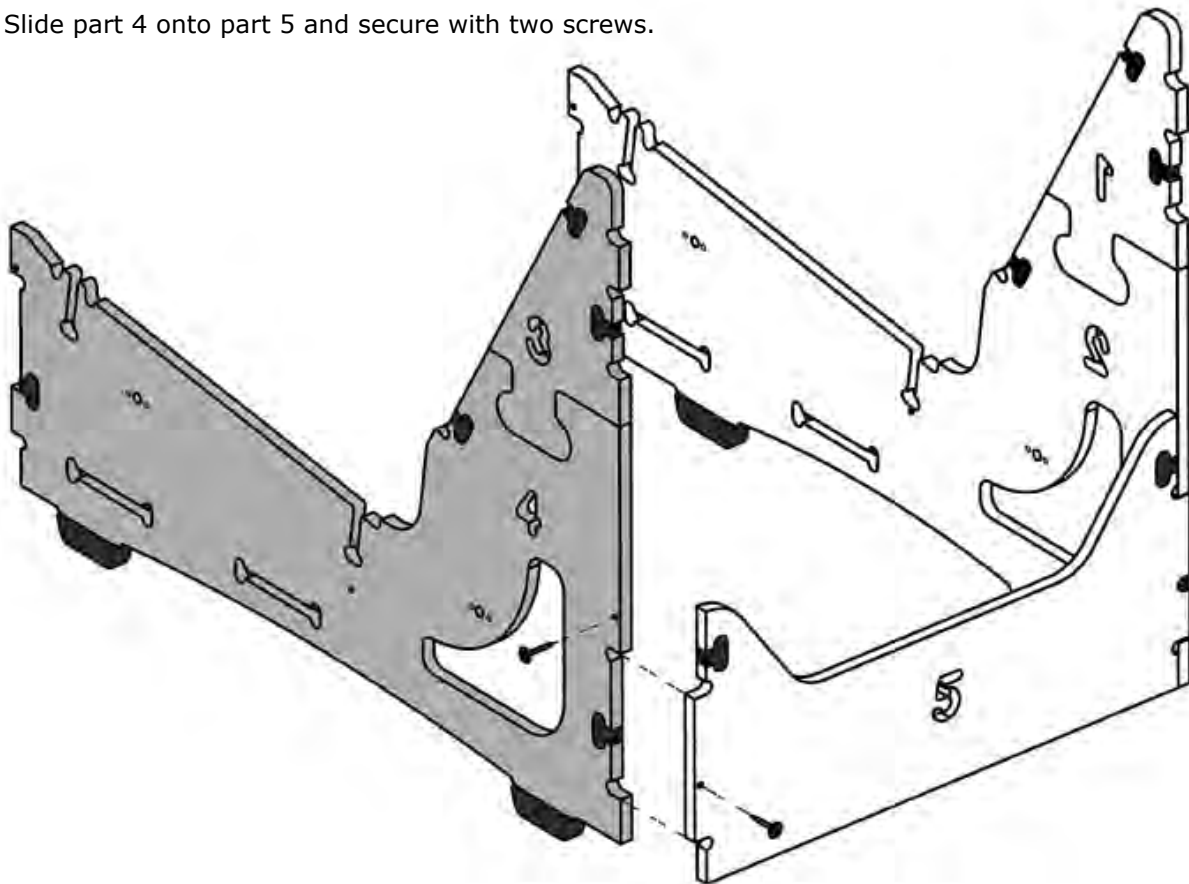

6

Spread parts 2 and 4 apart far enough to slide part 6 into the slots on 2 and 4.

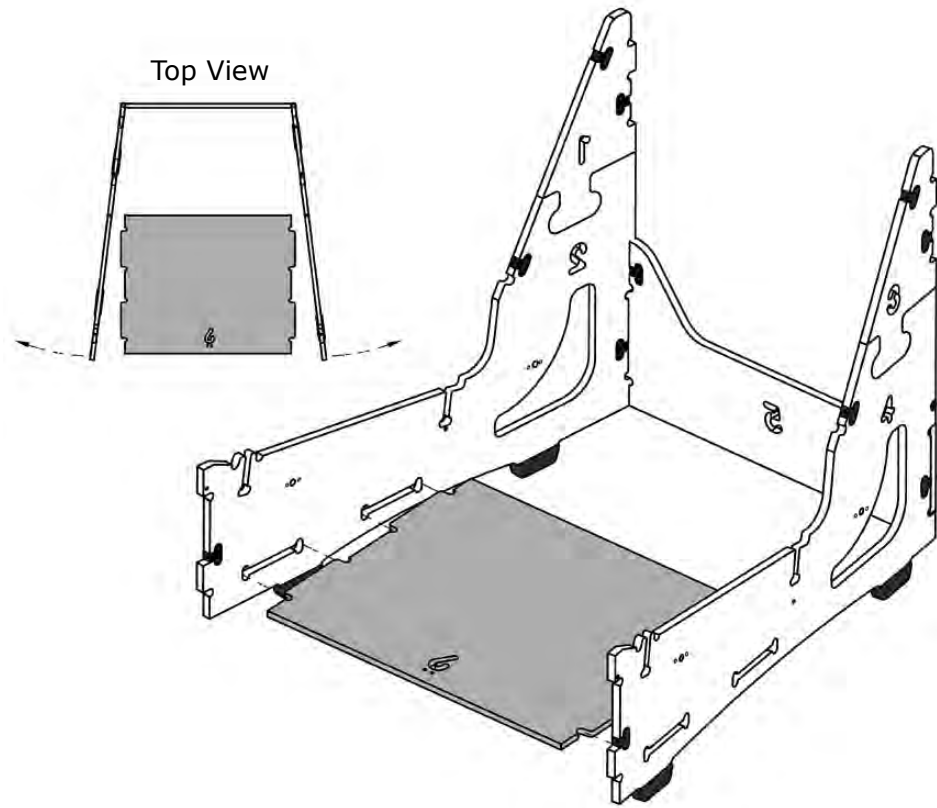

7

Slide part 7 onto parts 2 and 4. Secure with four screws.

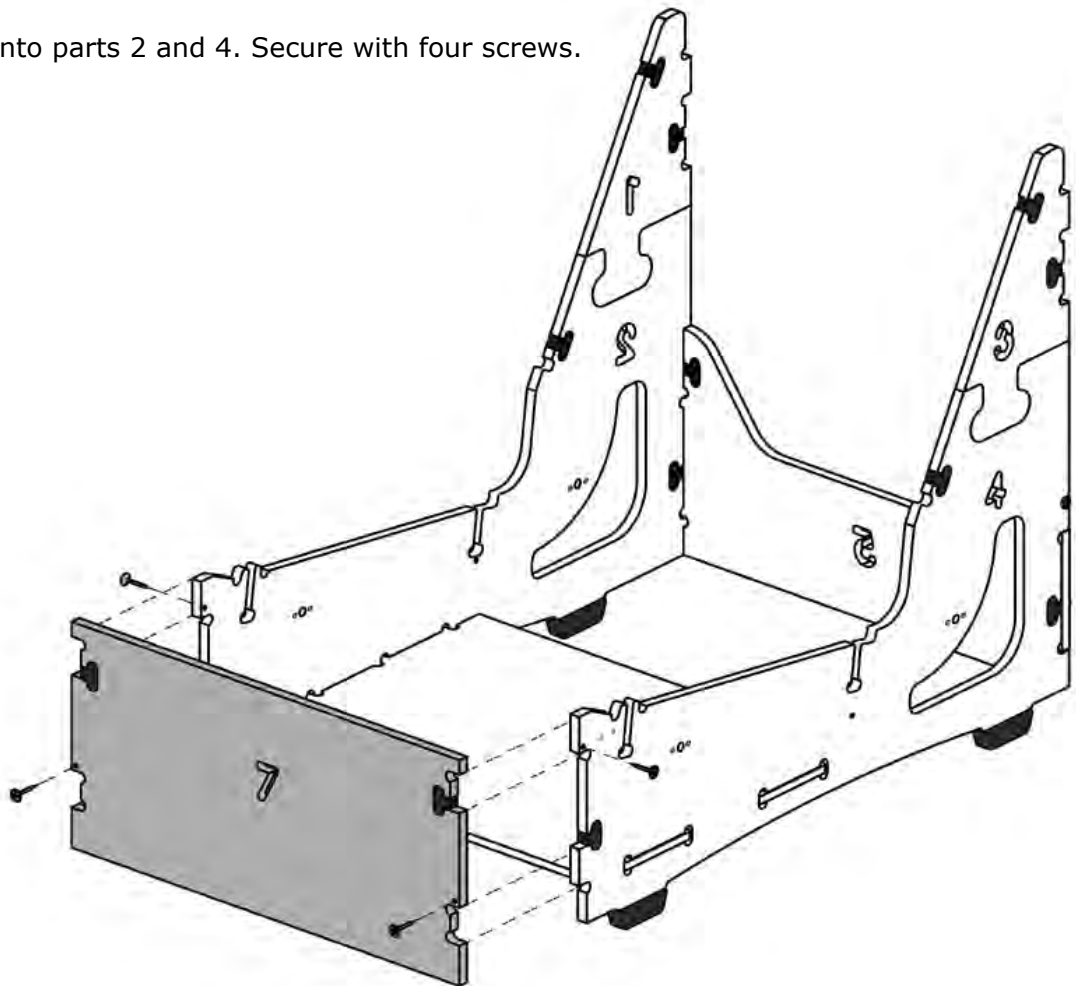

8

Place part 8 onto parts 1 and 2 and parts 3 and 4 and secure with four screws.

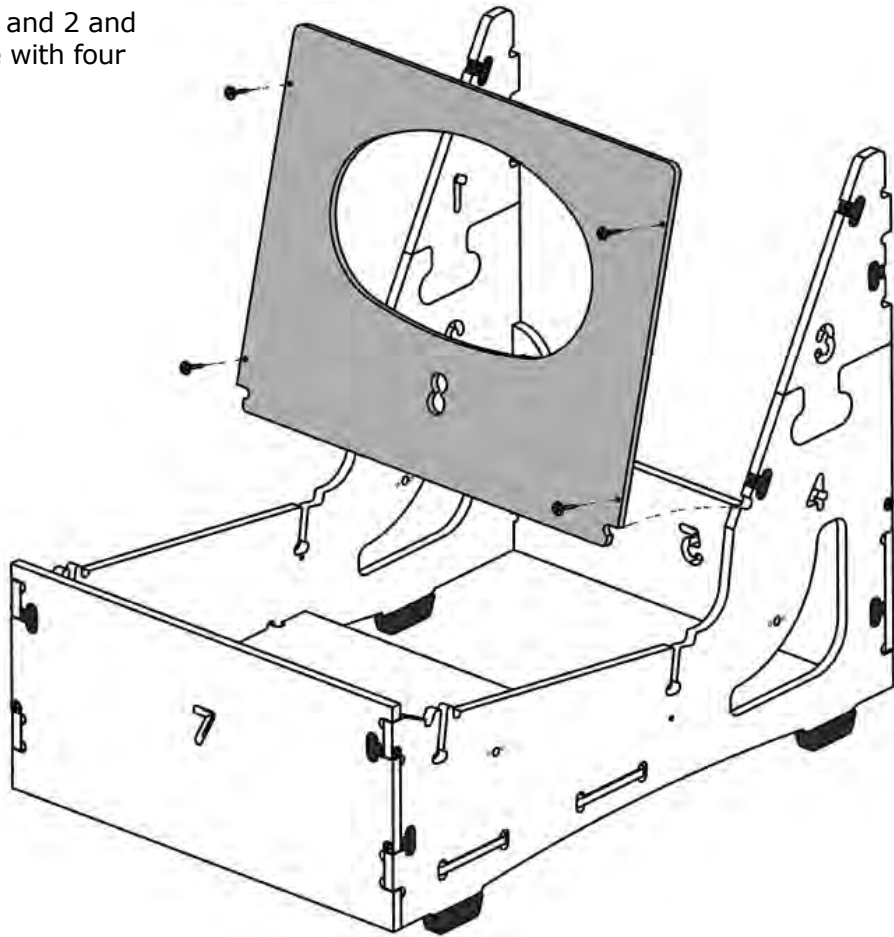

9

Place part 9 onto parts 1 and 3 and secure with two screws.

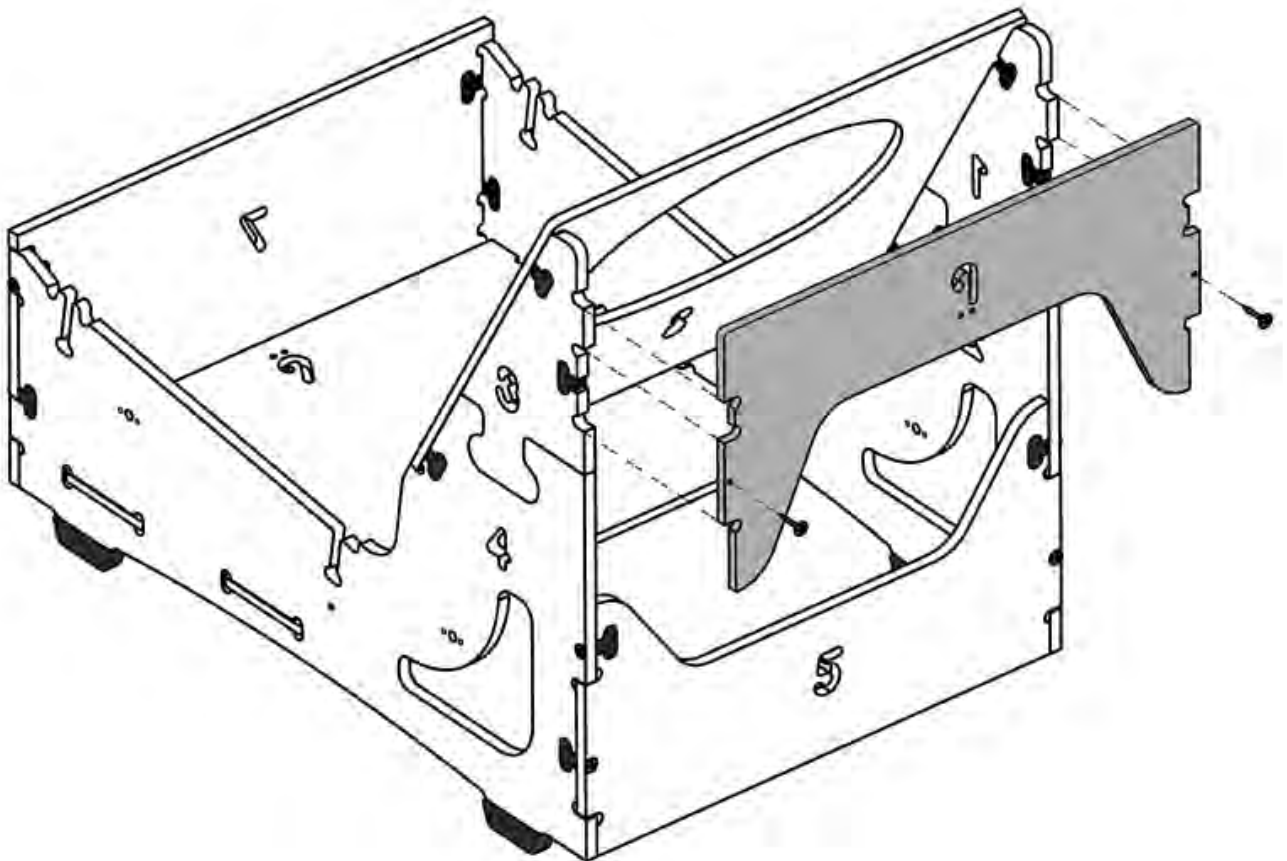

- 10** Place part 10 into rear slots located on parts 2 and 4 and secure with two screws.

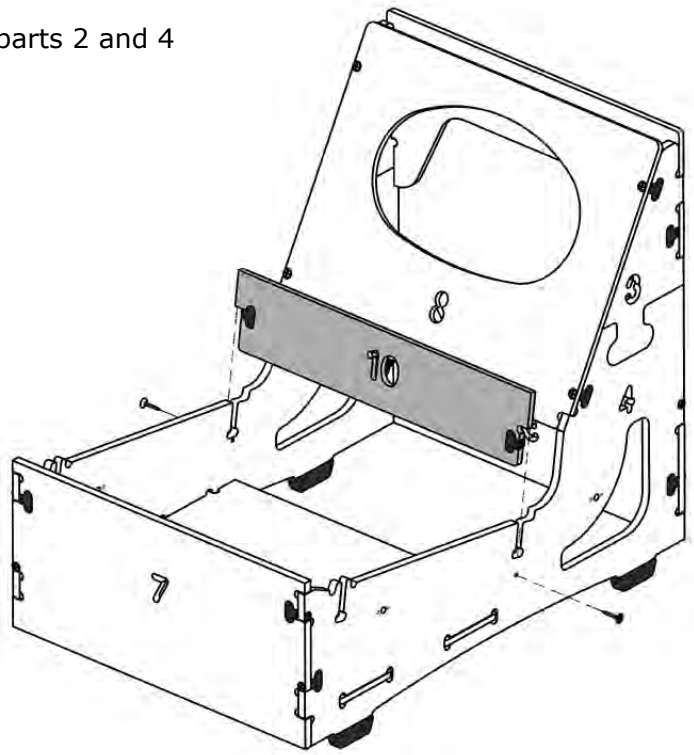

- 1** Slide part 11 into the front slots located on parts 2 and 4. Box #1 Frame Assembly now complete.

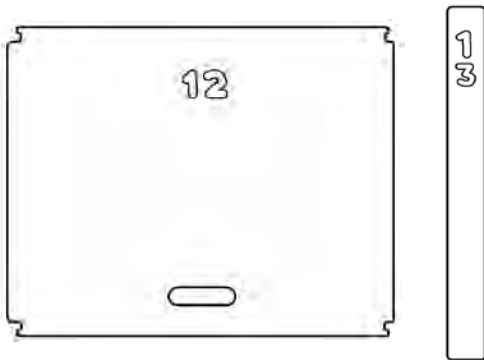

You will have wood pieces 12 and 13 left over. They will be used later on during foam and fabric assembly.

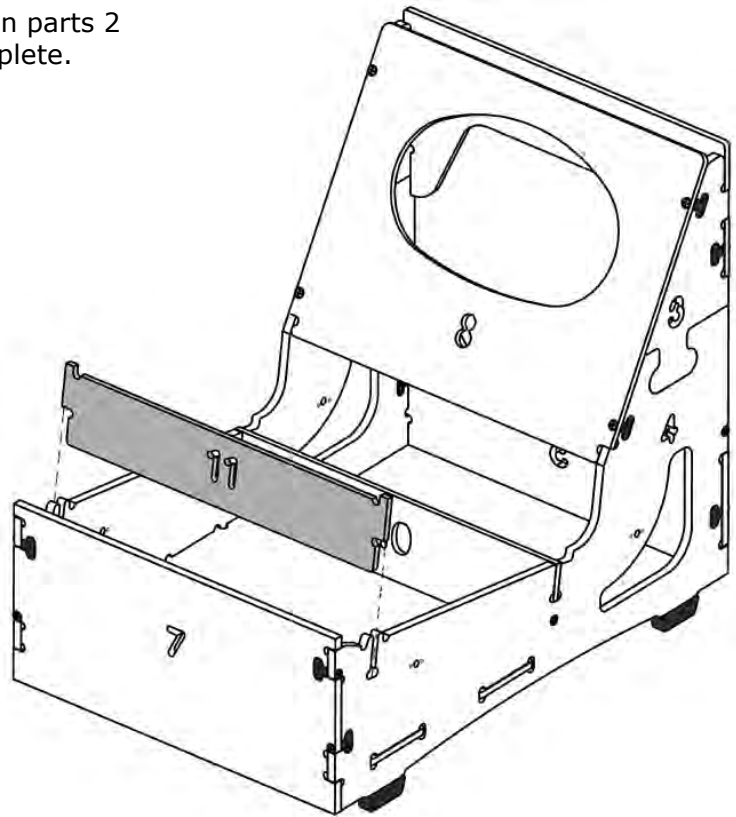

- 12** Repeat these frame assembly steps [steps 1 - 11] for box #2. You'll be making another side to the loveseat frame, an exact match to the one just completed.

Joining The Frames Together

(Arms will be added in a later step.)

Join frames together with the connector bolts from the parts bags.

There are holes for the connector bolts at the front and back of the frames as indicated by the arrows in the diagram below. Align the frames and slide the connectors into the holes. Tighten the wingnuts to draw the frames together.

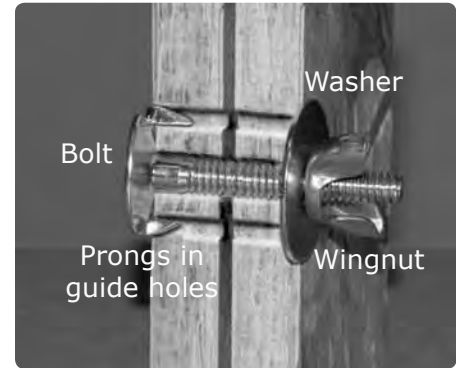

Connector Bolt

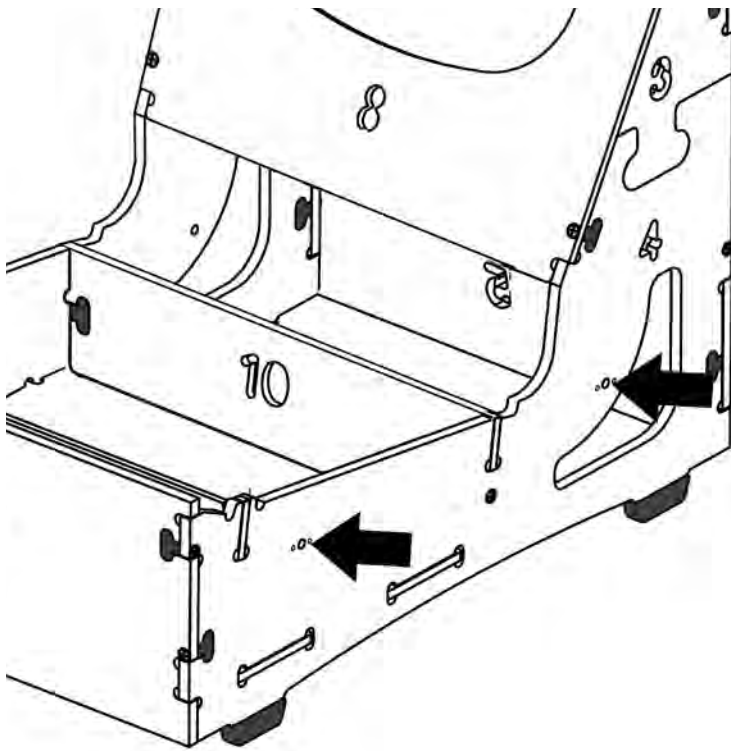

Fabric & Foam Assembly

Most of the fabric covers come inside out (It is the way they are sewn and protects the fabric surface in shipping). Unfold them all in preparation for assembly. To unfold a piece with a zipper, just pull the zipper apart as shown on the right.

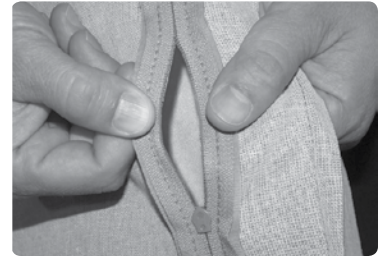

You can snip off any hanging threads from the covers. They are left long during automatic trimming in the sewing process. Snipping them won't affect the strength of the seams.

Beauty tips: In addition to these printed instructions, you may want to watch our beauty tips videos on the customer service page of the website. The videos show demonstrations on how to apply the fabric covers and make them smooth and wrinkle free.

Fabrics



End Panel Cover (2)



Seat Cushion Cover (2)



Back Cushion Cover (2)



Elite Fabric (2)



Frame Back Cover (1)



Frame Front Cover (1)

Foam



Seat Cushion (2)



Top Rail (2)



Back Cushion (2)

1 Take the two Top Rail Foam and place them on the top of the frame. Push them down into position between the front and back wood pieces.



Take the Frame front cover cover as shown above.



Insert both wood pieces 13 into the sleeve sewn into the cover... one from each end. (Use the sanding block if wood doesn't slide smoothly.)



Hold the wood firmly in place...



...and wrap the cover around the end of the wood.



...as you tuck the wood into the cover..



...on both ends.



Place the cover on the front of the frame...



...to form the front edge.



The wood piece will fit onto the frame as shown.



Put the top corners of the cover in position...



...and then pull the bottom corners of the cover around the bottom of the wood frame as shown.



Repeat the process for the other side of the frame.

4



Take the Frame Back cover and place it over the back of your frame as shown.



Pull the cover down, aligning the cover seams with the edge of the frame.



Wrap the cover around and under the back corner of the frame.



Repeat the process for the other side of the frame.

5



Tip the frame onto its back.



Reach up under the cover edge, pull out the little elastic bands...



and stretch them around the black floor glides.



There will be 2 of these elastic bands. One on the front edge cover and one on the back.



These keep the cover tight along the bottom of the frame. Return the frame to an upright position.

6



Place the cover over the end panel.



Arrange the cover so that the end panel is fully covered. It can be helpful to hold the cover as shown in the photo and shake the wood part down into position.

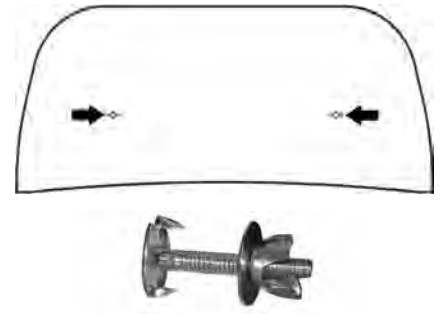

There are 2 holes in the wood which are now covered. It is through these holes you'll be placing the connector bolts in the following steps.

7



Reach inside the arm and insert the connector bolts into the holes.



The two prongs on the connector bolt go into the two small holes. This keeps the bolt from turning.



The connector bolt protrudes through the hole cut in the fabric.

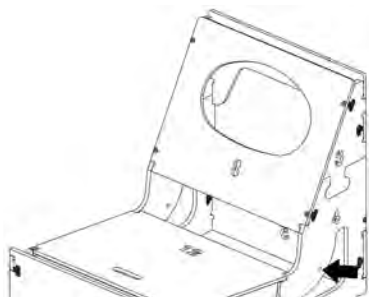

Notice the two holes in the frame through which you'll be placing the connector bolts.



With the end panel pushed against the frame, continue to insert the connector bolt through the frame as shown.



Take the washer and wingnut and get them started onto the bolt. Don't tighten completely.



Follow the steps above at the front of the panel...



...and at the back of the panel. Then tighten the wingnuts. Repeat for the other side of the frame with the other end panel.

8



Take each wood part 12 and place them into position as shown.

9

Find the Seat Cushion Covers and Seat Cushion Foams and follow the sequence below.



Match the rounded front edge of the seat cushion foam with the rounded edge of the seat cushion cover.



Position the cover over the foam and align the corners of the foam cushion with the corner seams of the cushion cover.



You can stick your hand right up in there to get everything smooth.



Working your way around the sides of the cushion pull the corners of the cover onto the foam...



...and zip up the cover.



Place the seat cushion on the frame. The rounded edge of the cushion goes toward the front.

10

Cover the back cushion with the elite fabric. The elite is a white silky material that will help you slide the cover over the foam in step 10. Without the elite the cover sticks to the foam and is hard to get into position.



Start by laying the elite over the wedge shaped area of the back cushion.



Leave enough overlap so that you can...



...wrap it up under the wedge.



Now bring it over the top of the foam...



...stretch it out wide...



...and lay it down the front of the foam.



Position the elite across the bottom...



...and then bring it back up the foam so that you finish under the wedge shaped area.



Smooth the sides and make sure all the foam is covered.

11



Take the back cushion cover and place it over the side of the elite covered back cushion foam. Start at the top corner.



Fill in the wedge shaped area and the top of the cover. You can work the materials with your hands and also reach up under the cover to smooth and straighten.



Turn the cushion over, smash down the foam and as you release it, guide the foam...



...so that it pops back up into the wedge shaped area and the top of the cover. Straighten as



Work the cover down along the sides...



...wrap the cover around the corners of the foam...



...and start zipping the cushion closed.



Zip the bottom...



...and up the other side.



Once the zipper is closed, you can work the cover with your hands to make it all fit evenly. Wide sweeping motions work better than small movements.



Make sure the cover is pressed all the way up into the wedge area.



The back cushion is now ready to be placed on the frame.



Place the back cushions on the frame.



Congratulations, assembly is now complete.

SEAT DEPTH ADJUSTMENT

The furniture was designed to allow for seat depth adjustments. The normal setting is for the cushions to protrude 1 1/2" out in front of the frame. Slide the seat cushion in or out to adjust to your own seat depth preference.

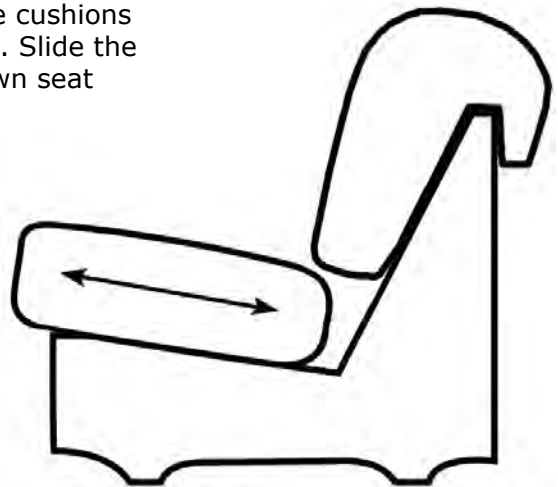

NOTE:

You can snip off any hanging threads from the covers. They are left long during automatic trimming in the sewing process. Snipping them won't affect the strength of the seams.

HOME | RESERVE

Home Reserve products are
made in the USA under patents:

#6,267,446

#6,568,058

#6,981,747

#7,044,557

#7,523,989

