



Laney couch

assembly instructions



Smooth & Wrinkle-Free Fabric Covers:

In addition to these printed instructions, you may want to watch our beauty tips videos on the customer service page of our website. The videos show demonstrations on how to apply the fabric covers and make them smooth and wrinkle free.



Renewability: Individual foam and fabric parts are available. You no longer have to worry that something will happen and you'll just have to live with it. From pet attacks to paint spills, it's easy to recover from a furniture accident.

CUSHIONS

Foam: The seat cushions will feel firm at first. That's intentional, since firmer foam lasts longer. You can shorten the break-in period by putting the cushions on the floor and walking on them for a few minutes.



Fabric Exchange: To use our 30-day fabric cover exchange program, contact us and we'll lead you through the process. Keep the covers out of actual use to preserve them in new, unused, and clean condition. Fold them neatly when repackaging to avoid wrinkles.

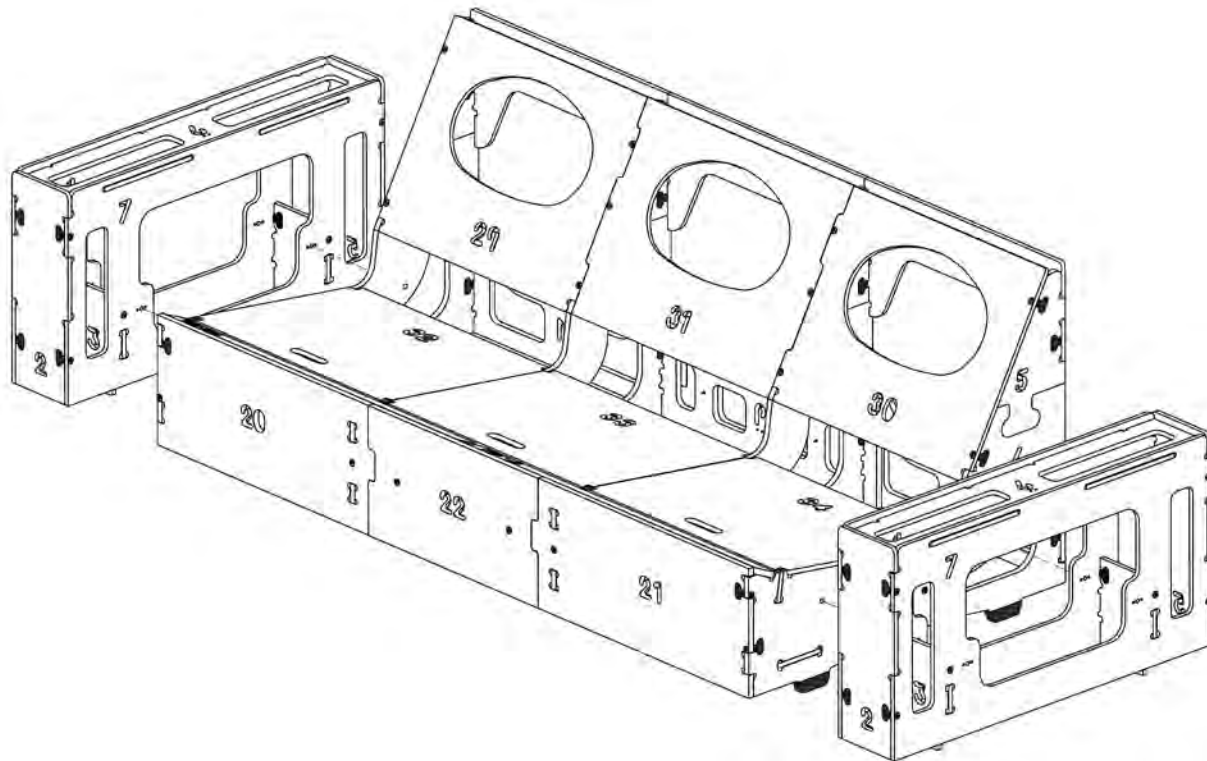

Tools: Phillips screwdriver or powered drill with a Phillips screwdriver bit.

A sanding pad is included if you wish to smooth over any of the surfaces or edges after the frame is assembled. It is not necessary to sand any of the frame parts during assembly. No glue will be used. Your furniture will be ready for use immediately.

Arm Assembly

Open the boxes and set aside the foam and fabric for later. Leave the wood parts in the boxes. We will take them out as needed.

- 1** Take wood parts 1-7 out of box 1. Open the parts bag and insert the black plastic T-connectors into the parts shown here. Throughout these instructions it is okay to use a hammer to tap the T-connectors and wood parts into position.

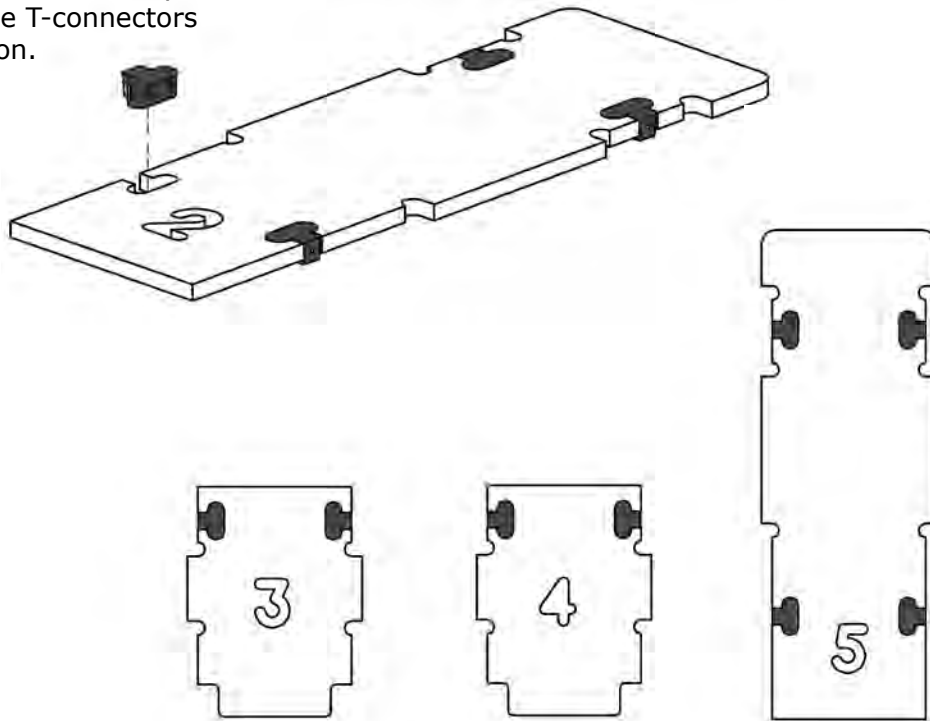

- 2** Connect parts 1 and 2 together and secure with two screws.

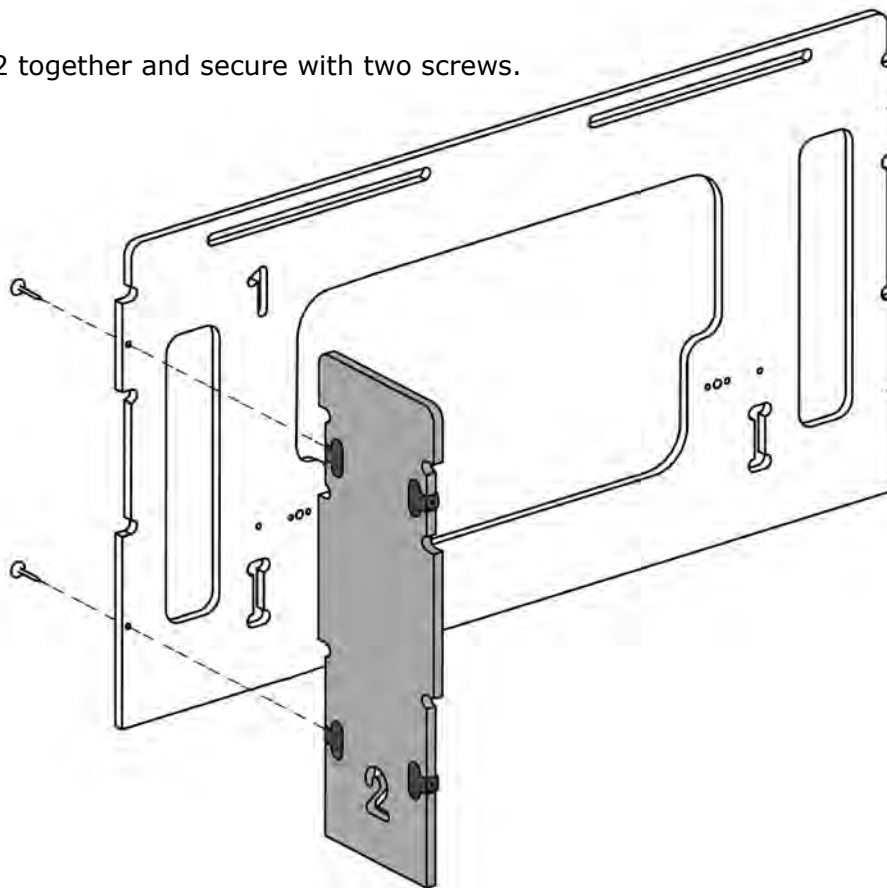

3 Place part 3 into position on part 1 and secure with a screw.

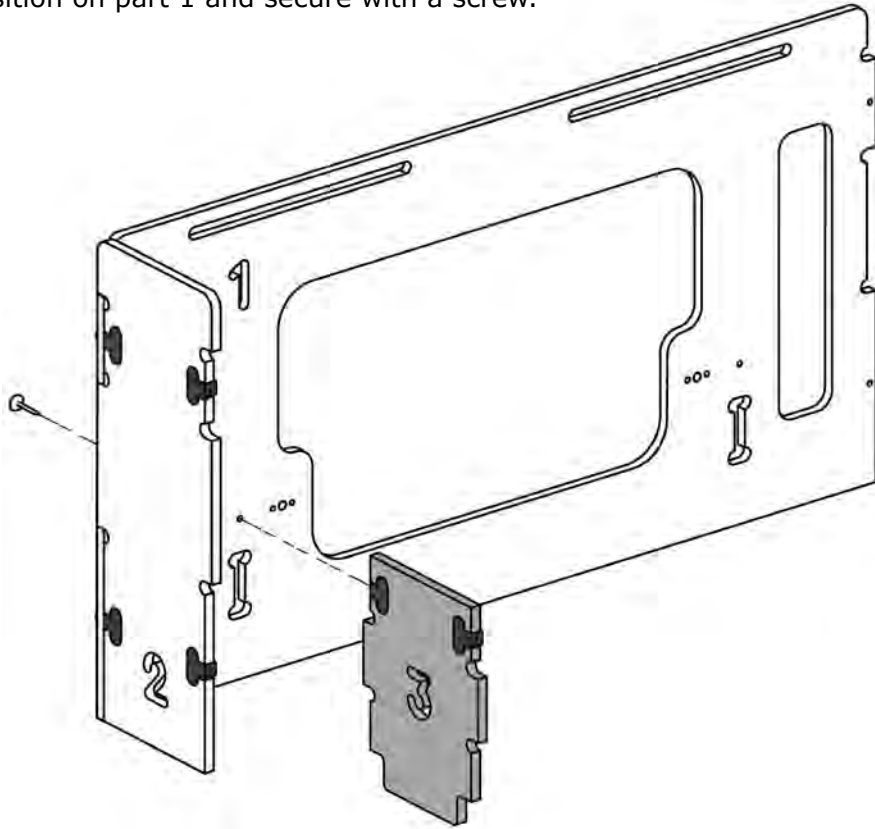

4 Place part 4 into position on part 1 and secure with a screw.

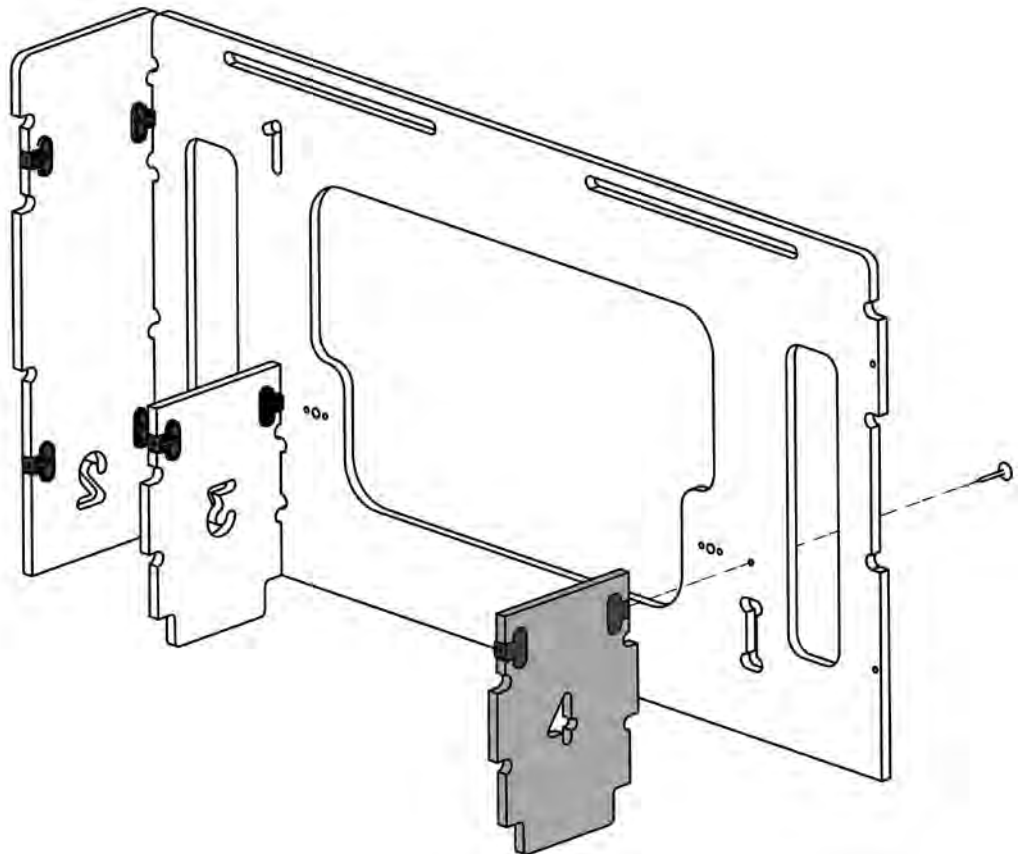

5 Connect parts 5 and 1 together and secure with two screws.

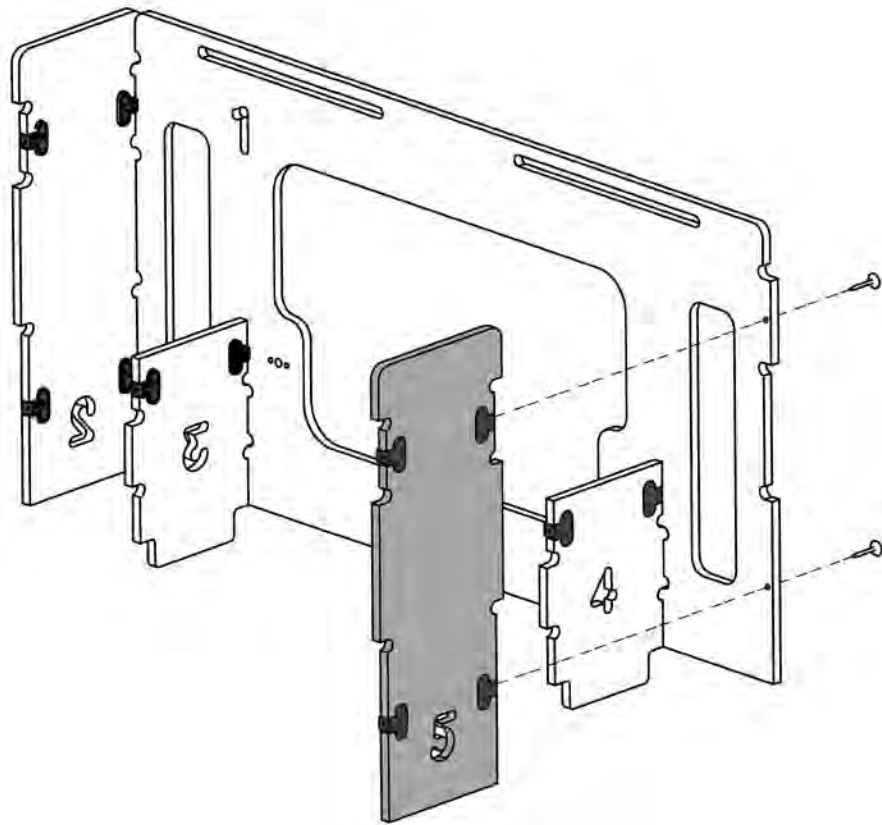

6 Place part 6 into position as shown.

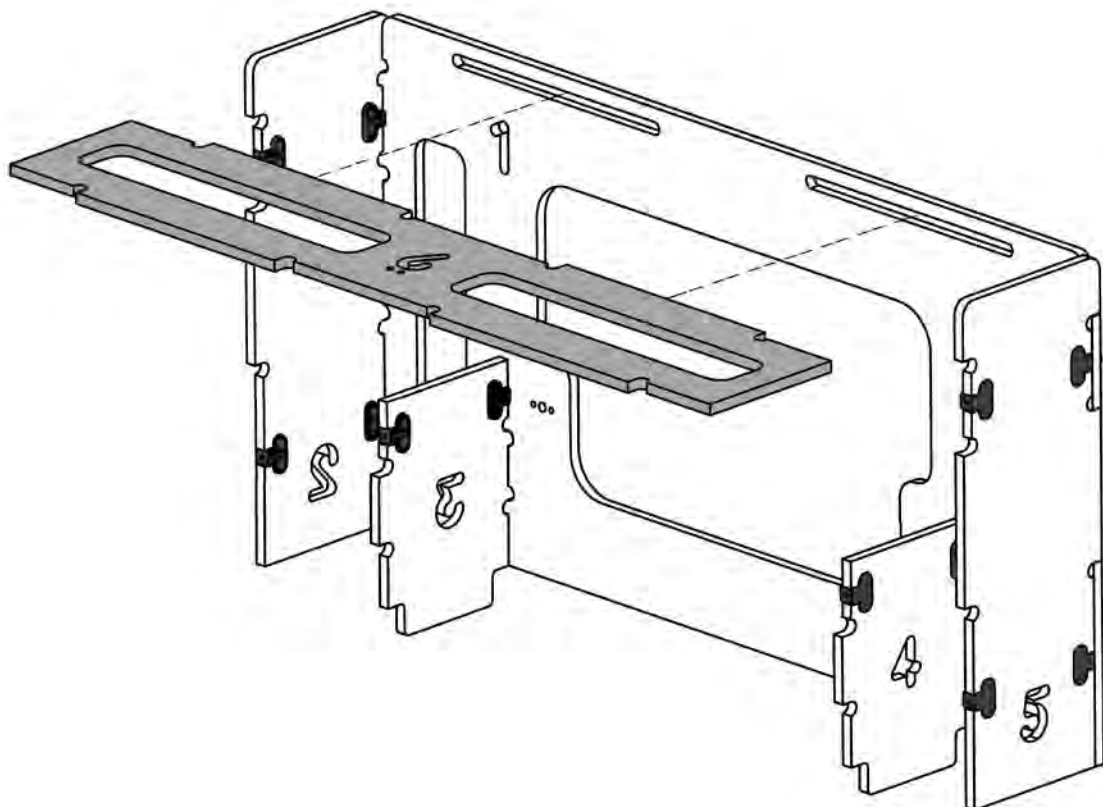

7

While holding part 6 in place, put part 7 into position on parts 2,3,4,5, and 6, then secure with six screws.

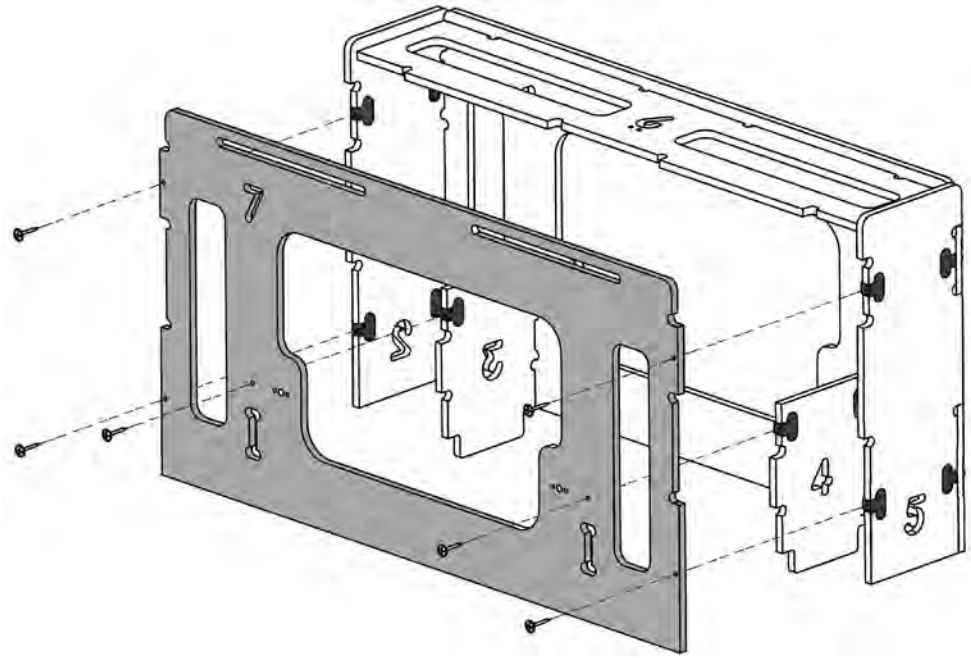

8

Repeat the assembly process for the other arm. There will be another set of wood parts numbered 1-7. Take them out of the box and follow these same steps (1-7). Set the arms aside when finished.

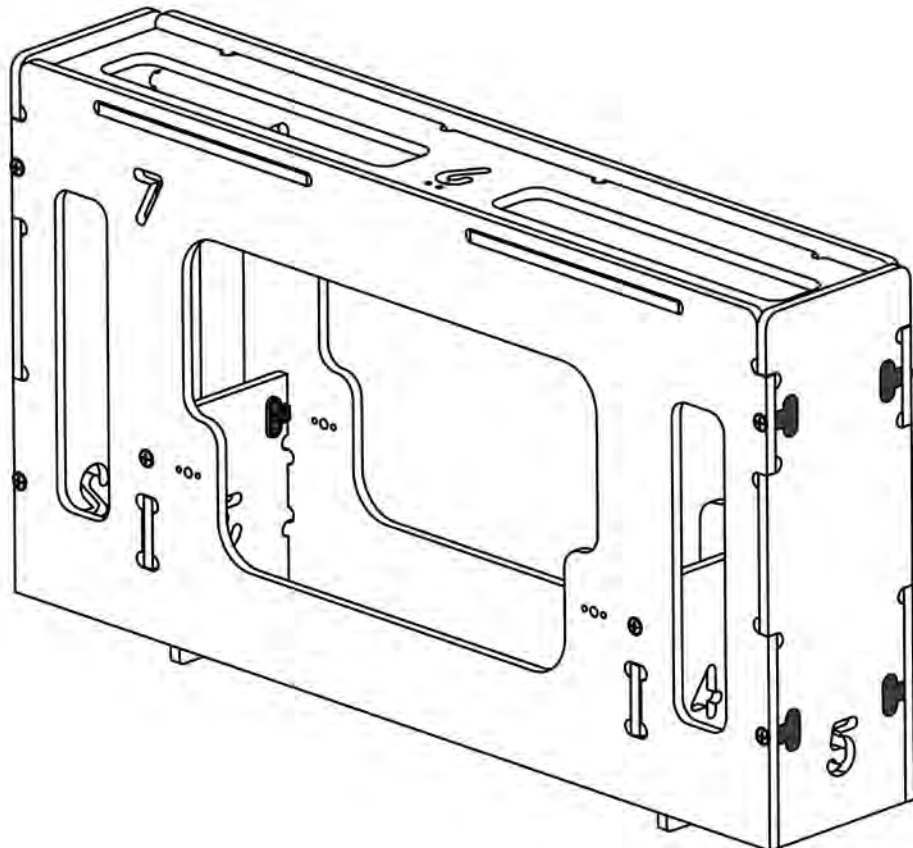

Frame Assembly

Now take all the remaining wood parts out of both boxes. These parts are not packed in order of assembly so don't worry about mixing them. They are all numbered for easy reference.

- 1** Insert the black plastic T-connectors into the parts shown here. Throughout these instructions it's okay to use a hammer to tap the T-connectors and wood parts into position.

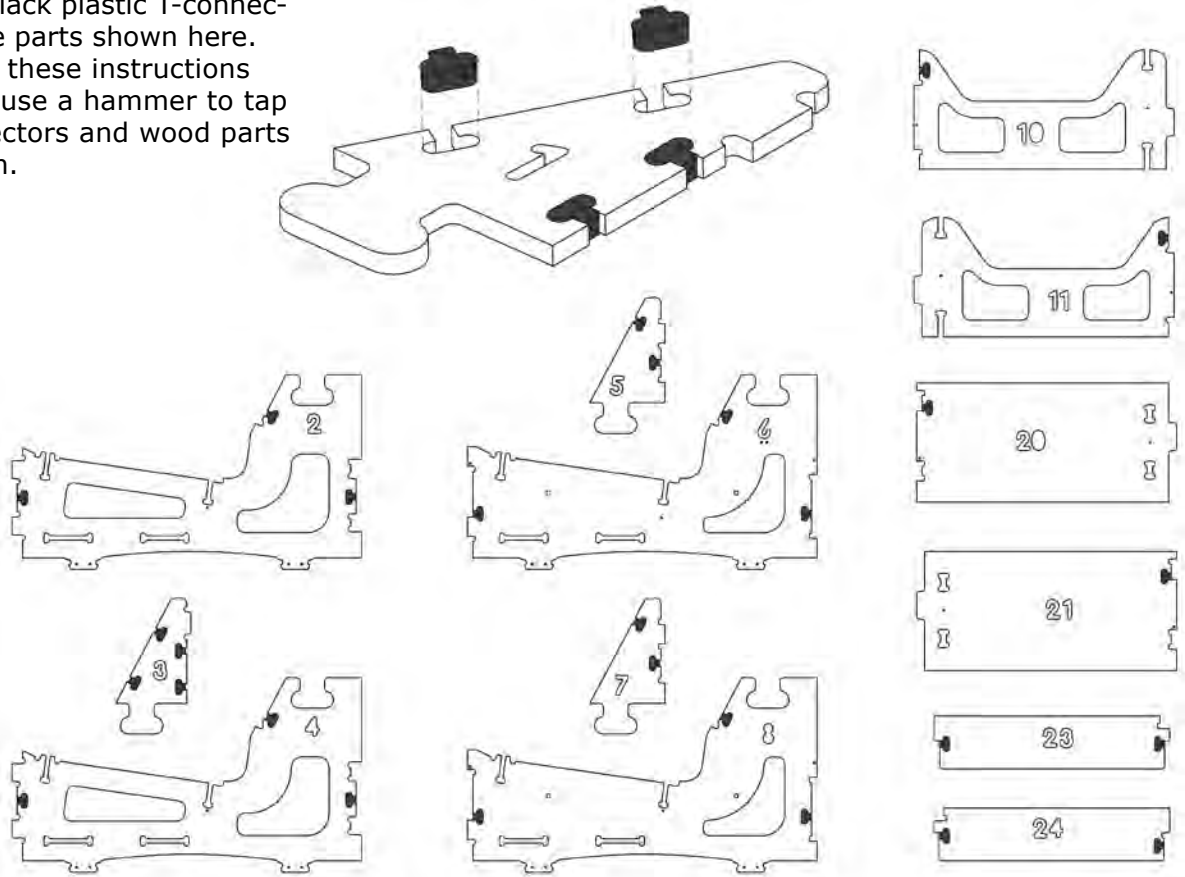

- 2** Attach black floor glides to the parts shown.

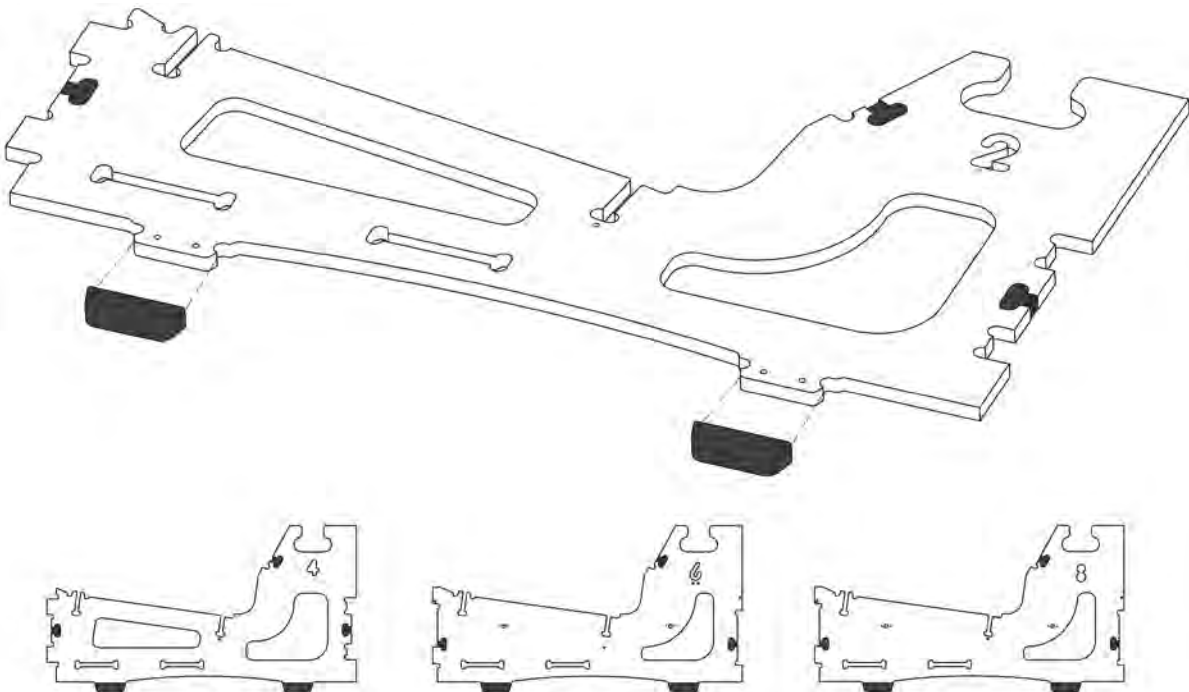

3

Connect parts 1 and 2 together. Repeat for parts 3 and 4, 5 and 6, 7 and 8.

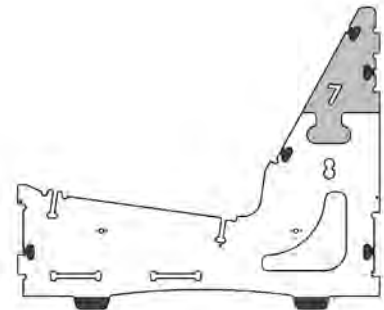
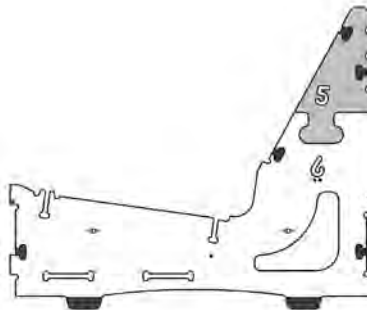
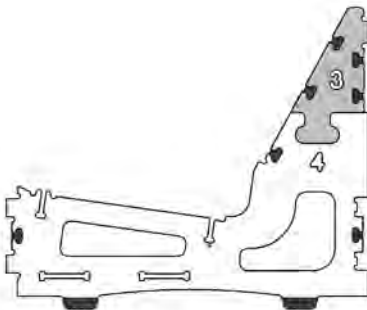
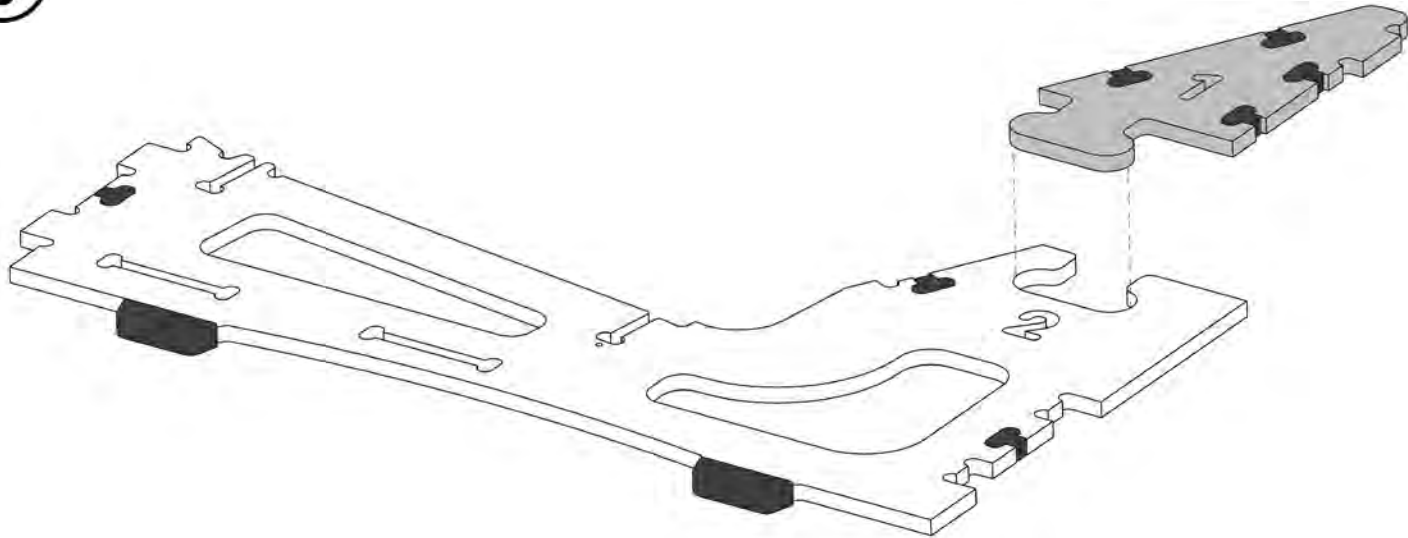

4

Slide part 9 onto parts 4 and 2. No screws are used in this step.

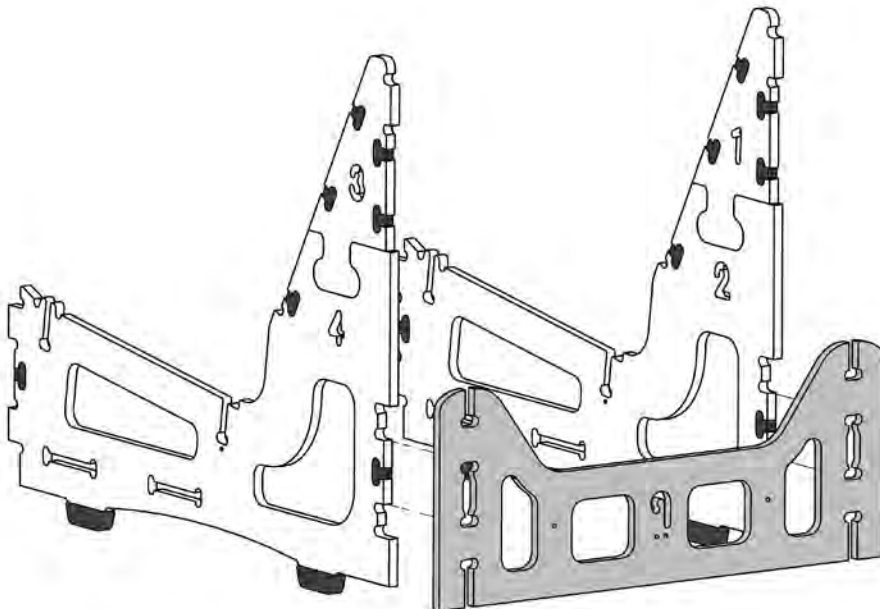

detail enlarged
for clarity

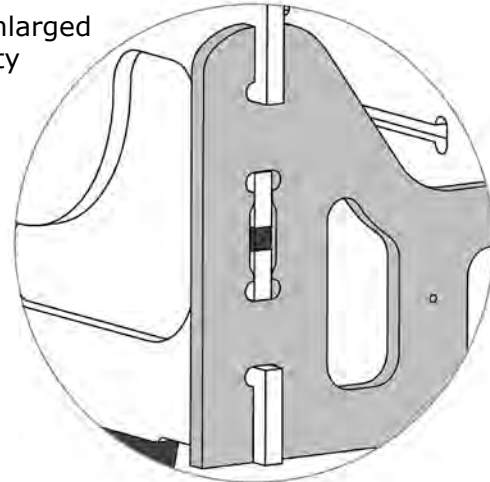

- 5** Move part 10 into position overlapping part 9 and secure with a screw (make sure screw aligns with the hole in the T-connector on part 4). Move part 11 into position on the other side and secure with a screw.

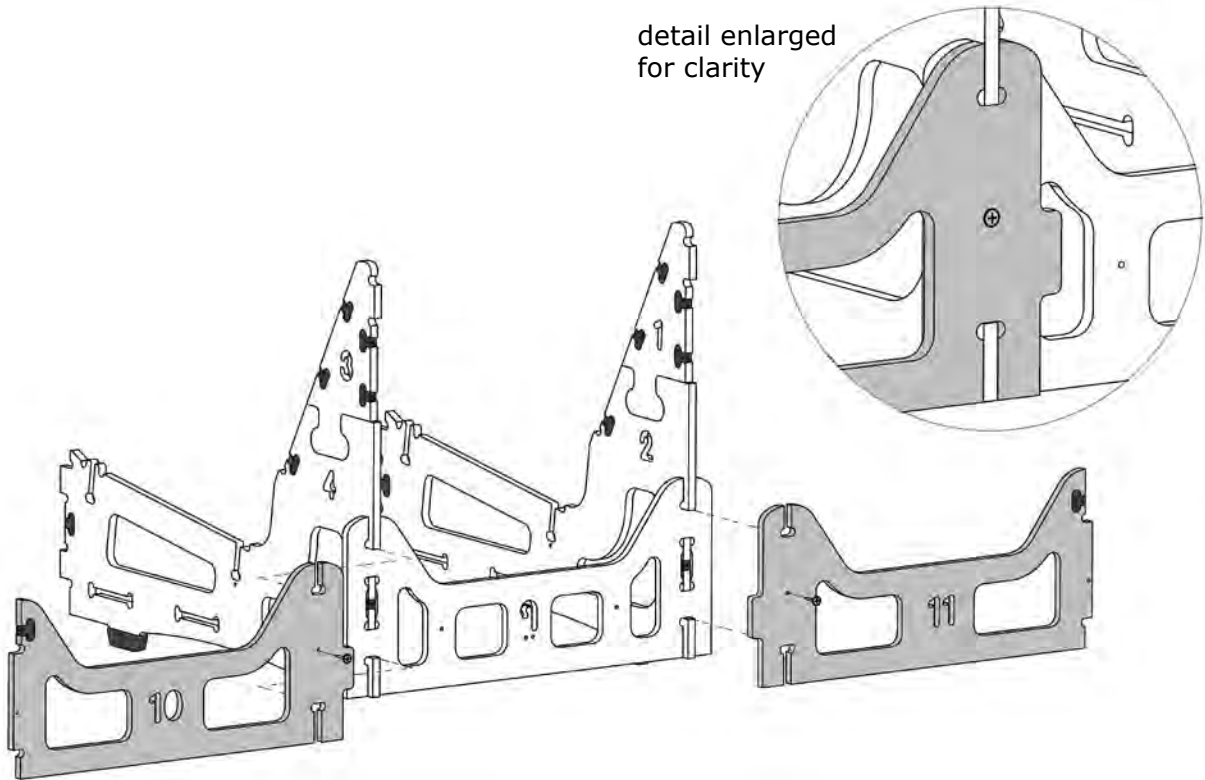

- 6** Align part 12 over part 9 and secure with two of the special-size screws. The special-size screws for this step are in a small plastic bag labeled "For use with parts #12 and #22." These screws are slightly smaller so that they don't protrude.

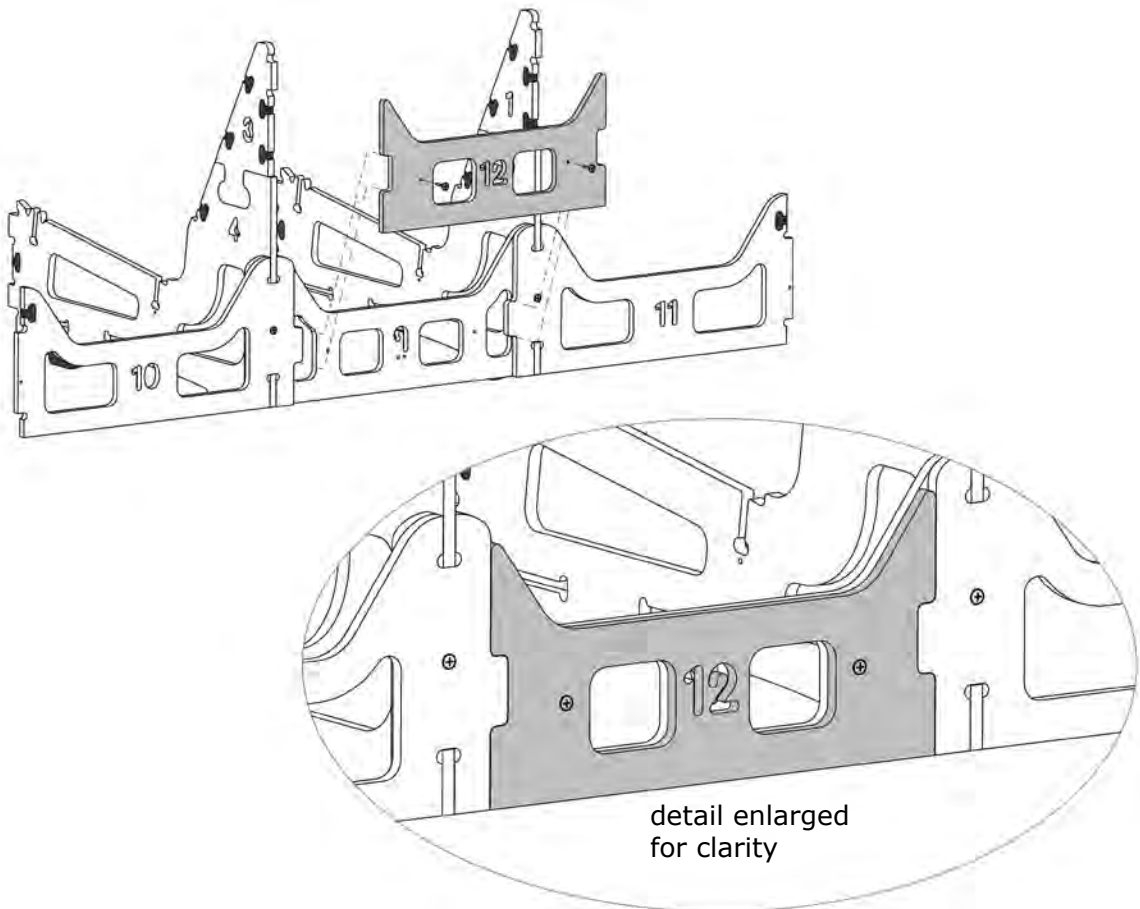

- 7** Slide part 6 into position on part 10 and secure with two screws. Repeat the process for parts 8 and 11.

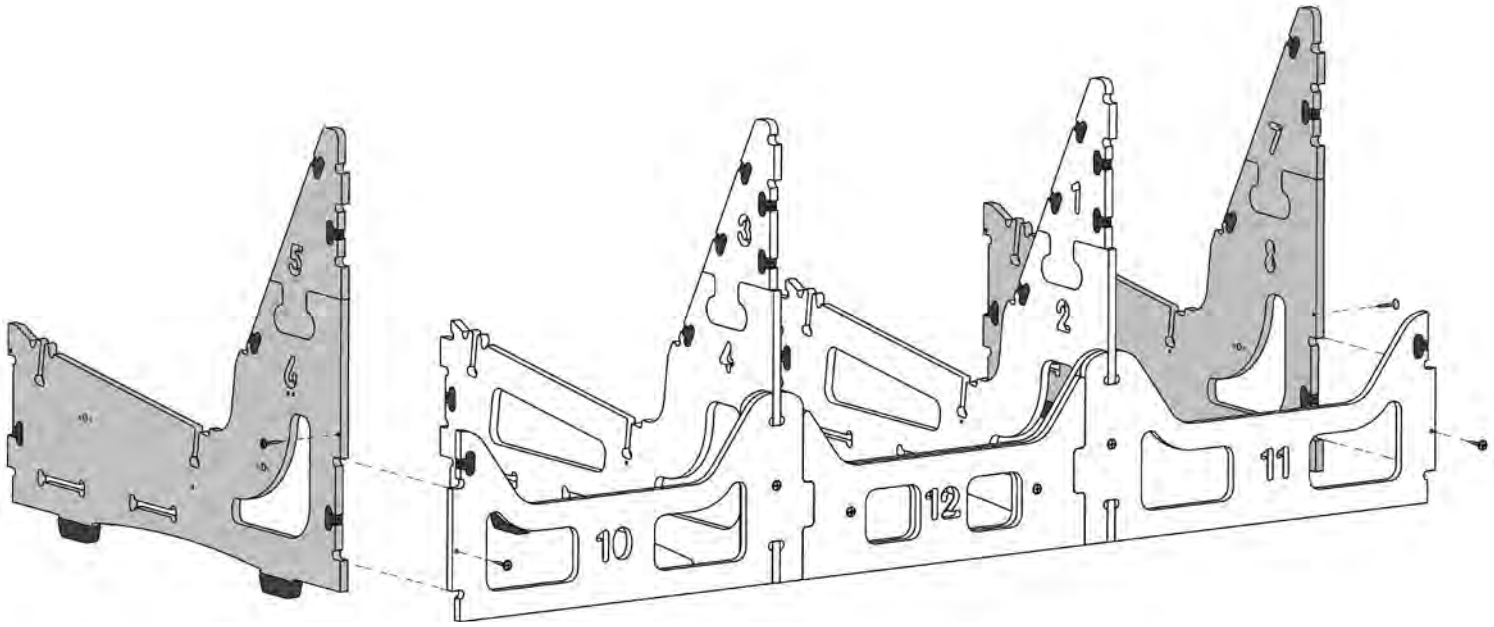

- 8** Align part 13 onto parts 5 and 3, then secure with two screws. Align part 14 onto parts 1 and 7, and secure with two screws. Move part 15 into position between 13 and 14. Secure with two screws.

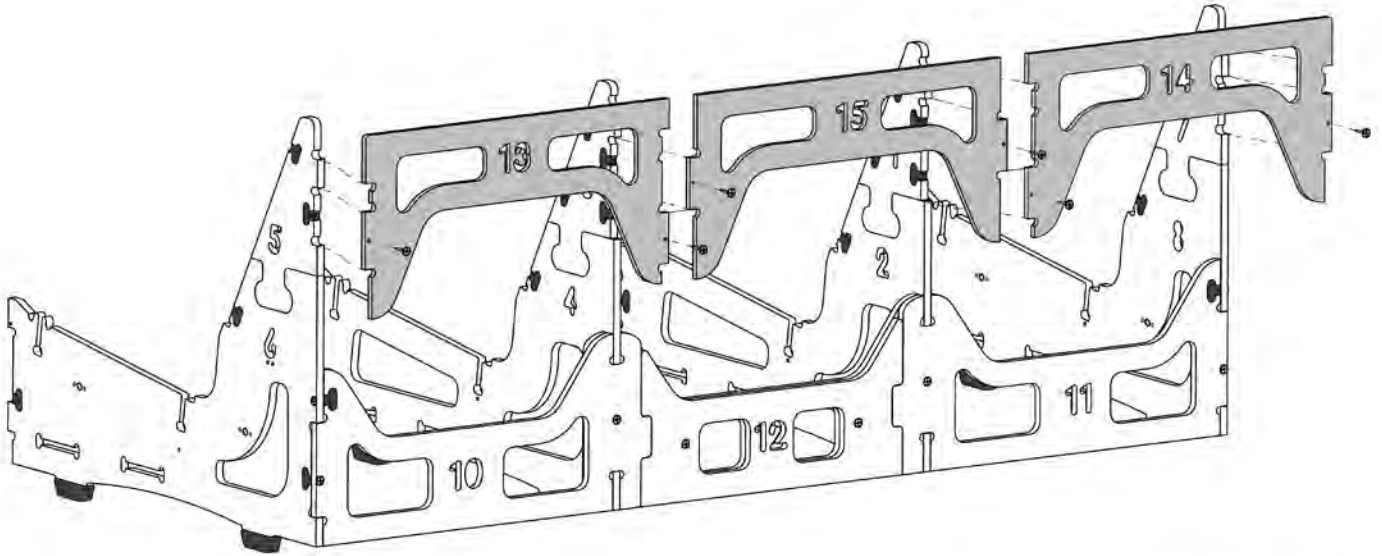

detail enlarged
for clarity

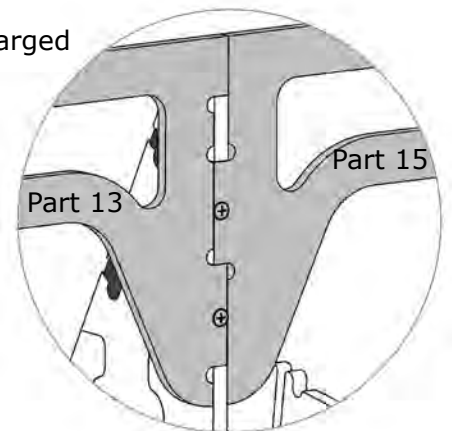

- 9** Spread parts 2 and 4 apart enough to slide part 16 into the slots on 2 and 4 (refer to Top View A below). Move part 8 out far enough to slide part 17 into the appropriate slots on 2 and 8 (refer to Top View B below). Follow the same procedure with part 18 on parts 4 and 6.

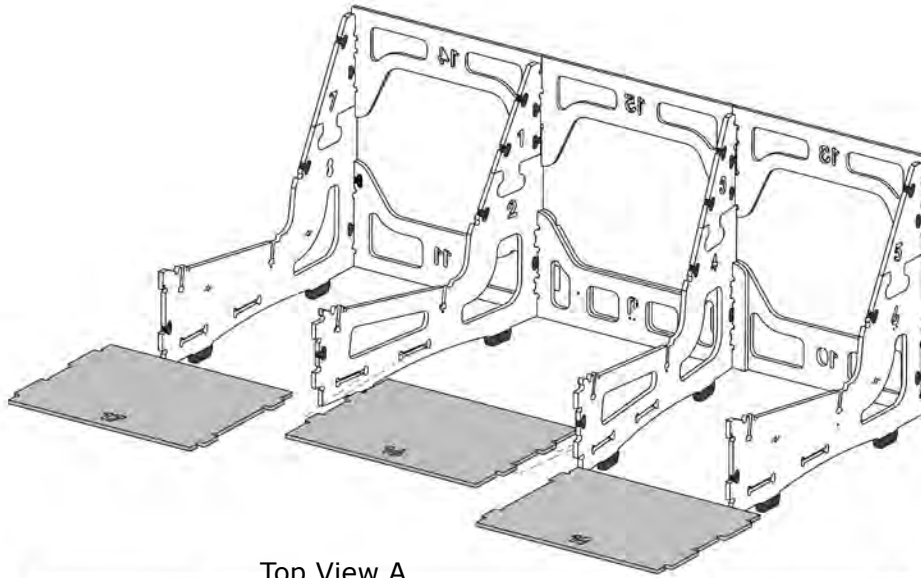

Top View A

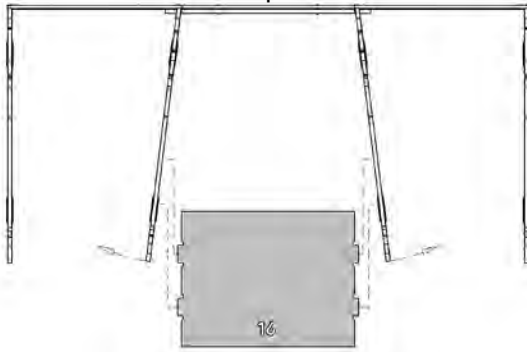

Top View B

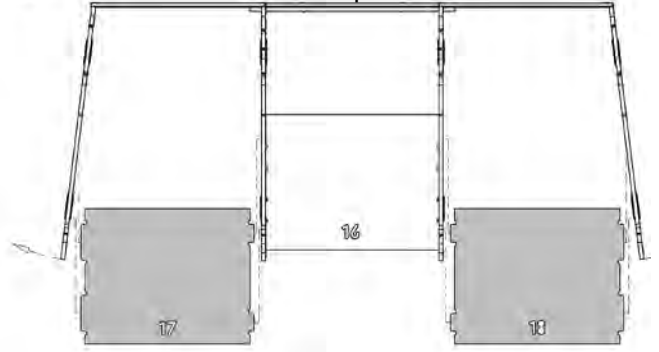

- 10** Slide part 19 onto parts 2 and 4. No screws are used in this step.

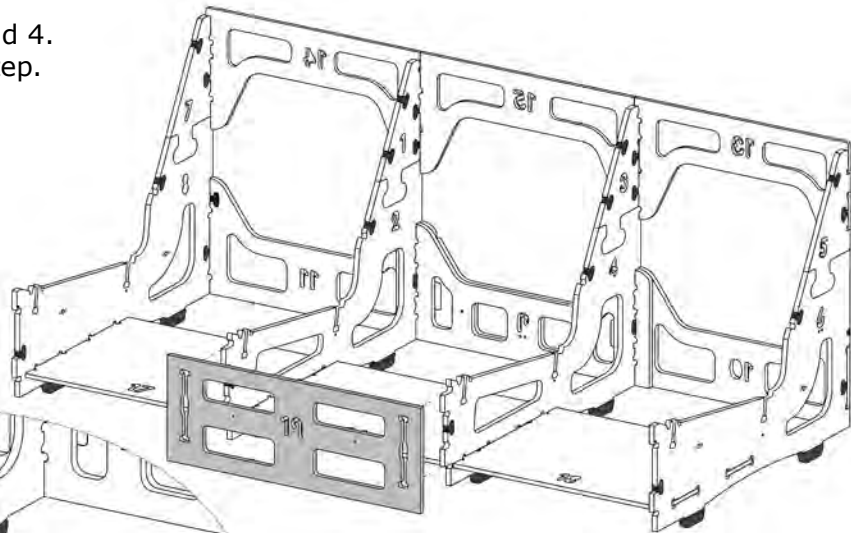

detail enlarged
for clarity

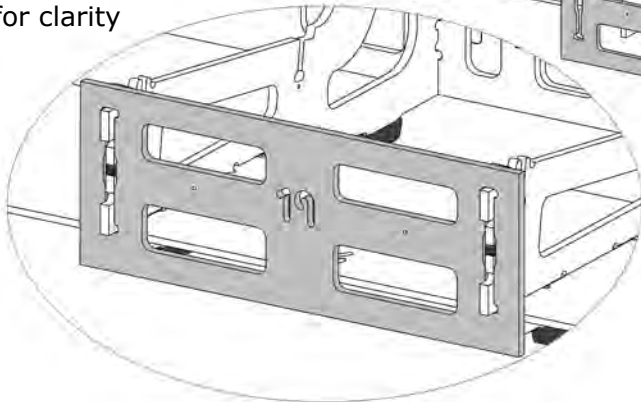

- 11** Move part 20 into position overlapping part 19 and connecting onto part 8, then secure with three screws. Repeat process for part 21 on the other side.

detail enlarged
for clarity

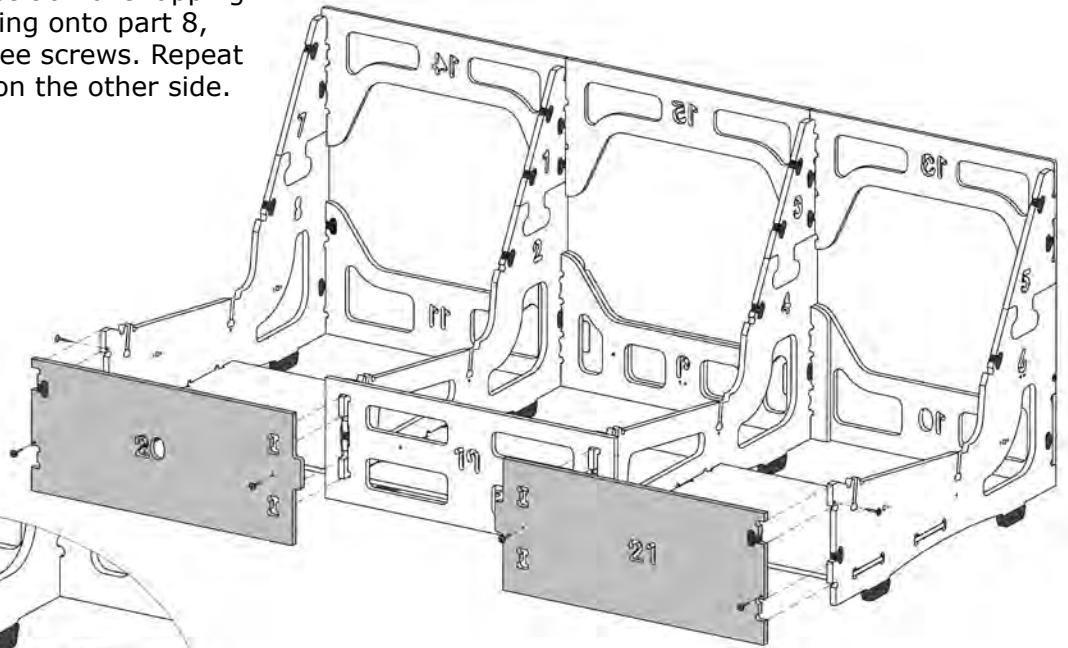
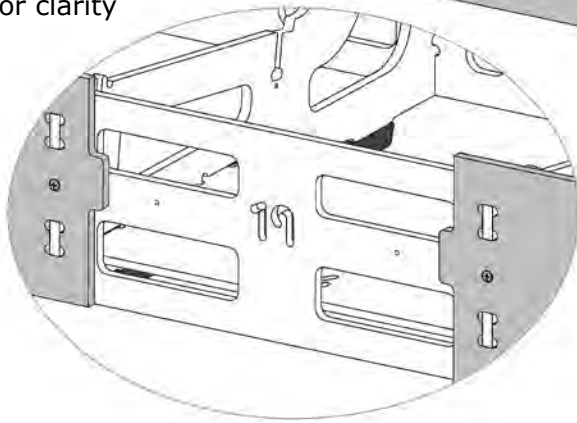

- 12** Align part 22 over part 19 and secure with two of the special-size screws. The special-size screws for this step are in a small plastic bag labeled "For use with parts #12 and #22." These screws are slightly smaller so that they don't protrude.

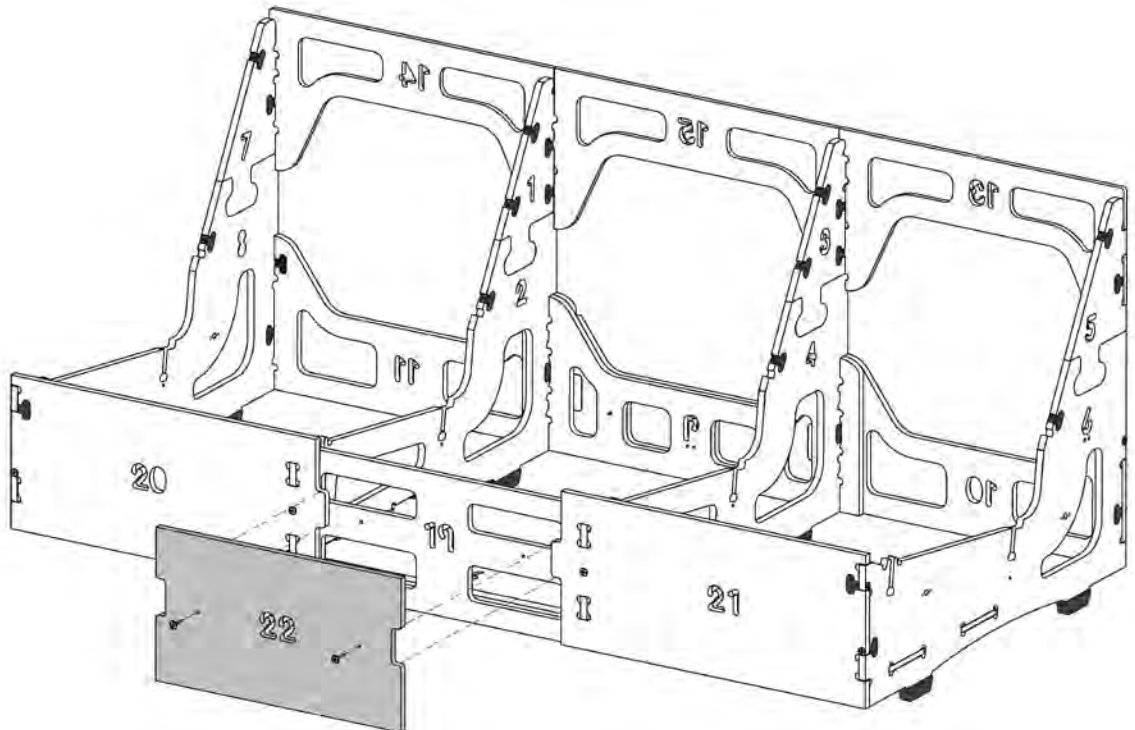

- 13** Slide part 23 into the back slots of parts 8 and 2 and secure with two screws. Slide part 24 into the back slots of parts 4 and 6 and secure with two screws. Part 25 slides down into position between 23 and 24.

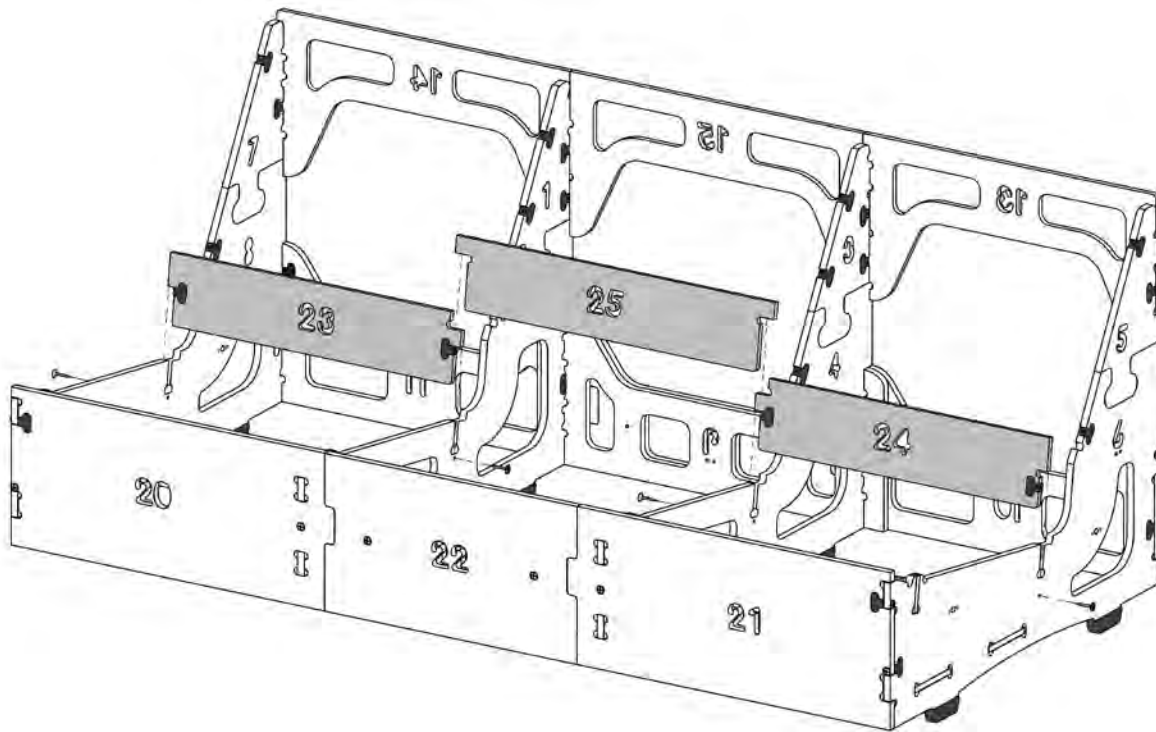

- 14** Work from left to right sliding parts 26, 27, and 28 into the slots near the front of the frame.

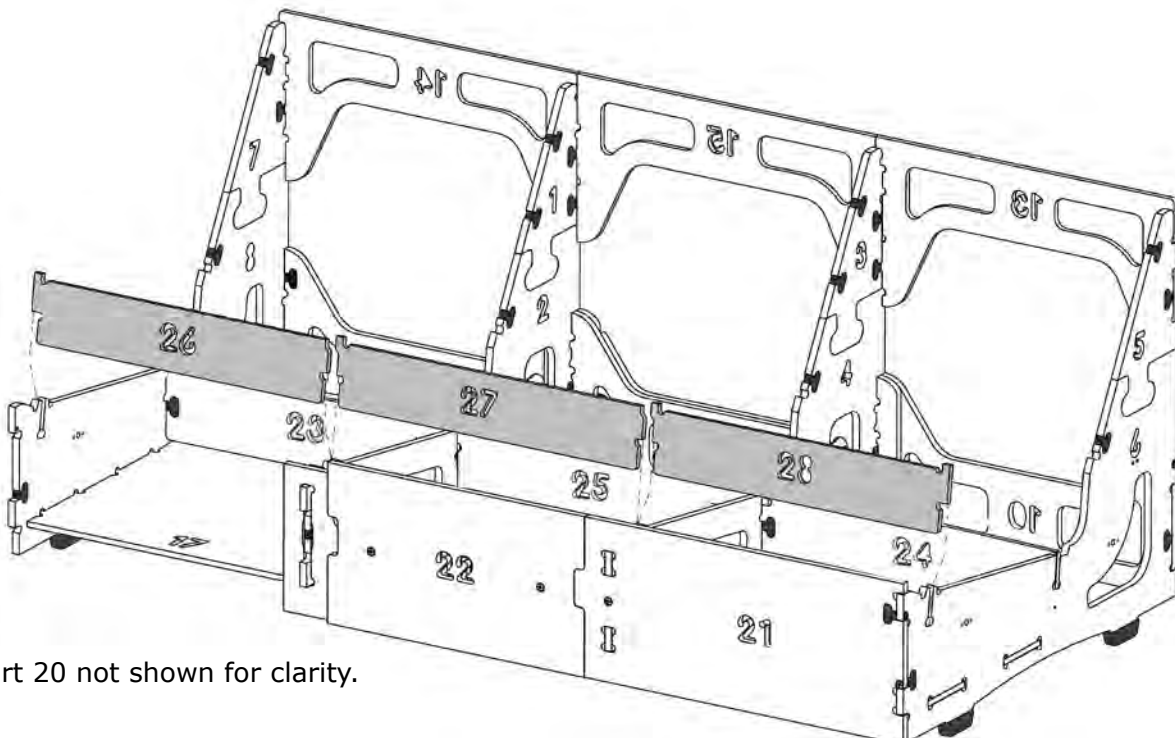

Part 20 not shown for clarity.

15

Move part 29 into position and secure with four screws. Repeat for part 30. Move part 31 into position between 29 and 30, then secure with screws.

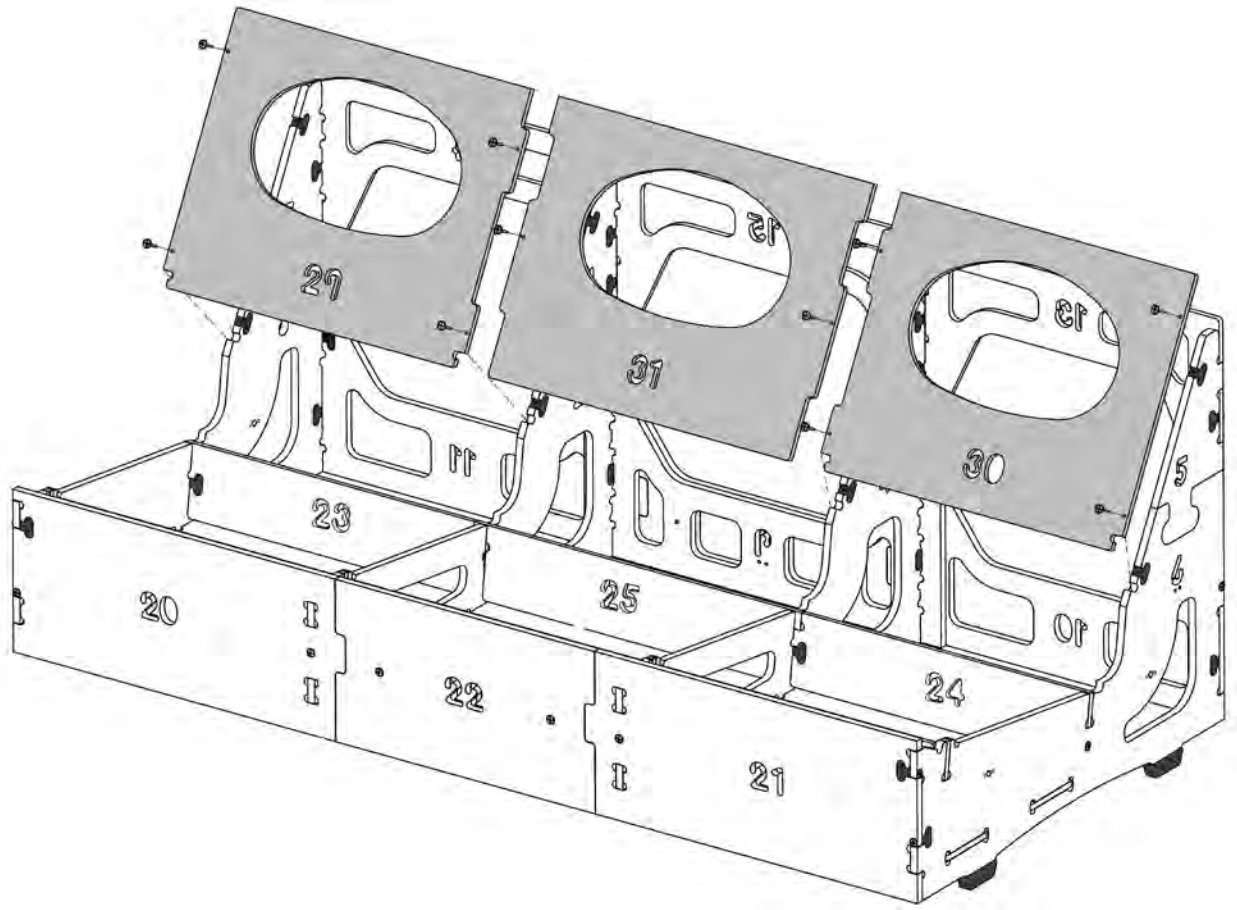

Frame assembly now complete. You will have wood pieces 32,33,34,35, and 36 remaining. They will all be used later during fabric and foam assembly.

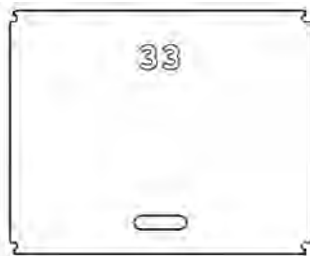

Fabric & Foam Assembly

Most of the fabric covers come inside out (it is the way they are sewn and protects the fabric surface in shipping). Unfold them all in preparation for assembly. To unfold a piece with a zipper, just pull the zipper apart as shown on the right.



You can snip off any hanging threads from the covers. They are left long during automatic trimming in the sewing process. Snipping them won't affect the strength of the seams.

Beauty tips: In addition to these printed instructions, you may want to watch our beauty tips videos on the customer service page of the website. The videos show demonstrations on how to apply the fabric covers and make them smooth and wrinkle free.

Fabrics



Frame Back Cover (1)



Seat Cushion Cover (3)



Back Cushion Cover (2)



Middle Back Cushion Cover (1)

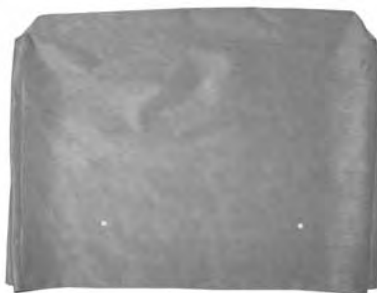

Arm Cover (2)



Frame Front Cover (1)

Foam



Seat Cushion (3)



Top Rail Piece (3)



Back Cushion (2)



Middle Back Cushion (1)



Arm Foam (2)

1

Take the three Top Rails and place them on the top of the frame. Push them down into position between the front and back wood pieces.



2



Take the Frame Front Cover as shown above.



Insert wood piece 35 all the way into the sleeve.



Hold the wood firmly in place...



... and wrap the cover around the end of the wood...



... as you tuck the wood into the cover.



Repeat this process with wood piece 36 at the other end of the cover.

3



Place the cover on the front of the frame...



... to form the front edge.



The wood piece fits onto the frame as shown.



Put the top corners of the cover in position...



... and then pull the bottom corners of the cover around the bottom of the wood frame.



Repeat this process on the other side of the frame.

4



Take the Frame Back Cover (it's the largest fabric piece) and place it over the back of the frame as shown.



Pull the cover down, aligning the cover seams with the edge of the frame.



Wrap the cover around and under the back corner of the frame.



Repeat the process for the other side of the frame.

5



Roll the frame onto its back.



Reach up under the cover edge and pull out the little elastic bands...



Stretch them around the black floor glides.



There are four of these elastic bands. Two on the Frame Front Cover and two on the Frame Back Cover.



These keep the covers tight along the bottom of the couch. Leave the frame on its back and move to the next steps.

6



Position the Arm Foam onto the arm frame.



The bottom of the foam is recessed in order to fit onto the arm frame.

7

The Arm Covers will fit snugly in the following sequence. The trick is to work them down the frame very gradually—inch by inch, as shown in the photos below—making equal progress on both sides.

Be sure to visit the beauty tips video page (www.homerreserve.com/BeautyTips.cfm). You can see a demonstration of this process, and other tricks that will keep your furniture looking beautiful.



Take the Arm Cover...



... and place it over the foam and frame.



Align the seams with the edges of the wood arm frame and pull the cover down an inch or two onto the frame.



Then, position the cover and seams over the other end of the arm frame and work it down slightly.



Now that you have the cover positioned onto the frame at both sides, you can begin to work the cover all the way down...



... aligning the cover seams with the edge of the frame and alternately pulling each side so that neither one gets too far ahead of the other.



Once the Arm Cover is in place, smooth and straighten the fabric.



Flip the arm over to access the velcro attachments.



Starting with the flaps in the middle, draw the sides of the arm taut by pulling up on the fabric, folding the flaps over...



... and securing the velcro together...



Follow the same procedure for the flaps at both ends of the arm.



Complete the final step on the ends by folding over the front flap and securing the velcro.



Once the Arm Cover is in place, smooth the fabric. Reposition the velcro flaps on the bottom of the arm, if necessary, to take out any wrinkles. Repeat these steps for the other arm unit.

8

In these next steps we'll be joining the arms to the frame with the connector bolts. See the diagram on the right.

There are holes for the connector bolts at the front and back of the frame as indicated by the arrows below.

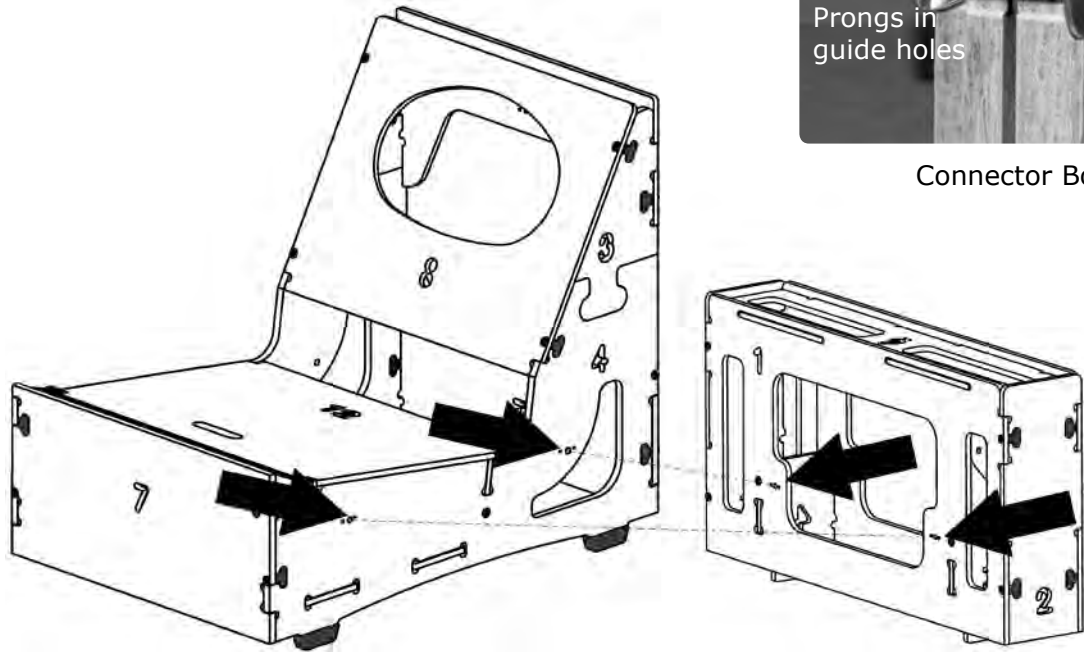

The frame should be on its back from step 5. Now, turn the arms over as well. Notice the holes in the arm fabric...



... and align them against the frame.



Follow the next steps to attach the connector bolt at the back of the frame (the hole closest to the floor with the frame on its back).



Reach inside the arm and insert the connector bolt into the hole.



The two prongs on the connector bolt go into the two small holes. This keeps the bolt from turning.



The arm is moved away from the frame in this photo to show how the connector bolt protrudes through the circular hole cut in the fabric.



With the arm pushed against the frame, insert the connector bolt through the frame as shown.



Take the washer and wingnut and get them started onto the bolt. Don't tighten completely.



Now put the connector bolt that goes toward the front of the frame into place.



You may need to stand up and reach over the front rail in order to improve visibility and complete installation of the washer and wingnut.



Once the connector bolts are in position at both front and back, tighten the wingnuts to draw the frames together.

9



Turn the frame upright. Take wood part 32 and place it into position at the left end of the frame.



Take wood part 33 and place it into position in the middle of the frame.



Take wood part 34 and place it into position at the right end of the frame.

10

Find the Seat Cushion Covers and Seat Cushion Foams and follow the sequence below.



Match the rounded front edge of the Seat Cushion Foam with the rounded edge of the Seat Cushion Cover.



Position the cover over the foam and align the corners of the foam cushion with the corner seams of the cushion cover.



You can stick your hand inside to get everything smooth.



Working your way around the sides of the cushion, pull the corners of the cover onto the foam...



... and zip up the cover.



Place the seat cushions on the frame. The rounded edge of the cushion goes toward the front.

11

Find the Back Cushion Covers and the dacron-filled Back Cushions and follow the sequence below.



When filling the covers, match up the rounded corners of the back cushions with the rounded corners of the covers.



Push the filler into the cover. You can reach inside to fill out the corners.



Zip up the cover.



You can knead the cushion on the floor to straighten and smooth it out.



You can further straighten and smooth the back cushion by striking it on the floor with several good whoops.



Change ends of the cushion and repeat.



This is also how to "fluff" the cushions in the future.



Place the back cushions on the frame.



Congratulations, assembly is complete.

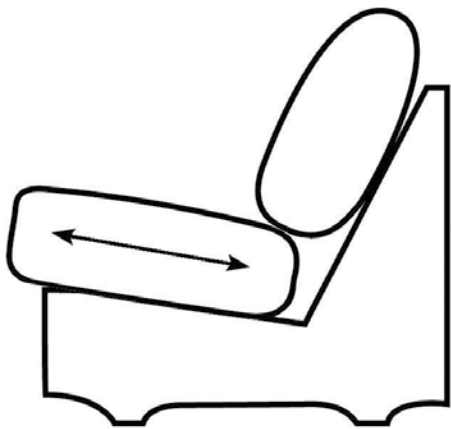

SEAT DEPTH ADJUSTMENT

The furniture is designed to allow for seat depth adjustments. The normal setting for the cushions to protrude is 1½" out in front of the frame. Slide the seat cushion in or out to adjust to your own seat depth preference.



REMEMBER

You can snip off any hanging threads from the covers. They are left long during automatic trimming in the sewing process. Snipping them won't affect the strength of the seams.

Home Reserve products are made in the USA under patents:

#6,267,446

#6,568,058

#6,981,747

#7,044,557

