



Armless

Tightback chair

assembly instructions





Smooth & Wrinkle-Free Fabric Covers:

In addition to these printed instructions, you may want to watch our beauty tips videos on the customer service page of our website. The videos show demonstrations on how to apply the fabric covers and make them smooth and wrinkle free.



Renewability: Individual foam and fabric parts are available. You no longer have to worry that something will happen and you'll just have to live with it. From pet attacks to paint spills, it's easy to recover from a furniture accident.

CUSHIONS

Foam: The seat cushions will feel firm at first. That's intentional, since firmer foam lasts longer. You can shorten the break-in period by putting the cushions on the floor and walking on them for a few minutes.



Fabric Exchange: To use our 30-day fabric cover exchange program, contact us and we'll lead you through the process. Keep the covers out of actual use to preserve them in new, unused, and clean condition. Fold them neatly when repackaging to avoid wrinkles.

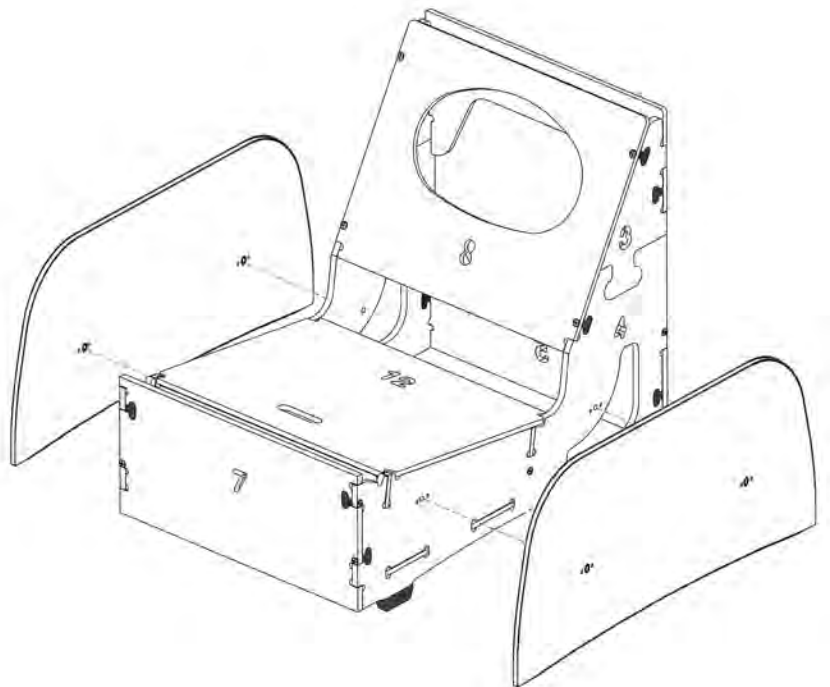

Tools: Phillips screwdriver or powered drill with a Phillips screwdriver bit.

A sanding pad is included if you wish to smooth over any of the surfaces or edges after the frame is assembled. It is not necessary to sand any of the frame parts during assembly. No glue will be used during assembly. Your furniture will be ready for use immediately.

Frame Assembly

Open the box and set aside the foam and fabrics for later. Take the wood parts out of the box. These parts are not packed in order of assembly, so don't worry about mixing them. They are all numbered for easy reference.

- 1** Insert the black plastic T-connectors into the parts shown here. Throughout these instructions it's okay to use a hammer to tap the T-connectors and wood parts into position.

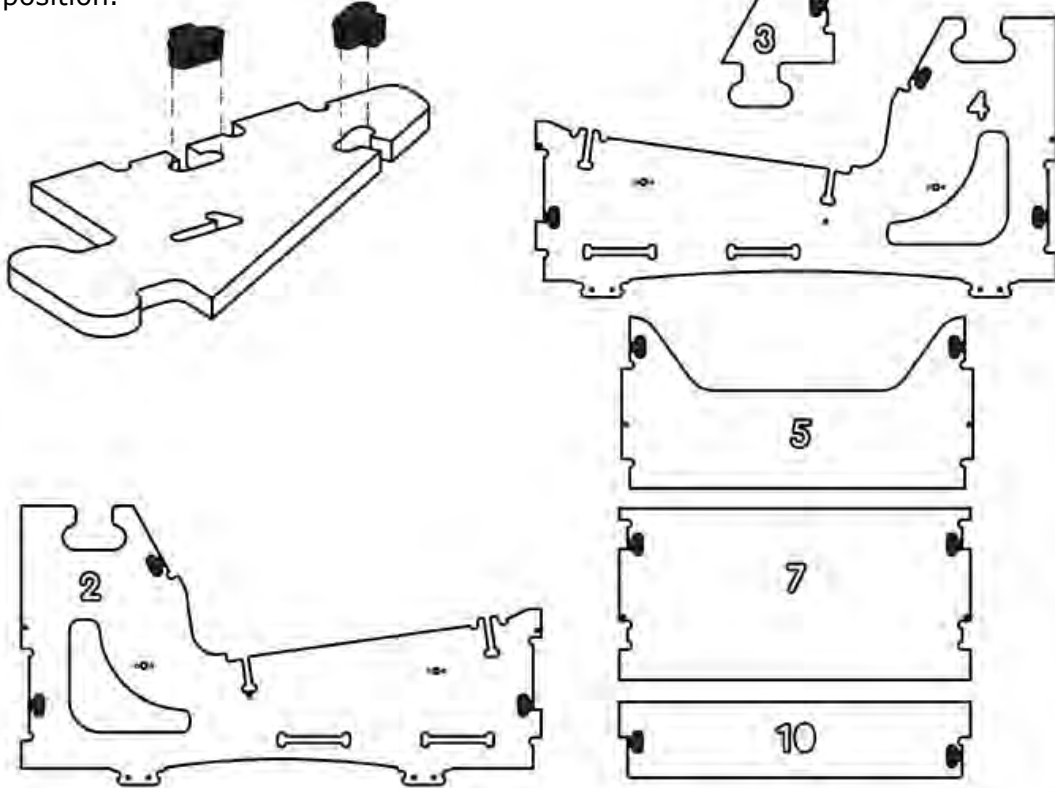

- 2** Attach black floor glides to the parts shown.

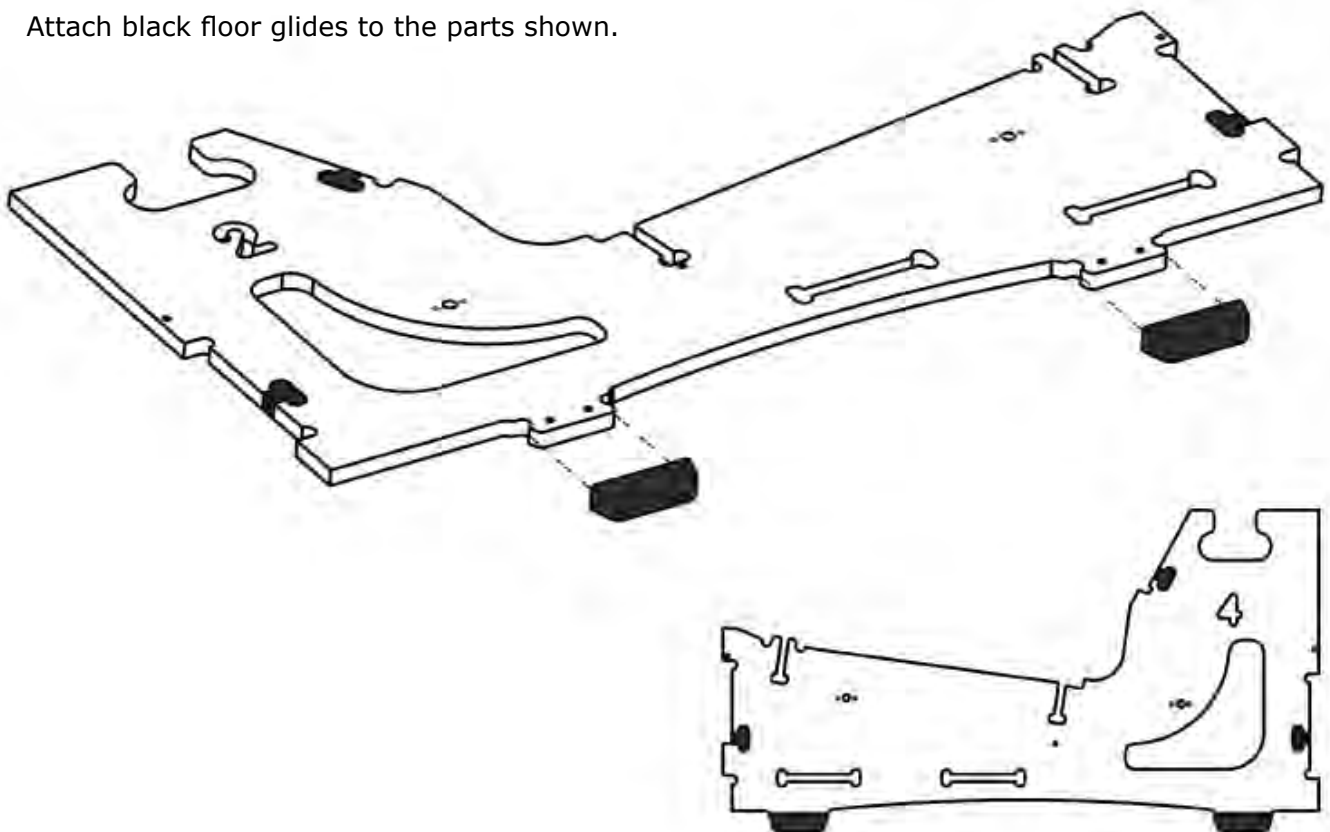

3 Connect parts 1 and 2 together. Repeat for parts 3 and 4.

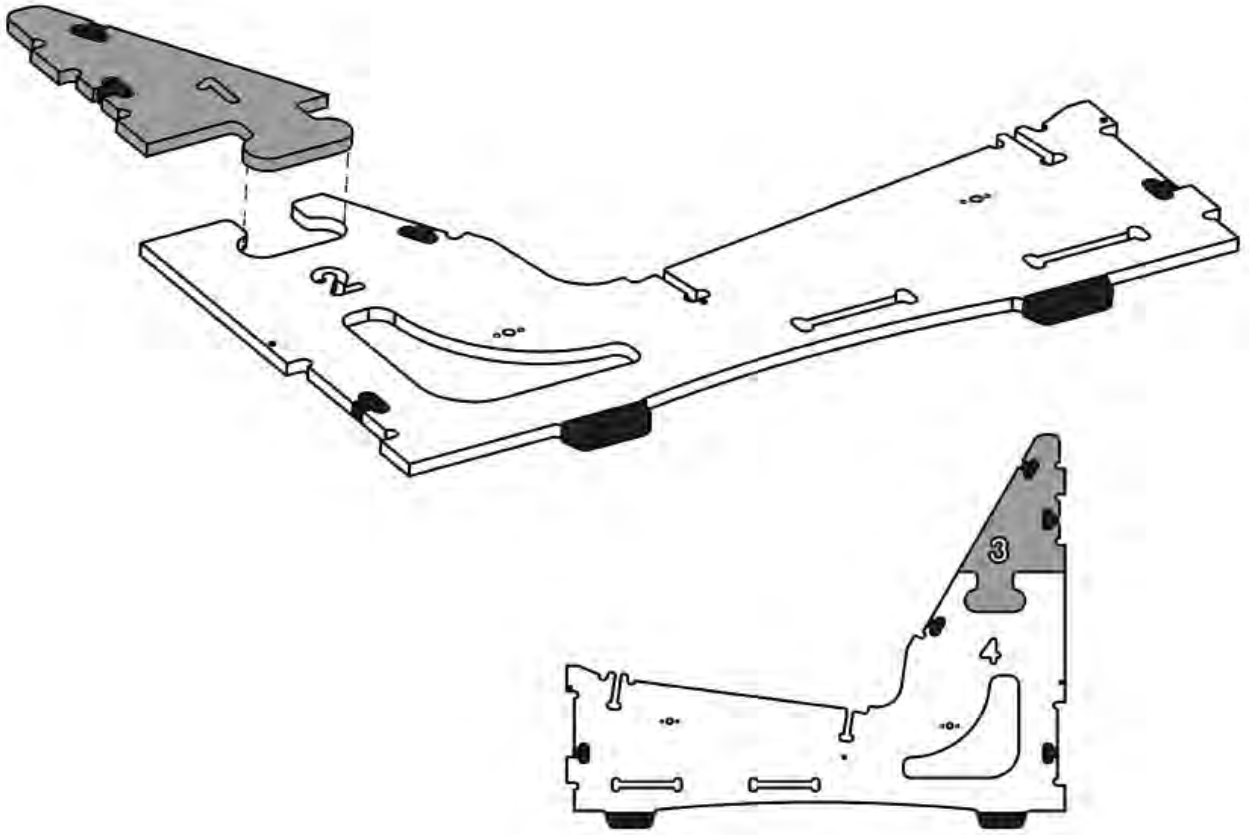

4 Slide part 5 onto part 2 and secure with two screws.

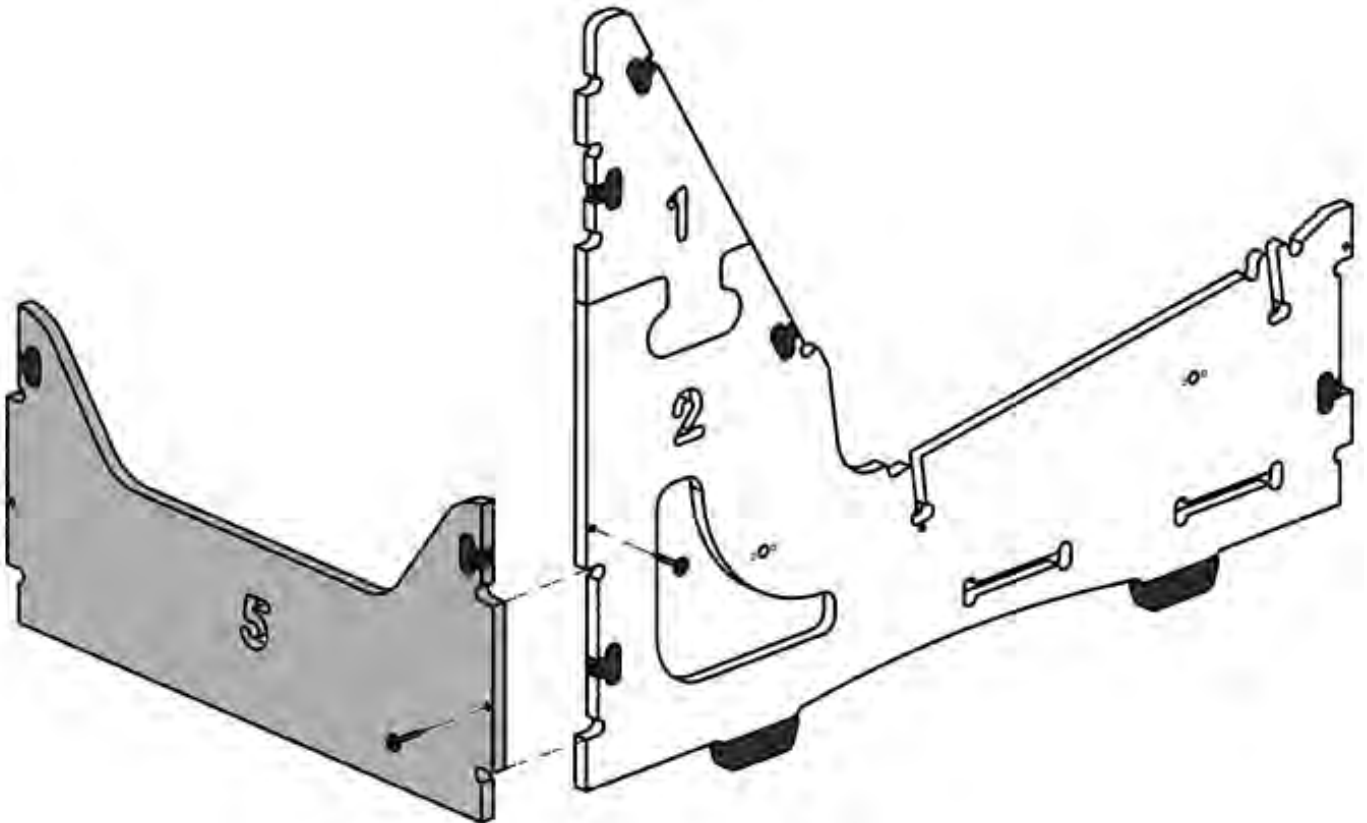

5

Slide part 4 onto part 5 and secure with two screws.

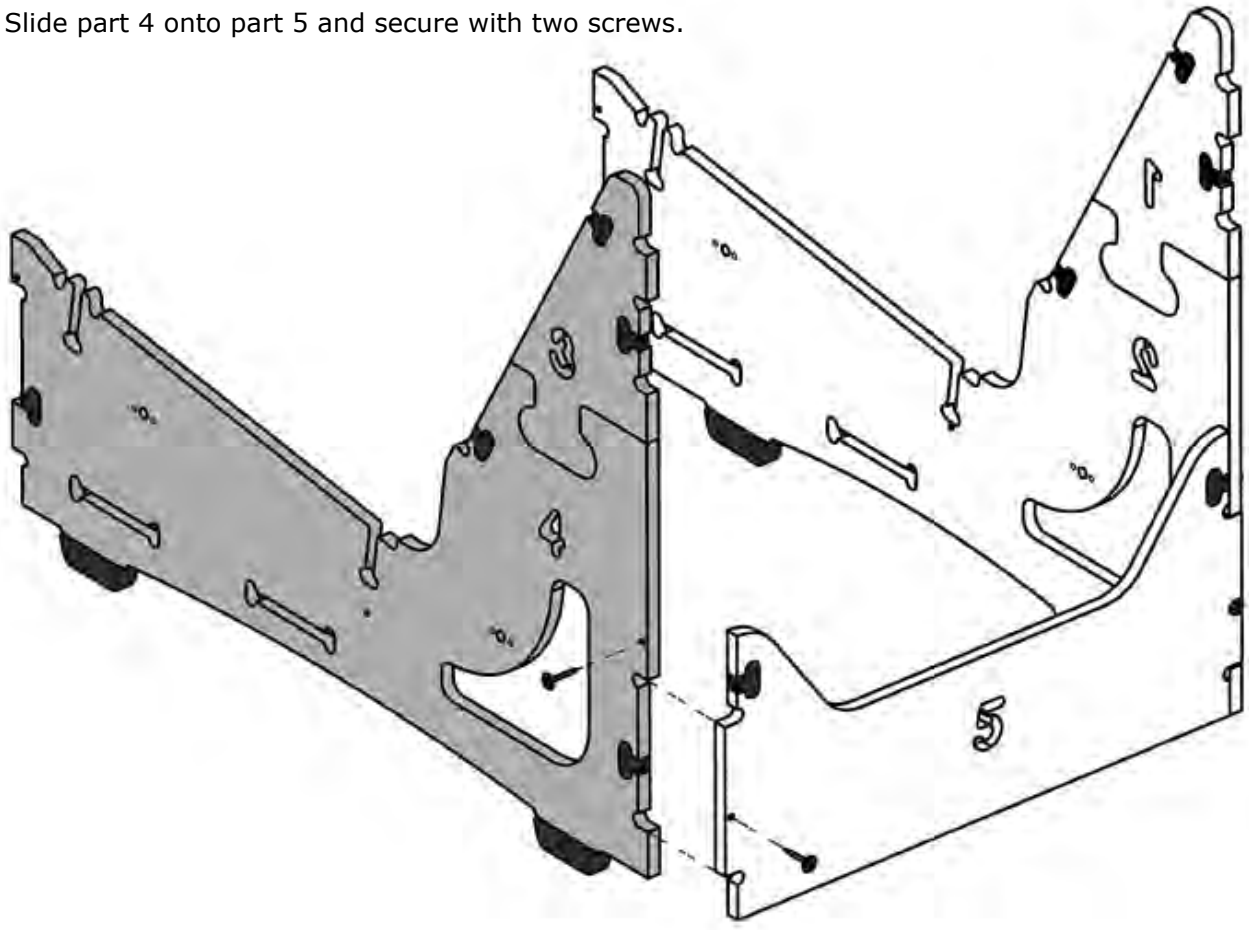

6

Spread parts 2 and 4 apart enough to slide part 6 into the slots on 2 and 4.

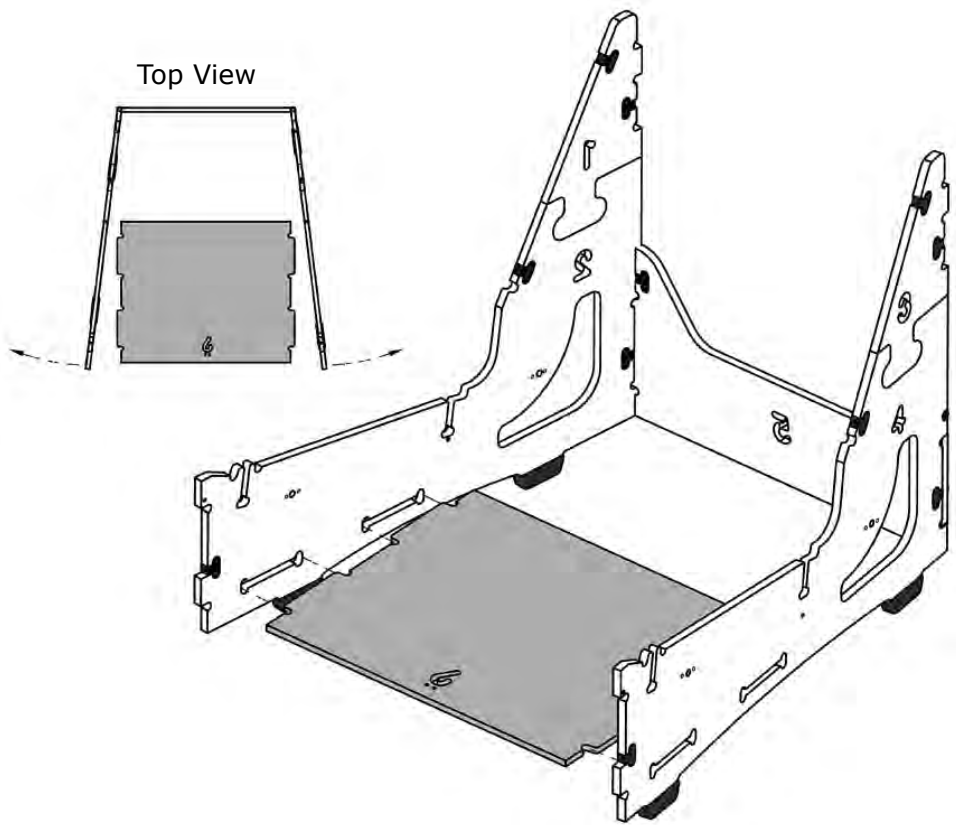

- 7** Slide part 7 onto parts 2 and 4. Secure with four screws.

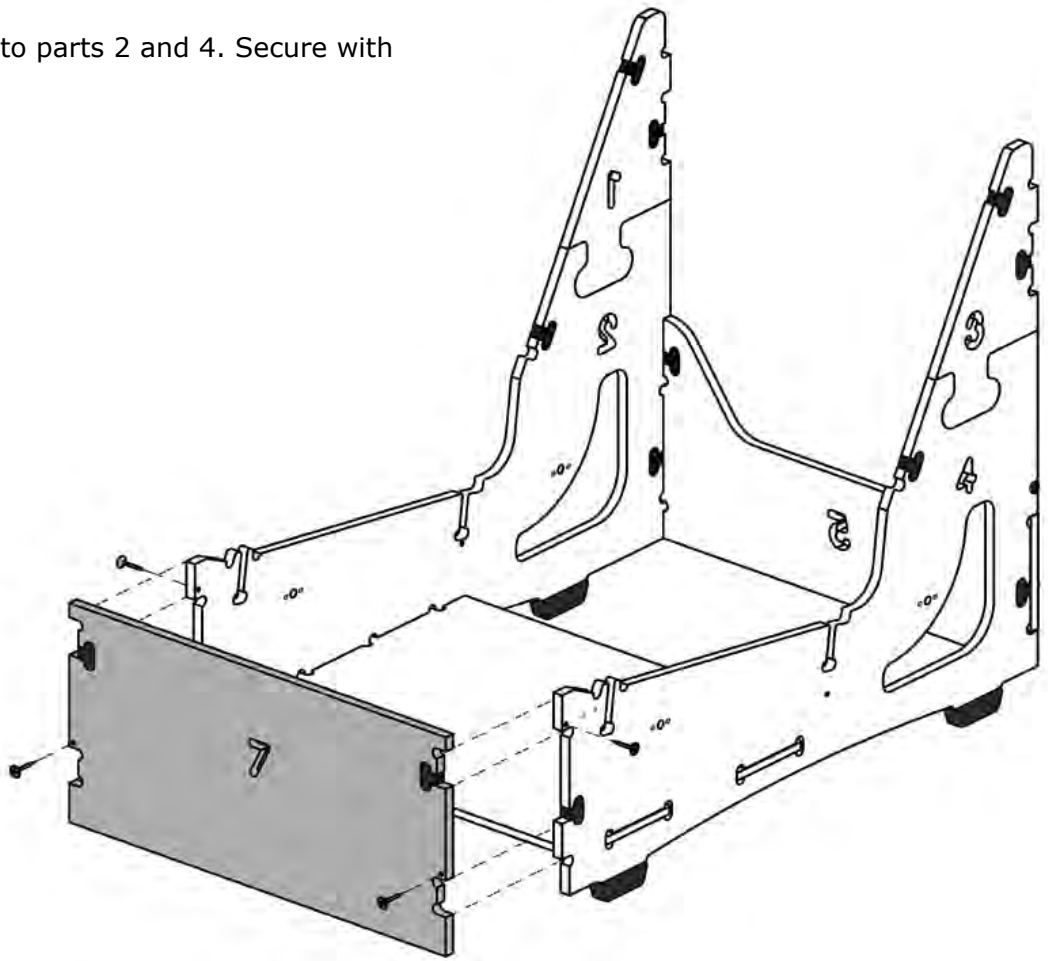

- 8** Place part 8 onto parts 1, 2, 3, and 4, then secure with four screws.

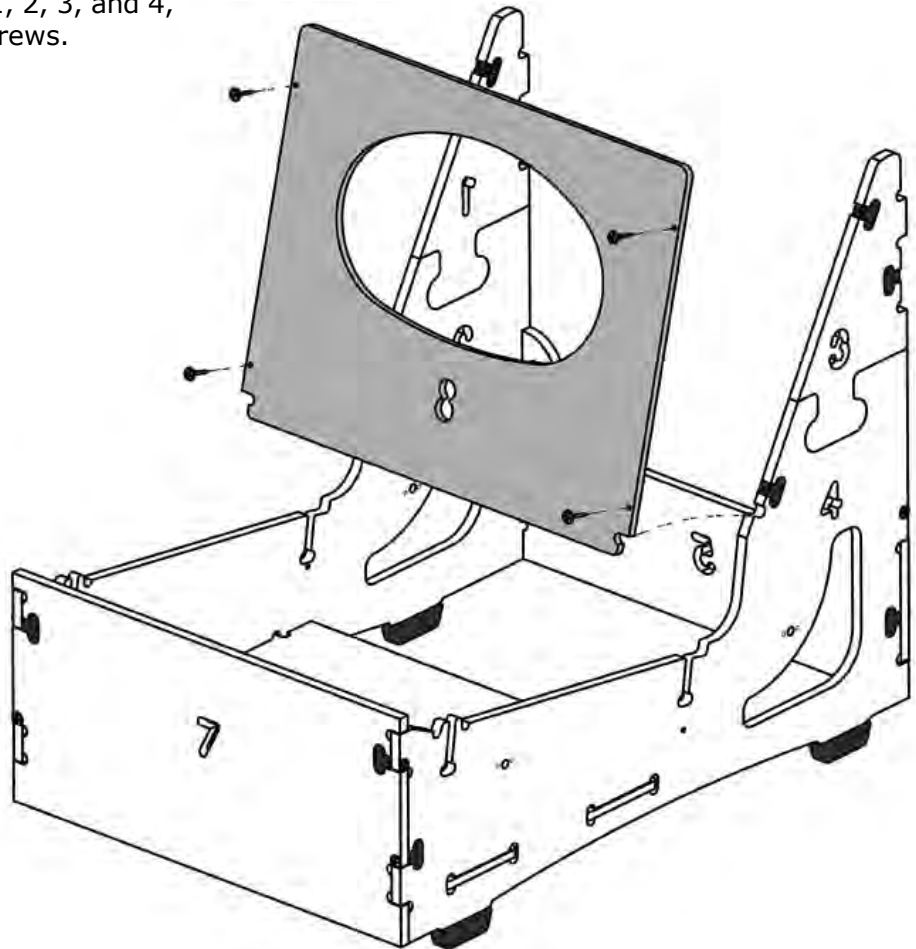

- 9** Place part 9 onto parts 1 and 3 and secure with two screws.

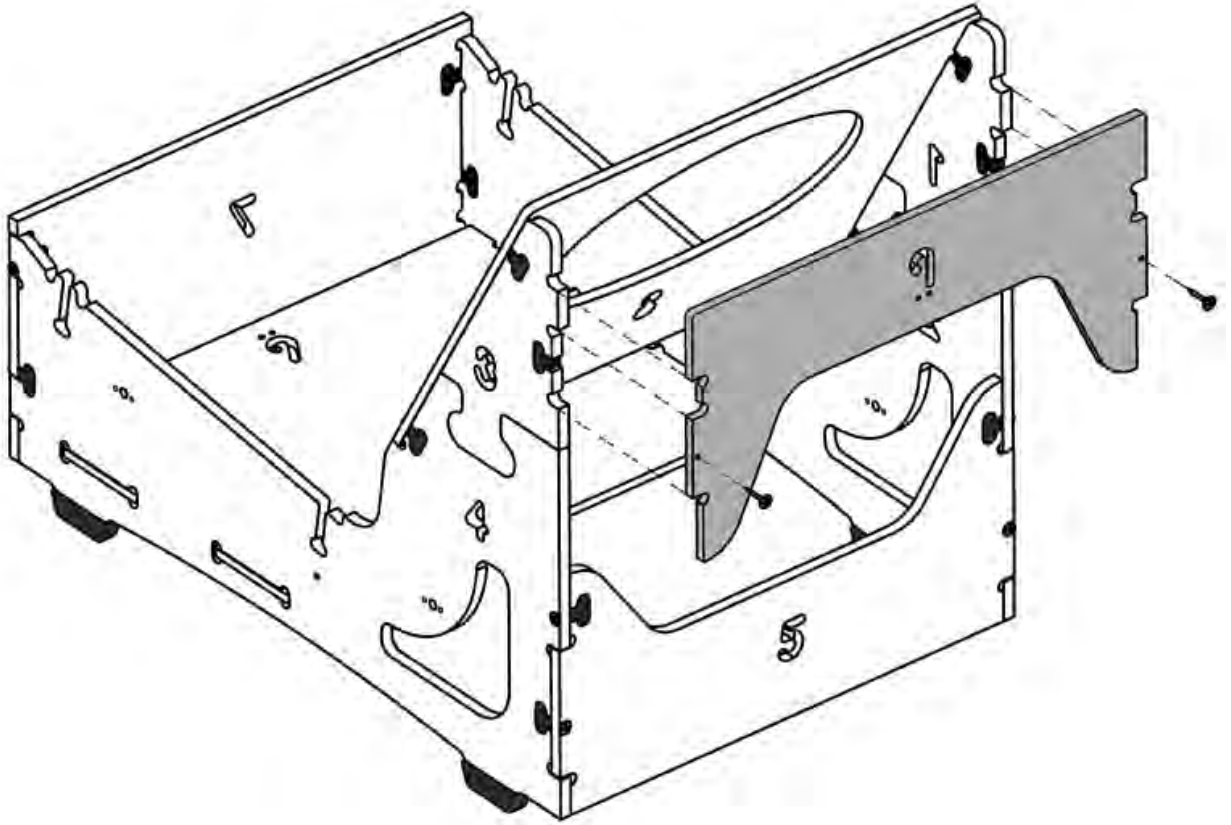

- 10** Slide part 10 into the back slots located on parts 2 and 4 and secure with two screws.

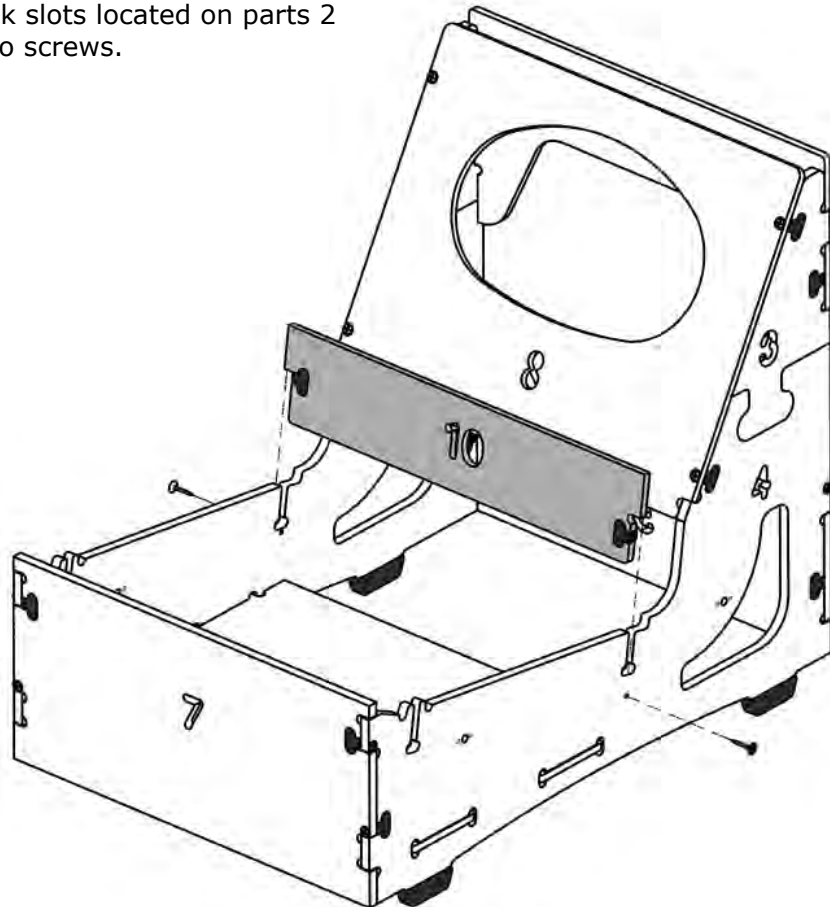

11

Slide part 11 into the slots located on parts 2 and 4.

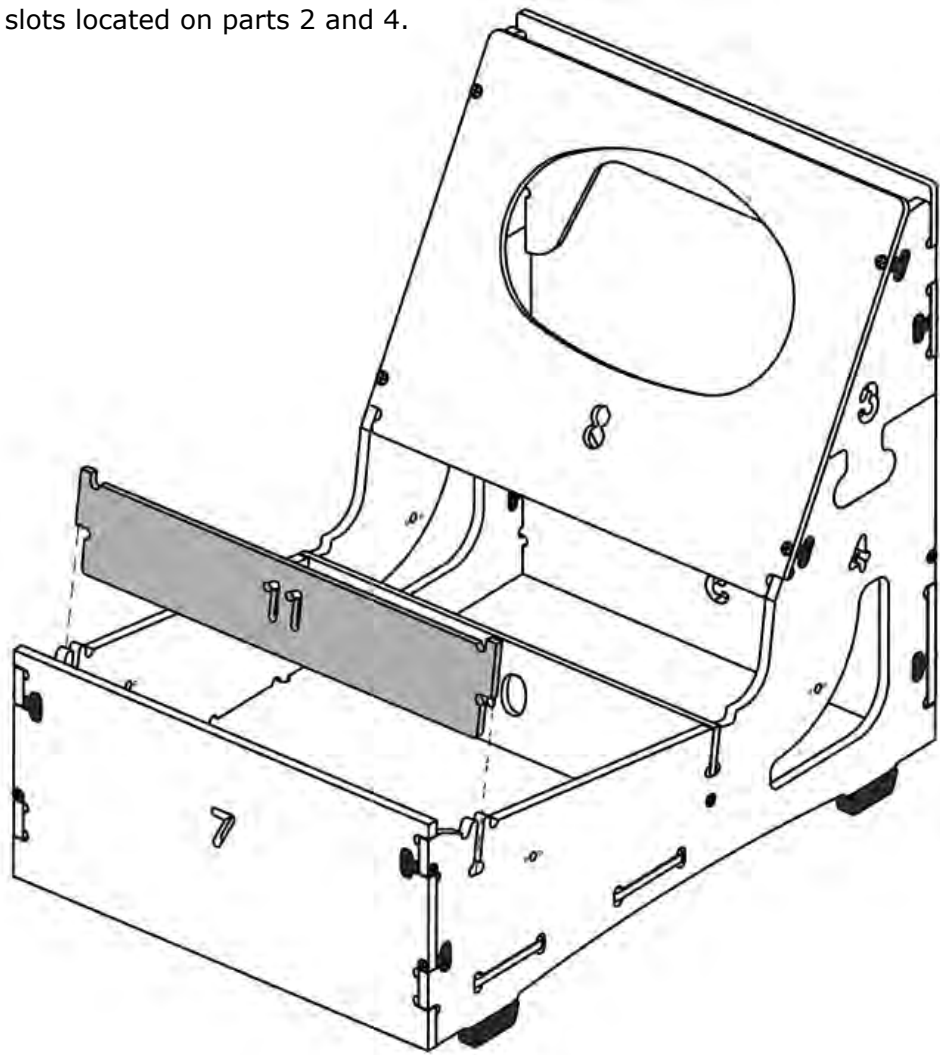

Frame assembly complete. You will have wood pieces 12 and 13 remaining, as well as two wood end panel pieces. These will be used later during fabric and foam assembly.

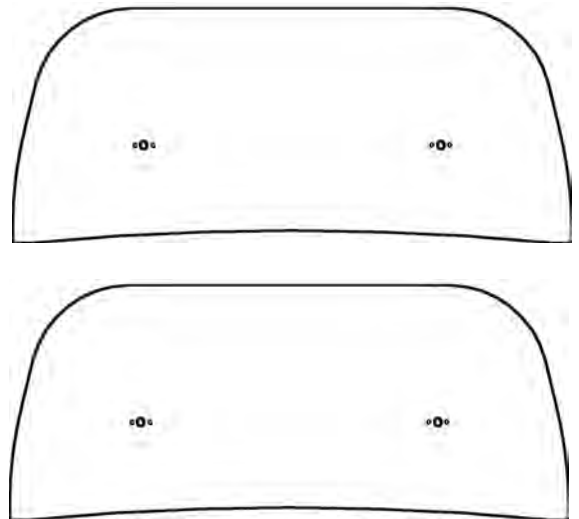
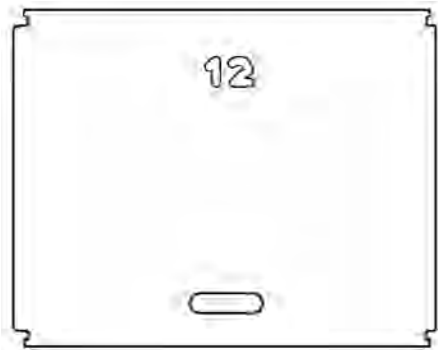

Fabric & Foam Assembly

Most of the fabric covers come inside out (it is the way they are sewn and protects the fabric surface in shipping). Unfold them all in preparation for assembly. To unfold a piece with a zipper, just pull the zipper apart as shown on the right.

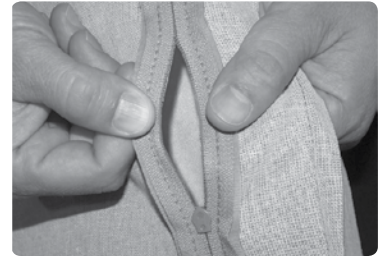

You can snip off any hanging threads from the covers. They are left long during automatic trimming in the sewing process. Snipping them won't affect the strength of the seams.

Beauty tips: In addition to these printed instructions, you may want to watch our beauty tips videos on the customer service page of the website. The videos show demonstrations on how to apply the fabric covers and make them smooth and wrinkle free.

Fabrics



End Panel Cover (2)



Seat Cushion Cover (1)



Back Cushion Cover (1)



Elite Fabric (1)



Frame Back Cover (1)



Frame Front Cover (1)

Foam



Seat Cushion (1)



Top Rail (1)



Back Cushion (1)

1

Take the Top Rail and place it on the top of the frame. Push it down into position between the front and back wood pieces.

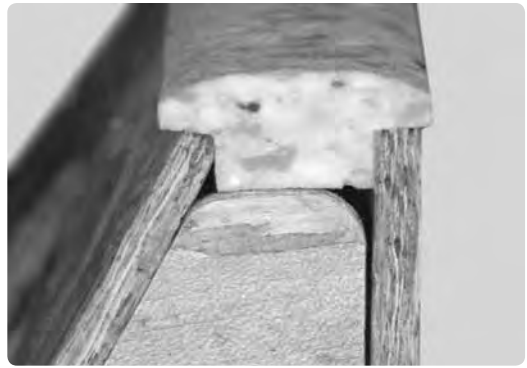

2



Take the Frame Front Cover as shown above.



Insert wood piece 13 all the way into the sleeve sewn into the cover.



Hold the wood firmly in place...



... and wrap the cover around the end of the wood...



... as you tuck the wood into the cover..



... on both ends.

3



Place the cover on the front of the frame...



...to form the front edge.



The wood piece will fit onto the frame as shown.



Put the top corners of the cover in position...



... and then pull the bottom corners of the cover around the bottom of the wood frame as shown.



Repeat the process for the other side of the frame.

4



Take the Frame Back Cover and place it over the back of the frame.



Pull the cover down, aligning the cover seams with the edge of the frame.



Wrap the cover around and under the back corner of the frame.



Repeat the process for the other side of the frame.

5



Place the End Panel Covers over the wood end panels.



Arrange the cover so that the end panel is fully covered. It can be helpful to hold the cover as shown in the photo and shake the wood part down into position.

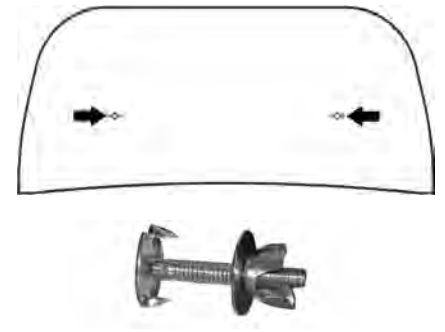

There are two holes in the wood which are now covered. It is through these holes you'll be placing the connector bolts in the following steps.

6



Reach inside the End Panel Cover and insert the connector bolts into the holes.



The two prongs on the connector bolt go into the two small holes. This keeps the bolt from turning.

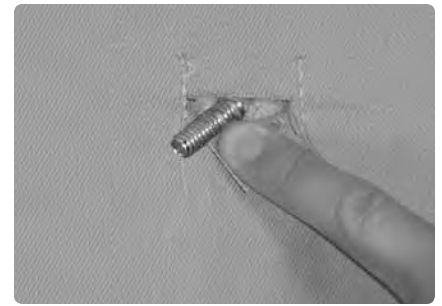

The connector bolt protrudes through the hole cut in the fabric.

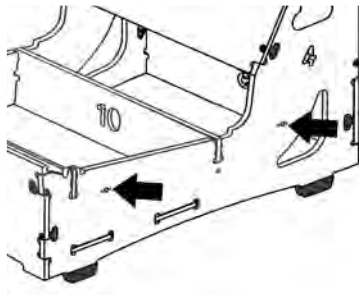

Notice the two holes in the frame through which you will be placing the connector bolts.



With the end panel pushed against the frame, insert the connector bolt through the frame as shown.



Take the washer and wingnut and get them started onto the bolt. Don't tighten completely.



Follow the steps above at the front and back of the panel.



Now, tighten the wingnuts. Repeat on the opposite side of the frame with the second end panel.

7



Now take wood part 12 and place it into position as shown.

8

Find the Seat Cushion Cover and Seat Cushion Foam and follow the sequence below.



Match the rounded front edge of the Seat Cushion Foam with the rounded edge of the Seat Cushion Cover.



Position the cover over the foam and align the corners of the foam cushion with the corner seams of the cushion cover.



You can stick your hand inside to get everything smooth.



Working your way around the sides of the cushion, pull the corners of the cover onto the foam...



... and zip up the cover.



Place the seat cushion on the frame. The rounded edge of the cushion goes toward the front.

9

Cover the Back Cushion with the Elite Fabric. The elite is a white silky material that helps you slide the cover over the foam in step 11. Without the elite, the fabric cover sticks to the foam and is difficult to get into position.



Start by laying the elite over the wedge-shaped area of the Back Cushion.



Leave enough overlap...



... so that you can wrap it up under the wedge.



Now, bring it over the top of the foam.



Stretch it out wide...



... and lay it down the front of the foam.



Position the elite across the bottom...



... and then bring it back up the foam so that you finish under the wedge-shaped area.



Smooth the sides and make sure all the foam is covered.

10



Take the Back Cushion Cover and place it over the side of the elite covered back cushion foam. Start at the top corner.



Insert the wedge-shaped area into the top of the cover. You can work the materials with your hands and also reach up under the cover to smooth and straighten.



Turn the cushion over. Smash down the foam, and as you release it, guide the foam...



... so that it pops back up into the wedge-shaped area in the top of the cover. Straighten as necessary.



Work the cover down along the sides.



Wrap the cover around the corners of the foam...



... and start zipping the cover closed.



Zip the bottom...



... and up the other side.



Once the zipper is closed, you can work the cover by hand to make it all fit evenly. Wide sweeping motions work better than small movements.



Make sure the cover is pressed all the way up into the wedge area.



The back cushion is now ready to be placed on the frame.

11



Place the back cushion on the frame.



Congratulations, assembly is now complete.



SEAT DEPTH ADJUSTMENT

The furniture is designed to allow for seat depth adjustments. The normal setting for the cushions to protrude is 1½" out in front of the frame. Slide the seat cushion in or out to adjust to your own seat depth preference.



REMEMBER

You can snip off any hanging threads from the covers. They are left long during automatic trimming in the sewing process. Snipping them won't affect the strength of the seams.

Blank

HOME | RESERVE

Home Reserve products are
made in the USA under patents:

#6,267,446

#6,568,058

#6,981,747

#7,044,557

#7,523,989

