



Sectional armless

assembly instructions





Smooth & Wrinkle-Free Fabric Covers:

In addition to these printed instructions, you may want to watch our beauty tips videos on the customer service page of our website. The videos show demonstrations on how to apply the fabric covers and make them smooth and wrinkle free.



Renewability: Individual foam and fabric parts are available. You no longer have to worry that something will happen and you'll just have to live with it. From pet attacks to paint spills, it's easy to recover from a furniture accident.

CUSHIONS

Foam: The seat cushions will feel firm at first. That's intentional, since firmer foam lasts longer. You can shorten the break-in period by putting the cushions on the floor and walking on them for a few minutes.



Fabric Exchange: To use our 30-day fabric cover exchange program, contact us and we'll lead you through the process. Keep the covers out of actual use to preserve them in new, unused, and clean condition. Fold them neatly when repackaging to avoid wrinkles.

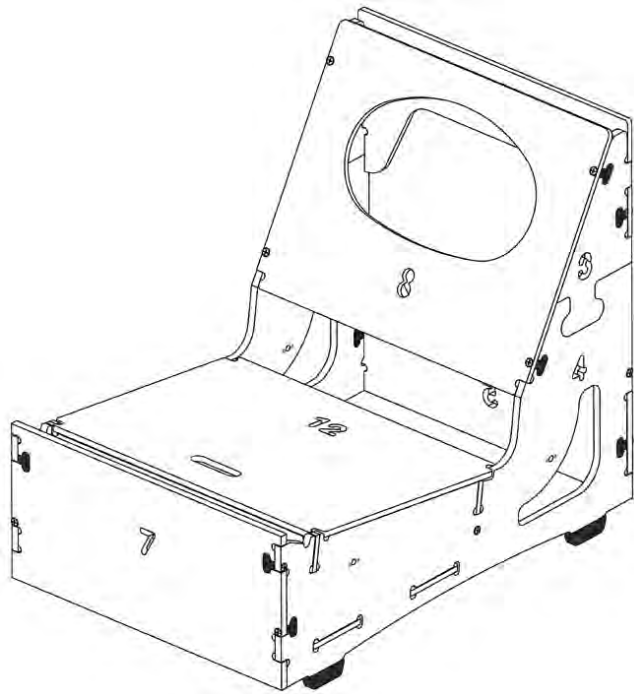

Tools needed: Phillips Screwdriver or powered drill with a Phillips screwdriver bit.

A sanding pad is included in case you wish to smooth over any of the surfaces or edges after the frame is assembled. It is not necessary to sand any of the frame parts during assembly. No glue will be used during assembly. Item will be ready for use immediately.

Frame Assembly

Open the box and set aside the foam and fabrics for later. Then take the wood parts out of the box. The parts are not packed in the order of assembly so don't worry about getting them mixed up. They are all numbered for easy reference.

- 1** Open the parts bag and insert the black plastic T connectors into the parts shown here. Through-out these instructions it is okay to use a hammer to tap the T-connectors and wood parts into position.

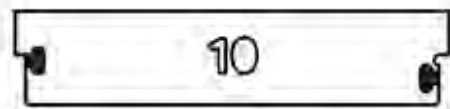
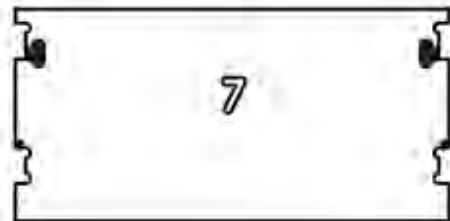
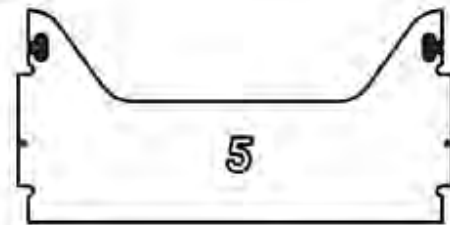
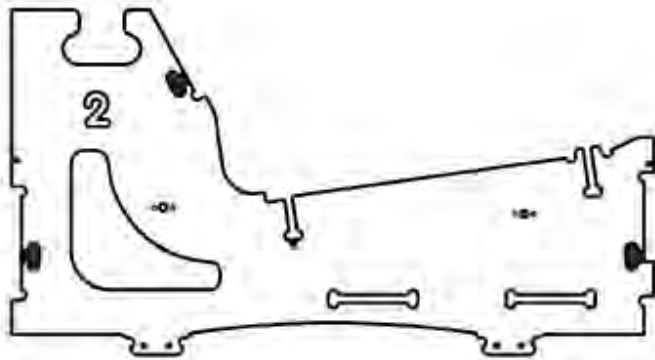
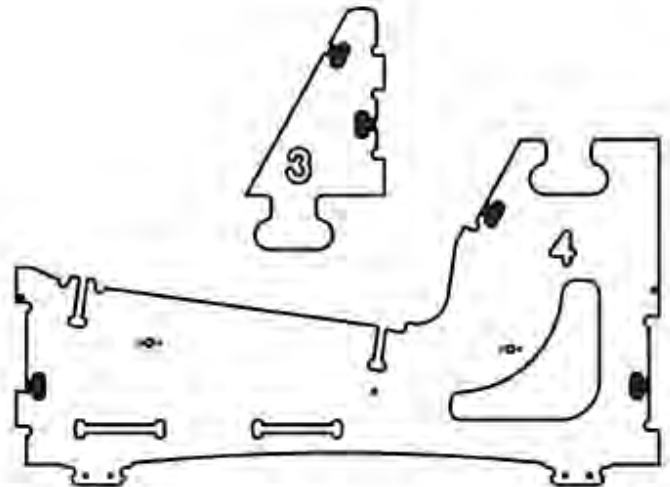
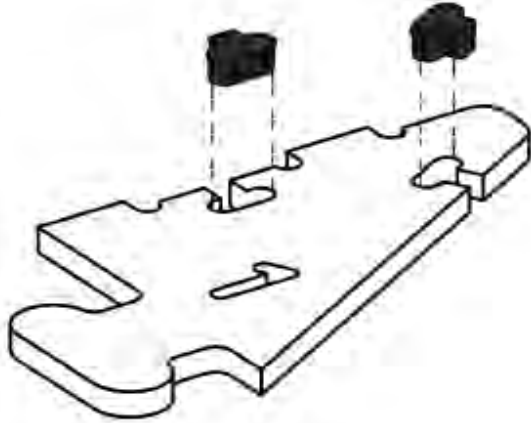

2

Attach black floor glides to the parts shown.

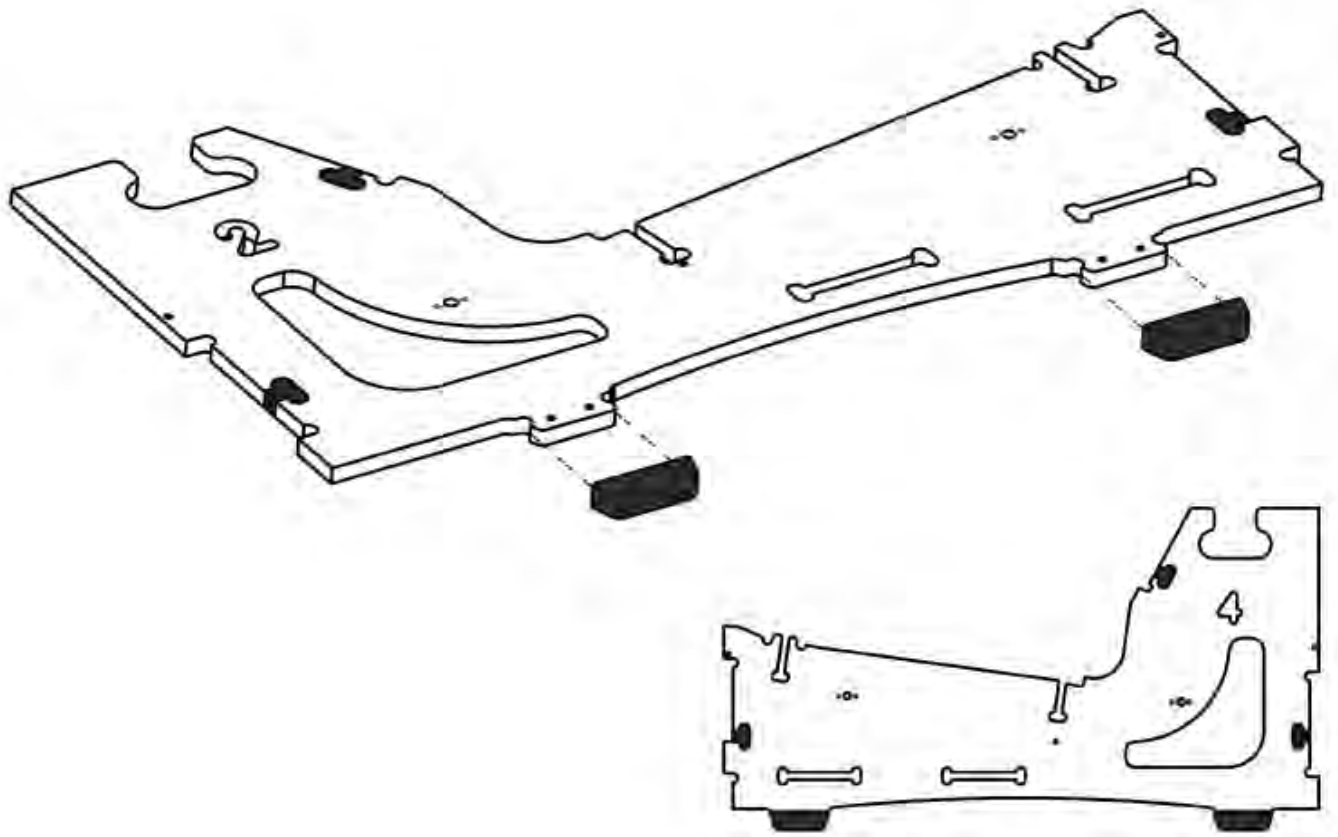

3

Connect parts 1 and 2 together. Repeat for parts 3 and 4.

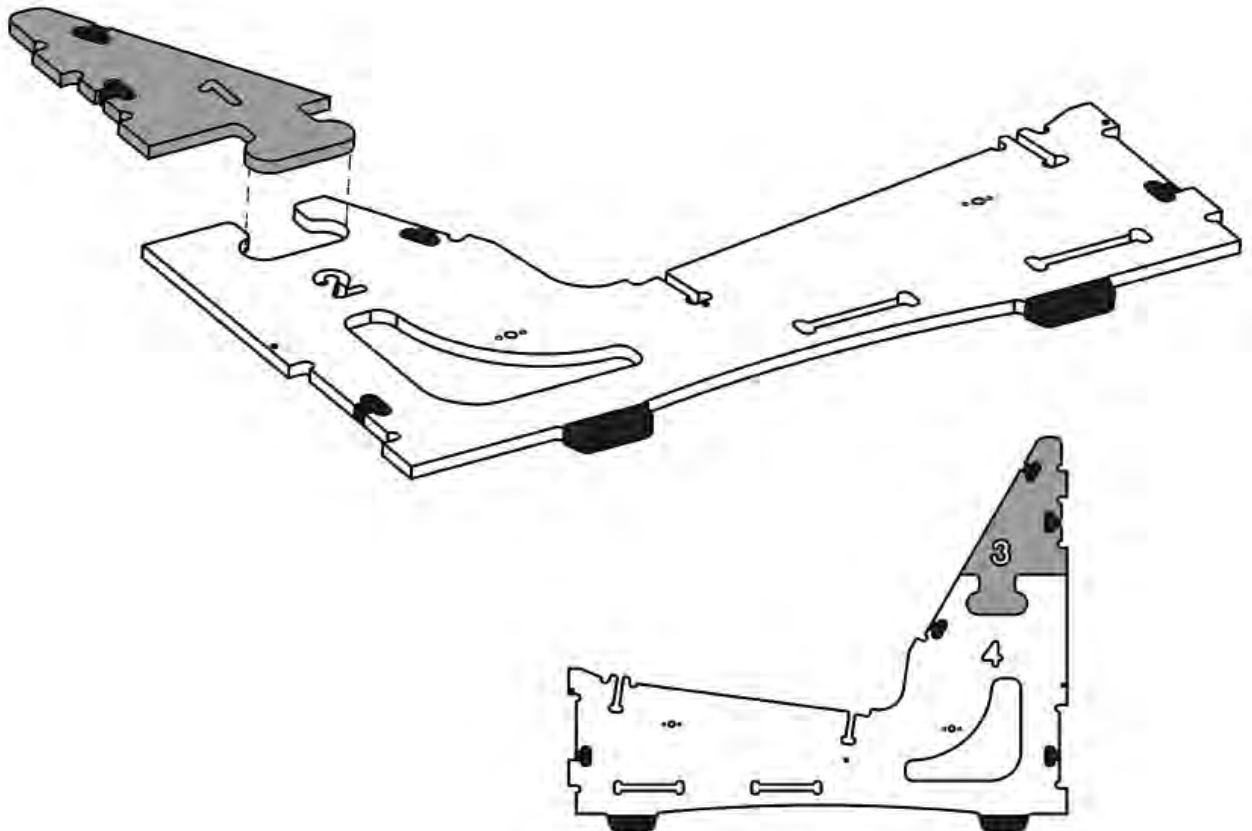

4 Slide part 5 onto part 2 and secure with two screws.

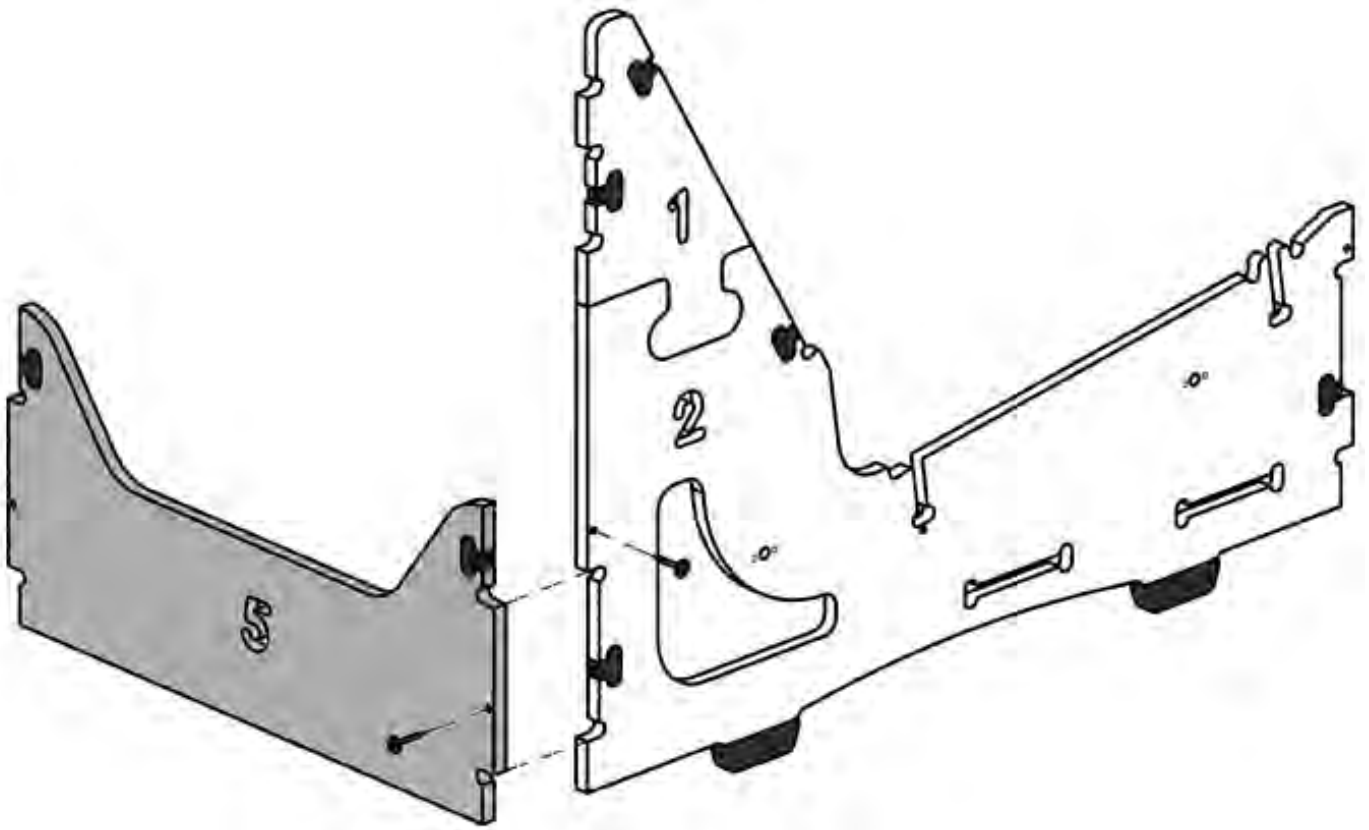

5 Slide part 4 onto part 5 and secure with two screws.

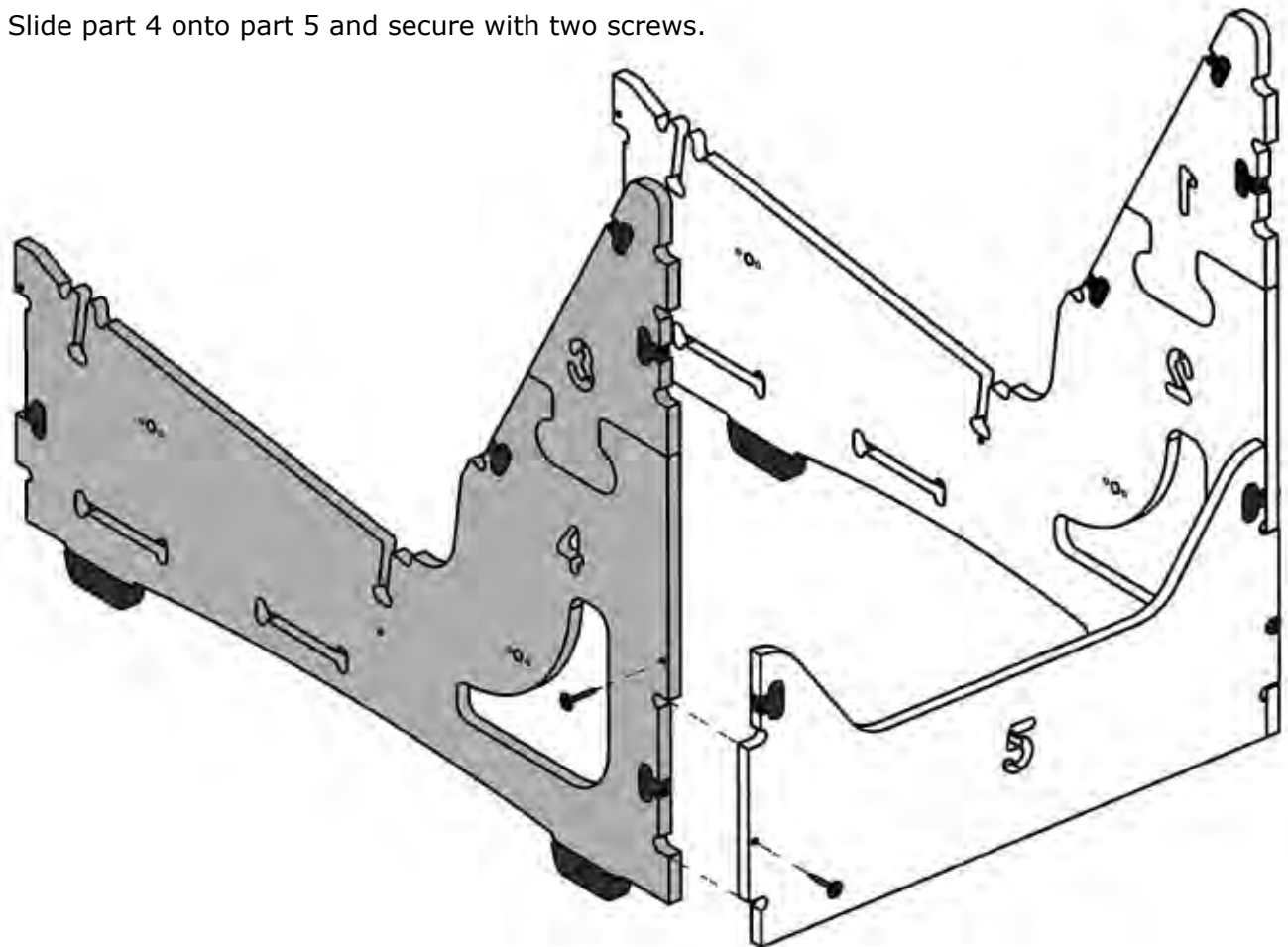

6

Spread parts 2 and 4 apart far enough to slide part 6 into the slots on 2 and 4.

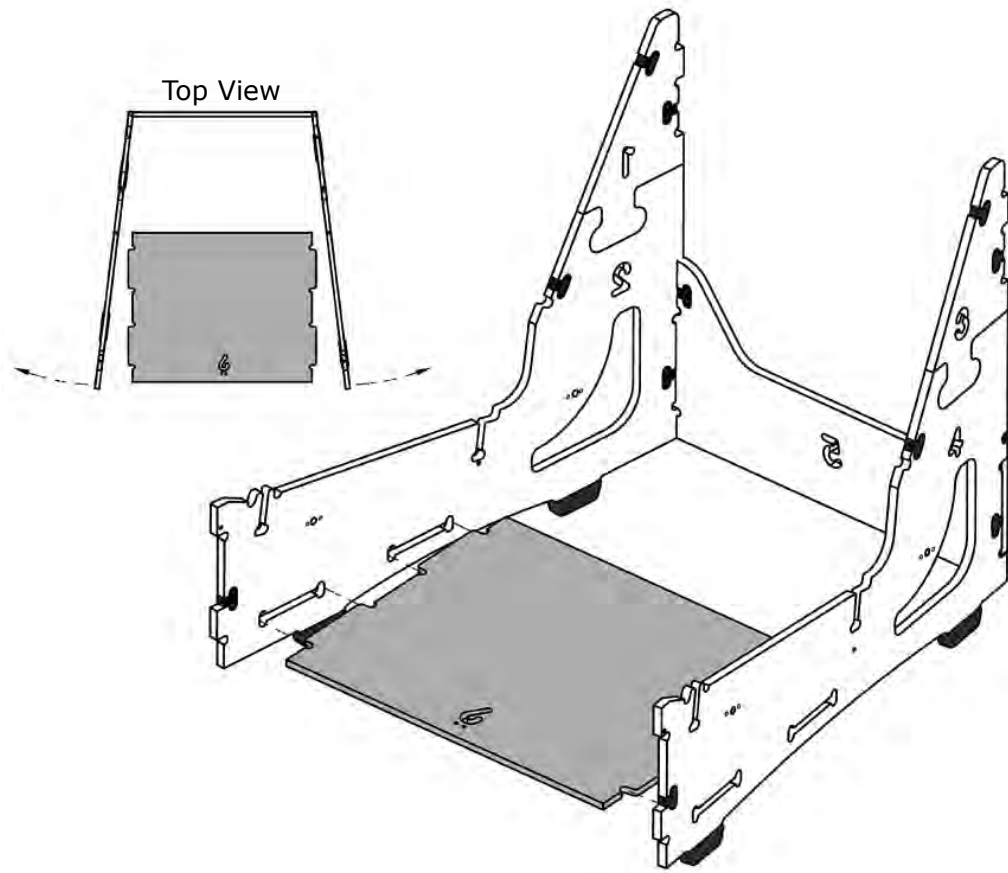

7

Slide part 7 onto parts 2 and 4. Secure with four screws.

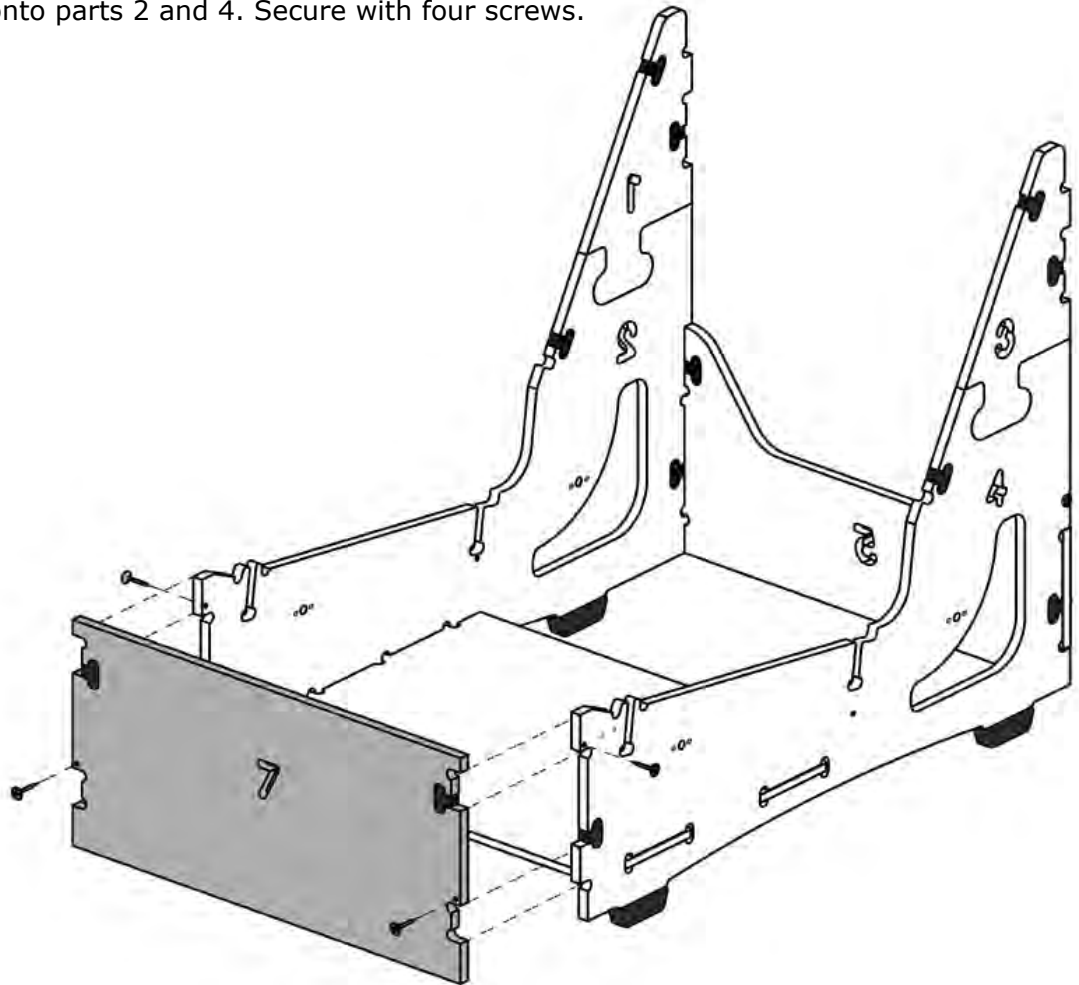

8

Place part 8 onto parts 1 and 2 and parts 3 and 4 and secure with four screws.

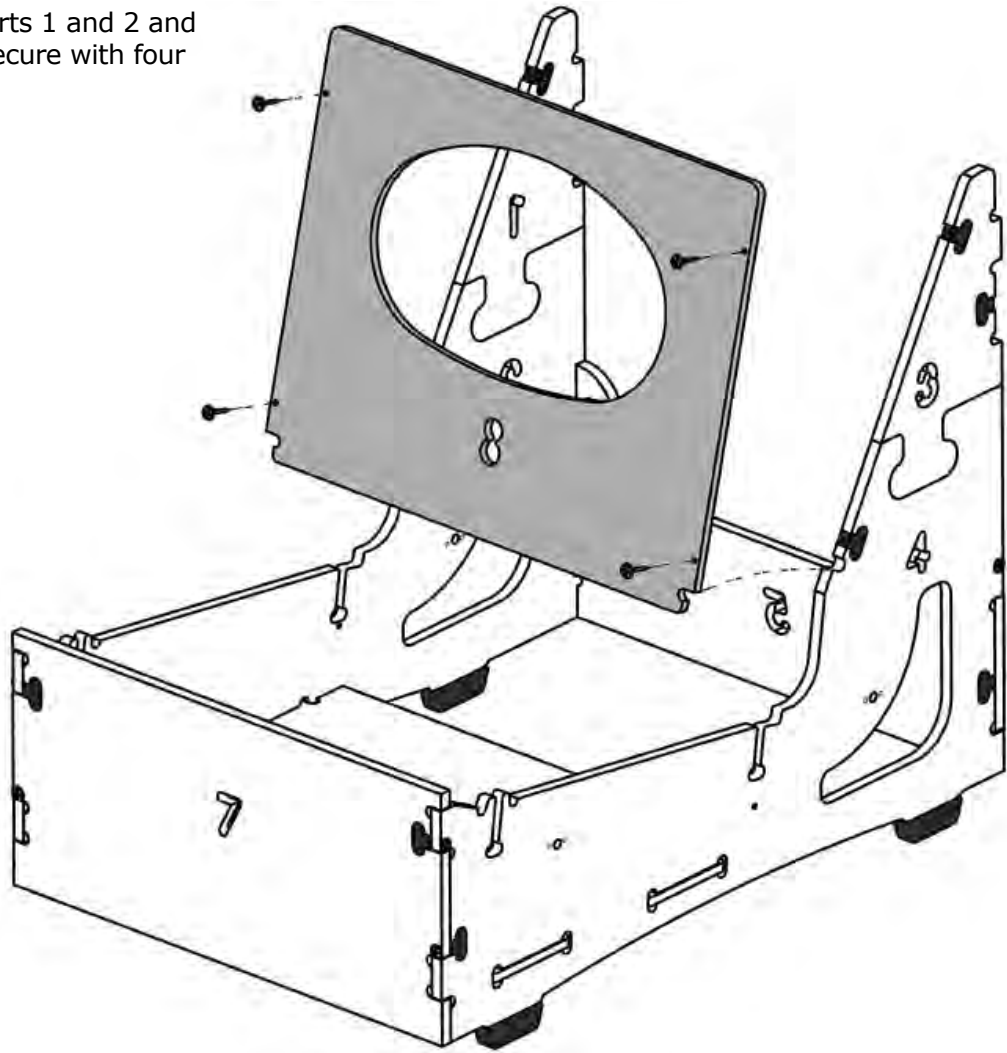

9

Place part 9 onto parts 1 and 3 and secure with two screws.

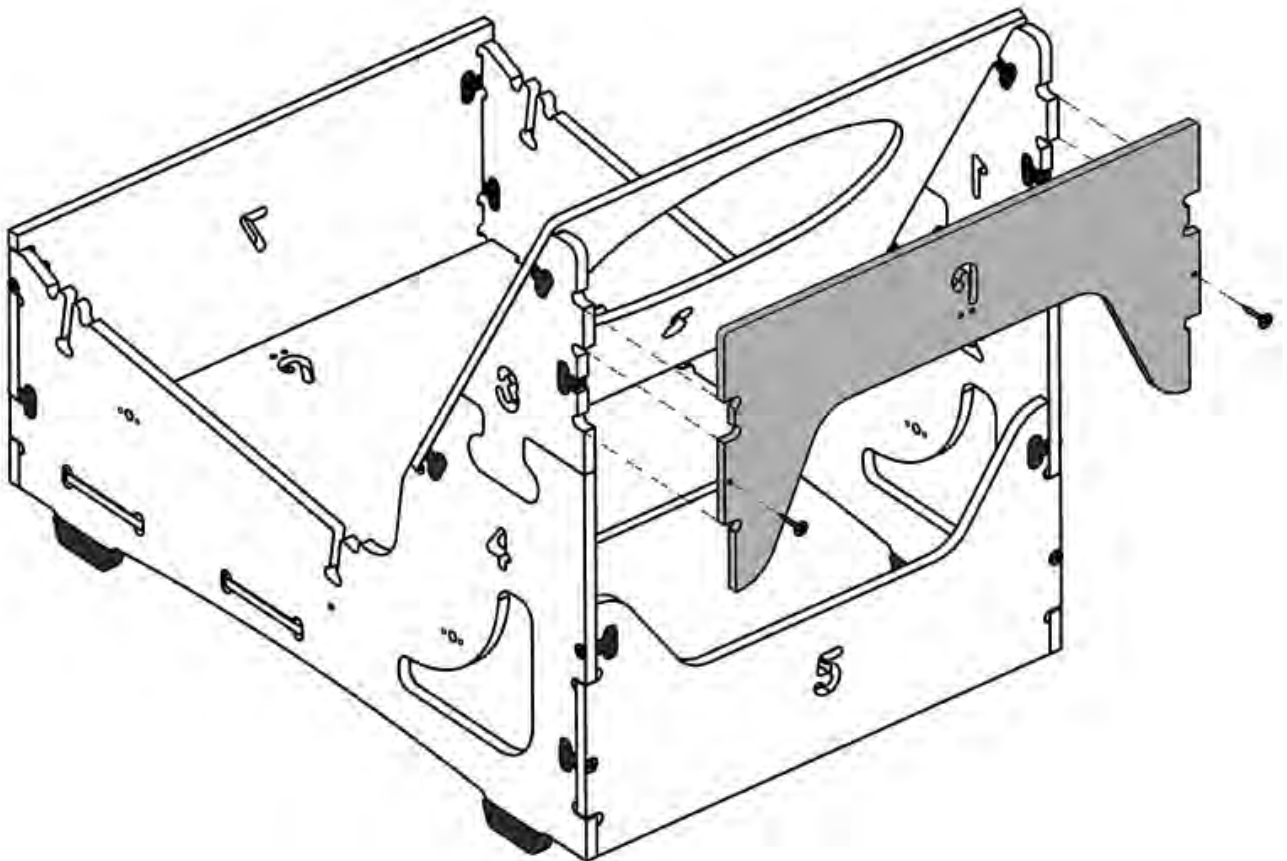

- 10** Slide part 10 into the rear slots located on parts 2 and 4 and secure with two screws.

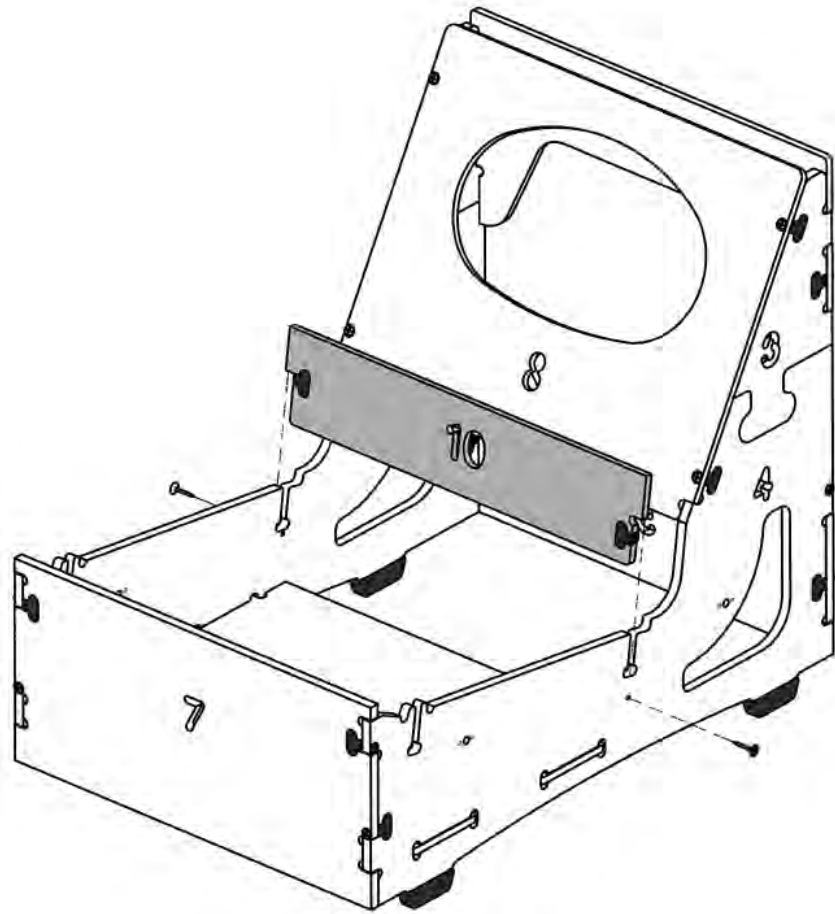

- 11** Slide part 11 into the front slots located on parts 2 and 4.

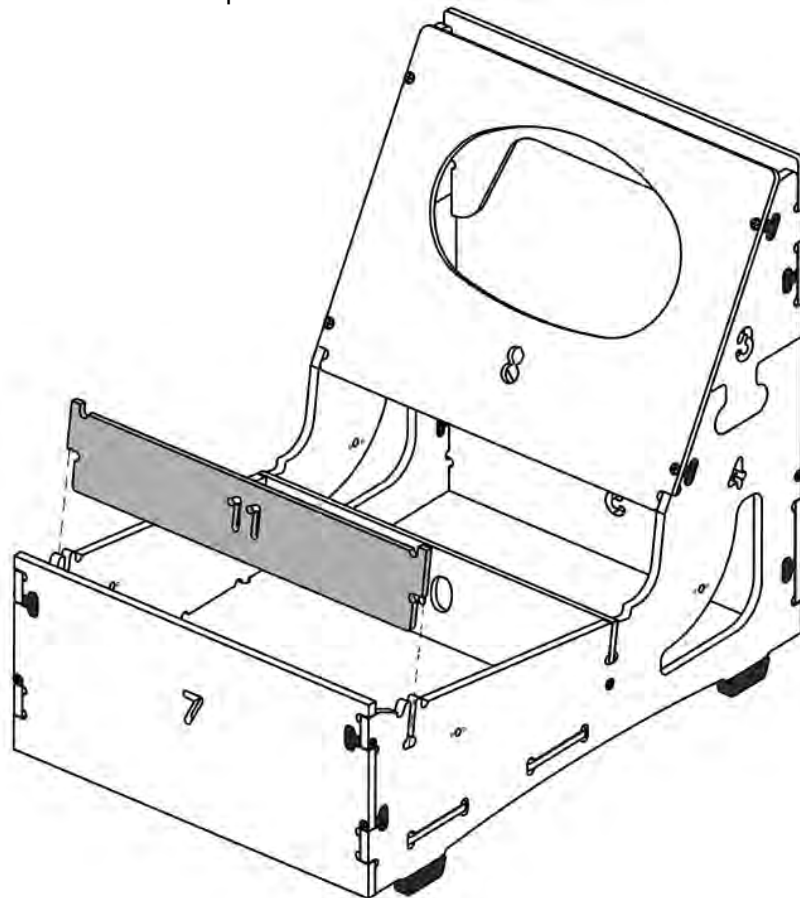

12

Place part 12 on the top of parts 2 and 4.

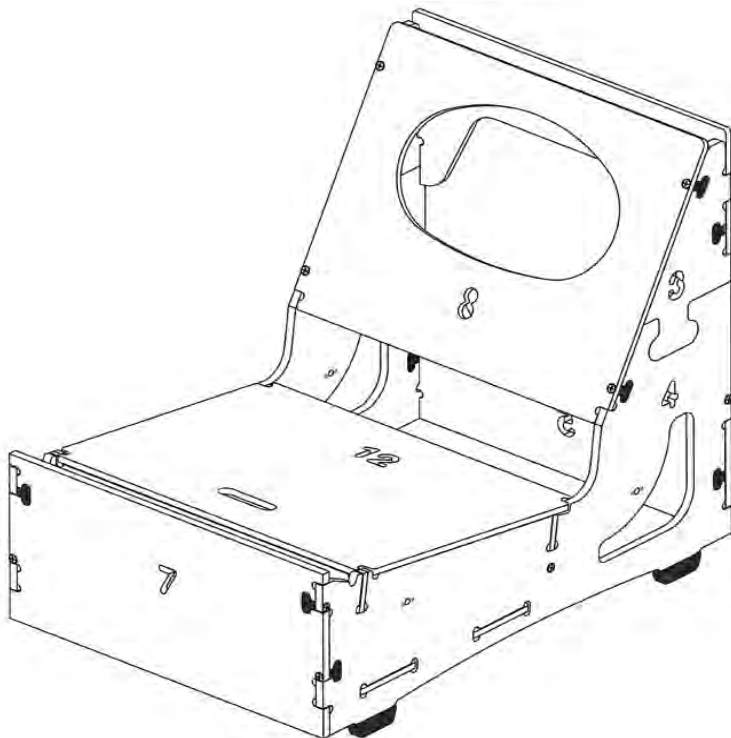
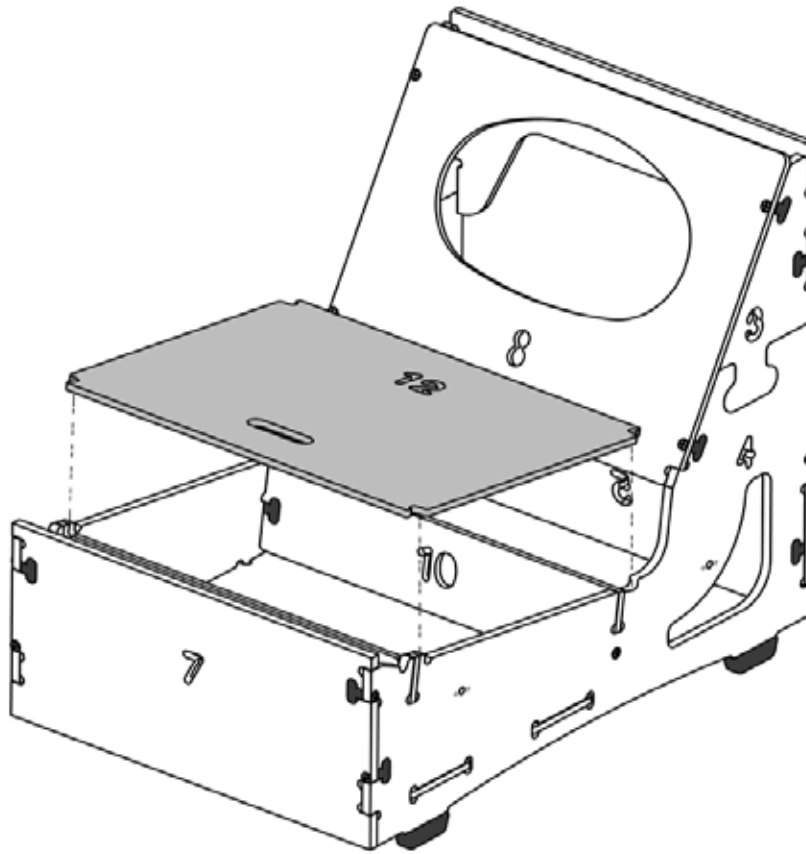

Frame assembly is now complete. You will have one piece of wood left, part 13. It will be used a little later during fabric assembly.

Fabric & Foam Assembly

Most of the fabric covers come inside out. (It is the way they are sewn and protects the fabric surface in shipping.) Unfold them all in preparation for assembly. To unfold a piece with a zipper just pull the zipper apart as shown in the picture to the right.



You can snip off any loose hanging threads from any of the covers. They are left long during automatic trimming in the sewing process. Snipping them won't affect the strength of the seams.

Beauty tips: In addition to these printed instructions you may want to watch our beauty tips videos on the customer service page of the website. The videos show demonstrations on how to apply the fabric covers and make them look smooth and wrinkle free.

Fabrics



Seat Cushion Cover (1)



Back Cushion Cover (1)



Frame Bck Cover (1)



Frame Front Cover (1)

Foam



Seat Cushion (1)



Top Rail (1)



Back Cushion (1)

- 1** Take the Top Rail Foam and place it on the top of the frame. Push it down into position between the front and back wood pieces.

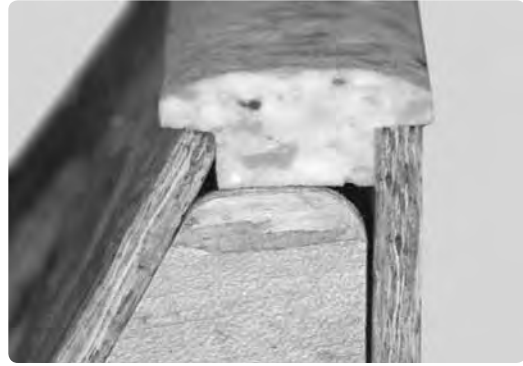

- 2** Locate wood piece number 13. Take the Frame Front Cover and slide wood piece 13 into the sleeve sewn into the cover. Then place the cover on the front of the frame to form the front edge. Pull the bottom corners of the cover around the bottom of the wood frame as shown.



3

Take the Frame Back Cover (the largest fabric piece) and place it over the back of your frame. The bottom corners fit under the frame as shown.



4

Find the Seat Cushion Cover and Seat Cushion Foam and follow the sequence below.



Match the rounded front edge of the seat cushion foam with the rounded edge of the seat cushion cover.



Position the fabric over the foam and align the corners of the foam cushion with the corner seams of the cushion cover.



You can stick your hand right up in there to get everything smooth.



Working your way around the sides of the cushion pull the corners of the cover onto the foam...



...and zip up the cover.



Place the seat cushion on the frame. The rounded edge of the cushion goes toward the front.

5

Find the Back Cushion Covers and the dacron filled Back Cushions and follow the sequence below.



When filling the back cushion, match up the rounded corners of the back cushion with the rounded corners of the cover.



Push the filler into the cover. You can reach way up in there to fill out the corners.



Zip up the cover.



You can knead the cushion on the floor to straighten and smooth it out.



You can further straighten and smooth the back cushion by striking it on the floor with several good whoops.



Change ends of the cushion and repeat.



This is also the way you can "fluff" the cushions in the future.



Place the back cushions on the frame.



Congratulations, assembly is complete.

Joining Your Sectional Group Together

Once you have all the individual pieces of your sectional group assembled, arrange them in the room according to your design plan. Then, starting at one end of the sectional arrangement, follow these instructions to secure all the units tightly together.

The frames will be joined together with the connector bolts from the parts bags. A cut away showing how these connector bolts will be used is shown to the right of this paragraph.

There are holes for the connector bolts at the front and back of the frames as indicated by the arrows in the diagram below. Remove the storage lids to access these holes. Align the frames and slide the connectors into the holes. Tighten the wingnuts to draw the frames together.

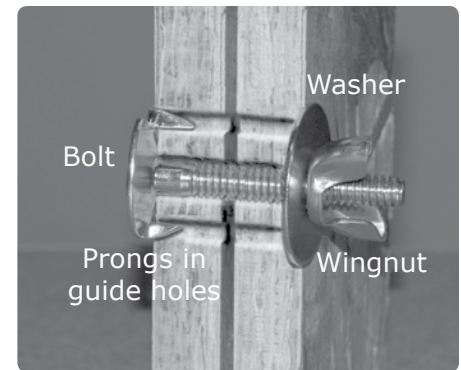

Connector Bolt

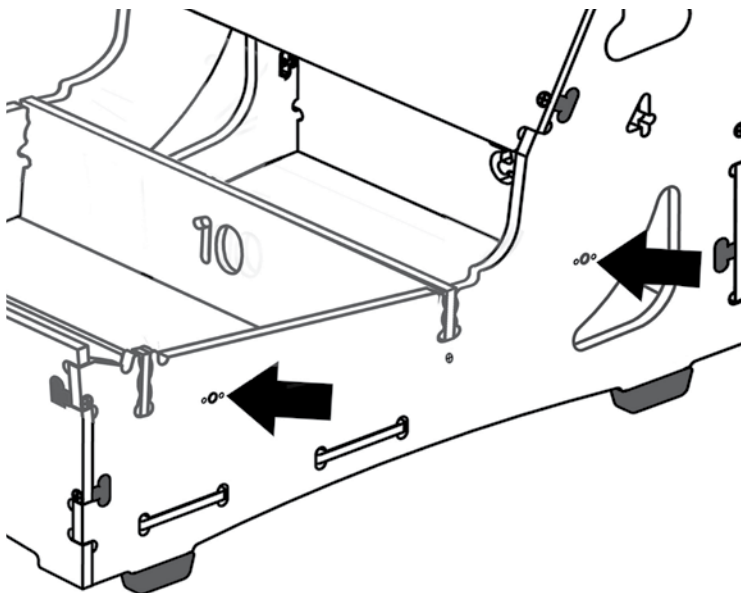

SEAT DEPTH ADJUSTMENT

The furniture is designed to allow for seat depth adjustments. The normal setting for the cushions to protrude is 1½" out in front of the frame. Slide the seat cushion in or out to adjust to your own seat depth preference.



REMEMBER

You can snip off any hanging threads from the covers. They are left long during automatic trimming in the sewing process. Snipping them won't affect the strength of the seams.

HOME | RESERVE

Home Reserve products are
made in the USA under patents:

#6,267,446

#6,568,058

#6,981,747

#7,044,557

#7,523,989

